



Chipsmall Limited consists of a professional team with an average of over 10 year of expertise in the distribution of electronic components. Based in Hongkong, we have already established firm and mutual-benefit business relationships with customers from,Europe,America and south Asia,supplying obsolete and hard-to-find components to meet their specific needs.

With the principle of “Quality Parts,Customers Priority,Honest Operation,and Considerate Service”,our business mainly focus on the distribution of electronic components. Line cards we deal with include Microchip,ALPS,ROHM,Xilinx,Pulse,ON,Everlight and Freescale. Main products comprise IC,Modules,Potentiometer,IC Socket,Relay,Connector.Our parts cover such applications as commercial,industrial, and automotives areas.

We are looking forward to setting up business relationship with you and hope to provide you with the best service and solution. Let us make a better world for our industry!



Contact us

Tel: +86-755-8981 8866 Fax: +86-755-8427 6832

Email & Skype: info@chipsmall.com Web: www.chipsmall.com

Address: A1208, Overseas Decoration Building, #122 Zhenhua RD., Futian, Shenzhen, China



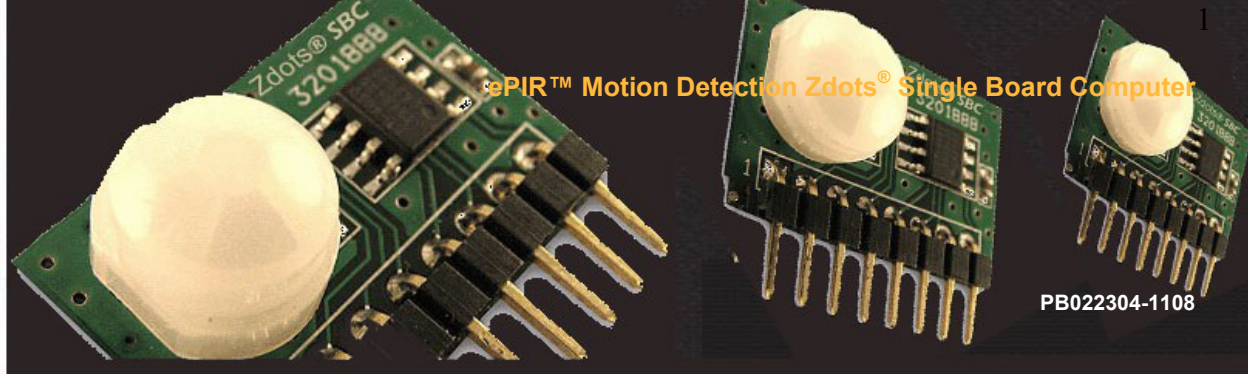

ePIR™ ADVANTAGE

- Complete Motion Detection Solution
- Best in Class Motion Detection Performance
- Extremely flexible interface
- Scalable to meet your application needs

TARGET APPLICATIONS

- Unattended Vending and Kiosks
- Display Systems
- Home Appliances
- Lighting Control
- Access Control
- General Purpose Proximity Sensing Application

ePIR™ Motion Detection Zdots® Single Board Computer

Overview

Zilog's ePIR Motion Detection Zdots Single Board Computer (SBC) is a complete time to market solution for a variety of motion detection applications. ePIR Motion Detection Zdots SBC includes a passive infrared (PIR) sensor and Fresnel lens and provides a significant performance improvement over today's digital solutions. Using PIR sensor technology, it combines the unique features of the Z8 Encore! XP® MCU, including Zilog's Sigma-Delta Technology™, with powerful, new motion detection algorithms, providing a dramatic improvement in both sensitivity and stability.

The ePIR Motion Detection Zdots Single Board Computer is a great time to market embedded solution for any device that needs motion detection capability making it a great choice for lighting controls, access control, display systems and general purpose proximity sensing. It is also an easy way to add energy management capability to various applications such as vending machines and appliances. And with Zilog's development kit, it is quick and easy to customize the application code and add features.

Features

- Complete, fully functional motion detection SBC including low profile Fresnel lens
- Advanced software based motion detection algorithms provide superior sensitivity and stability
- Small form factor – Only 25.5 mm x 16.7 mm
- Wide 5 m x 5 m, 60 degree detection pattern
- Simple hardware or advanced serial (UART) based configuration and interface
- Adjustable sensitivity, delay and ambient light threshold
- SLEEP mode for low power applications
- No temperature compensation required
- Dynamic PIR sensor stabilization minimizes power-on time
- Photocell input for ambient light detection in lighting applications
- Minimal components ensure highest possible Mean Time Between Failure (MTBF)
- Production ready solution or develop your own custom software application
- Complete development system available (ZEPIR000101ZCOG)

APPLICATIONS

Unattended Vending and Kiosks

- Reduce energy consumption by auto-dimming lights when people are not present
- Attract customers when they come near
- Automated guidance

Display Systems

- Reduce energy consumption by turning off when people are not present
- Replace buttons with left/right hand motion
- Attract people when they come near

Home Appliances

- Save energy by turning off large appliances when people are not present
- Air conditioners
- Ventilators
- Air purifiers
- Televisions

ePIR™ Motion Detection Zdots® Single Board Computer

ZEPIR0AAS01SBCG

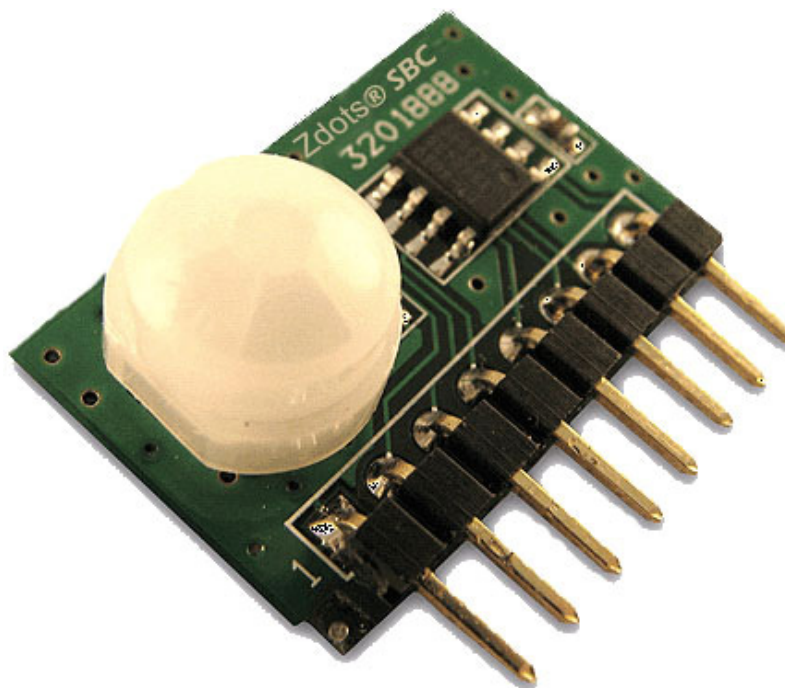

The unique features of the Z8 Encore! XP® MCU have permitted a revised look at the traditional PIR based motion detector design. Combined with innovative software techniques, this new approach has overcome the typical performance limitations of the traditional design.

This "fresh" look has produced a revolutionary step in PIR detector technology called:

ePIR™ with Sigma Delta Technology™

ePIR with Sigma Delta Technology combines the high performance and rich peripheral set of the Z8F042A Encore! XP MCU with powerful new motion detection software algorithms to provide exceptional motion detection performance.

Taking full advantage of the high processing capabilities of the Z8F042A MCU, ePIR with Sigma-Delta Technology uses a powerful new statistical processing method to provide superior sensitivity and stability vs. traditional solutions.

The software automatically adapts to the environment eliminating the need for discrete temperature compensation.

APPLICATIONS

Lighting Control

- Conveniently turn lights on automatically
- Reduce energy consumption by automatically turning off lights when people are not in the room
- Lights do not turn on when ambient light is sufficiently high
- Adjustable delay from 1 second to 128 minutes

Access Control

- Sense when someone approaches a controlled entry door
- Automatically unlock the door from one side while maintaining access control on the other
- Eliminates need for readers on both sides of the door

Direct interface to the PIR sensor provides a true, unaltered signal, allowing the software to identify and react to drift, sensor stability and other false alarm sources.

This direct interface also eliminates the need for external components including large electrolytic capacitors; improving reliability and ensuring the smallest possible form factor.

ePIR™ Motion Detection Zdots® Single Board Computer Block Diagram

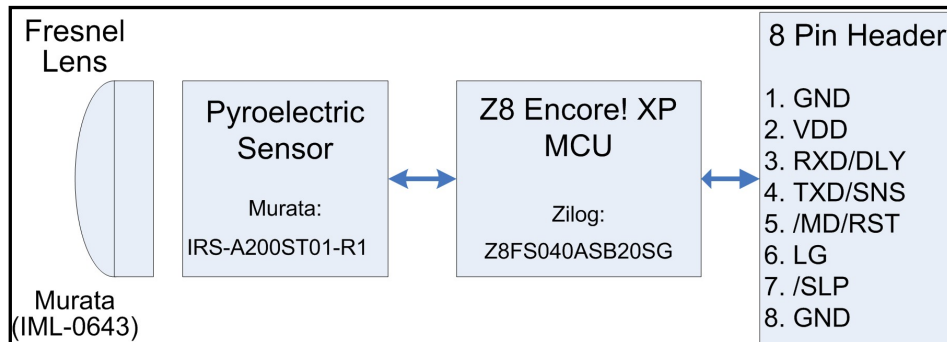

The ePIR Motion Detection Zdots SBC uses a Fresnel lens to break up the radiated IR energy into multiple concentrated images. These images are refracted on to the element of the PIR sensor which generates a signal based on the change in energy. The signal is fed directly to the Z8 Encore! XP MCU where it is analyzed by the motion detection algorithms to determine if it is from a valid source.

Parameters for sensitivity and output timing are provided through a simple hardware interface or more advanced settings and status are available through a serial interface mode.

Modes of Operation

Hardware Interface Mode

- Simple configuration via signal pins
- Allows basic adjustments of sensitivity, delay and ambient light threshold
- SLEEP mode to reduce power consumption (/SLP)
- Digital output (/MD)
- Analog inputs for Delay (DLY), Sensitivity (SNS) and Light Gate (LG)

Serial Interface Mode

- Advanced configuration and status via serial interface
- /MD, LG and /SLP remain functional
- The serial interface runs at: 9600 bps, no parity, 8 data bits and 1 stop bit
- Provides access to additional features:
 - Wider selection of activation times, sensitivity and range
 - Low frequency rejection
 - Pulse count
 - Directional detection

Dynamic PIR Sensor Stabilization

In traditional motion detection designs, critical information about the PIR sensor health and stability is lost. With a direct interface to the PIR sensor, the ePIR Motion Detection Zdots SBC is able to dynamically monitor the PIR signal to determine when it has stabilized. This significantly reduces the required power-on stabilization time.

Detection Pattern

The lens on the ePIR Motion Detection Zdots Single Board Computer provides a typical range of 5 m x 5 m with a 60 degree angle. The actual distance is dependent on the sensitivity setting of the ePIR Motion Detection Zdots SBC.

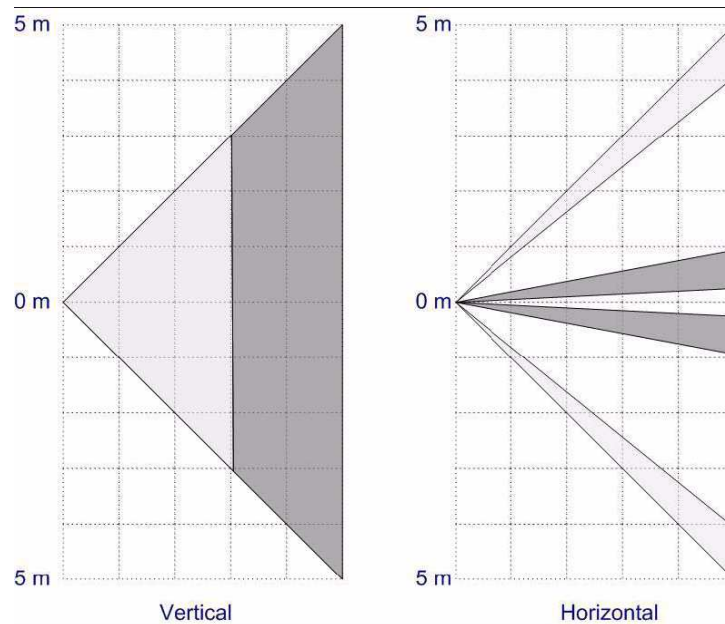

Electrical Characteristics

- Power supply: 2.7 V to 3.6 V
- Supply current: 8.9 mA (typical)
- Supply current in SLEEP Mode: 2.3 mA
- PIR Stabilization Timer: Dynamic
- Output Drive Current: +/- 25 mA
- Temperature Range: 0 °C to 70 °C

Ordering Information

Order the ePIR Motion Detection Zdots Single Board Computer from your local Zilog Distributor using the part numbers below. For more information, or to download product collateral and/or software, please visit us at www.zilog.com.

| Part Number | Description |
|-----------------|---|
| ZEPIR0AAS01SBCG | ePIR™ Motion Detection Zdots® Single Board Computer |
| ZEPIR000101ZCOG | ePIR™ Motion Detection Zdots® Single Board Computer Development Kit |

Documentation

The collateral referenced below is a sample of the documentation available for the ePIR Motion Detection Zdots Single Board Computer. For a complete listing of all available application notes, product specifications, user manuals, and sample libraries, please visit us at www.zilog.com.

| Document Number | Description |
|-----------------|---|
| PS0284 | ePIR™ Motion Detection Zdots® Single Board Computer Product Specification |
| UM0223 | ePIR™ Motion Detection Zdots® Single Board Computer Development Kit User Manual |
| PS0228 | Z8 Encore! XP® F082A Series Product Specification |



Warning: DO NOT USE IN LIFE SUPPORT

LIFE SUPPORT POLICY

ZILOG'S PRODUCTS ARE NOT AUTHORIZED FOR USE AS CRITICAL COMPONENTS IN LIFE SUPPORT DEVICES OR SYSTEMS WITHOUT THE EXPRESS PRIOR WRITTEN APPROVAL OF THE PRESIDENT AND GENERAL COUNSEL OF ZILOG CORPORATION.

As used herein

Life support devices or systems are devices which (a) are intended for surgical implant into the body, or (b) support or sustain life and whose failure to perform when properly used in accordance with instructions for use provided in the labeling can be reasonably expected to result in a significant injury to the user. A critical component is any component in a life support device or system whose failure to perform can be reasonably expected to cause the failure of the life support device or system or to affect its safety or effectiveness.

Document Disclaimer

©2008 by Zilog, Inc. All rights reserved. Information in this publication concerning the devices, applications, or technology described is intended to suggest possible uses and may be superseded. ZILOG, INC. DOES NOT ASSUME LIABILITY FOR OR PROVIDE A REPRESENTATION OF ACCURACY OF THE INFORMATION, DEVICES, OR TECHNOLOGY DESCRIBED IN THIS DOCUMENT. ZILOG ALSO DOES NOT ASSUME LIABILITY FOR INTELLECTUAL PROPERTY INFRINGEMENT RELATED IN ANY MANNER TO USE OF INFORMATION, DEVICES, OR TECHNOLOGY DESCRIBED HEREIN OR OTHERWISE. The information contained within this document has been verified according to the general principles of electrical and mechanical engineering.

ePIR, Z8 Encore! XP, and Zdots are trademarks or registered trademarks of Zilog, Inc. All other product or service names are the property of their respective owners.

Engineering Notes:



EMBEDDED IN LIFE
WWW.ZILOG.COM | 408.513.1500

Zilog and the Zilog logo are registered trademarks of Zilog, Inc. in the United States and in other countries.

ePIR, Z8 Encore! XP, and Zdots are the trademarks or registered trademarks of Zilog, Inc. All other product or service names are the property of their respective owners. ©Zilog, Inc., 2008. All rights reserved.