



Chipsmall Limited consists of a professional team with an average of over 10 year of expertise in the distribution of electronic components. Based in Hongkong, we have already established firm and mutual-benefit business relationships with customers from,Europe,America and south Asia,supplying obsolete and hard-to-find components to meet their specific needs.

With the principle of "Quality Parts,Customers Priority,Honest Operation,and Considerate Service",our business mainly focus on the distribution of electronic components. Line cards we deal with include Microchip,ALPS,ROHM,Xilinx,Pulse,ON,Everlight and Freescale. Main products comprise IC,Modules,Potentiometer,IC Socket,Relay,Connector.Our parts cover such applications as commercial,industrial, and automotives areas.

We are looking forward to setting up business relationship with you and hope to provide you with the best service and solution. Let us make a better world for our industry!



## Contact us

Tel: +86-755-8981 8866 Fax: +86-755-8427 6832

Email & Skype: info@chipsmall.com Web: www.chipsmall.com

Address: A1208, Overseas Decoration Building, #122 Zhenhua RD., Futian, Shenzhen, China



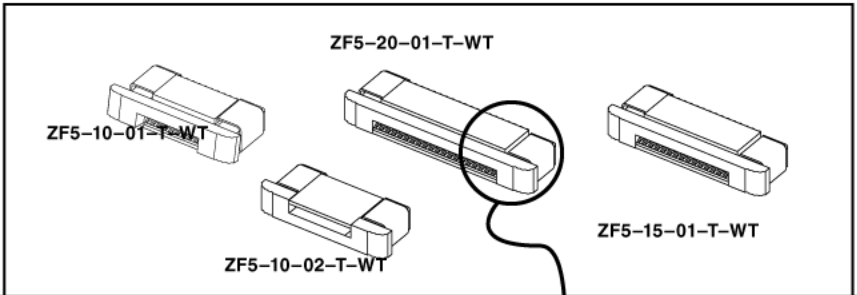

# 0,50mm ZIF FPC/FFC SOCKET ZF5 SERIES

## SPECIFICATIONS

For complete specifications and recommended PCB layouts see [www.samtec.com?ZF5](http://www.samtec.com?ZF5)

**Insulator Material:**

High Temperature Nylon



**Contact Material:**

Phosphor Bronze

**Plating:**

Tin/Lead over 50µ" (1,27µm) Ni

**Weld Tab:**

Brass

**Operating Temp Range:**

-55°C to +105°C

**Processing:**

**Max Processing Temp:** 230°C for 60 seconds

**Lead-Free Solderable:** No. Call Samtec

**SMT Lead Coplanarity:** (0,10mm) .004" max

**Mates with:**

FJH, ZFHF and flex cable with stiffener thickness of (0,30mm) .012"

## APPLICATION

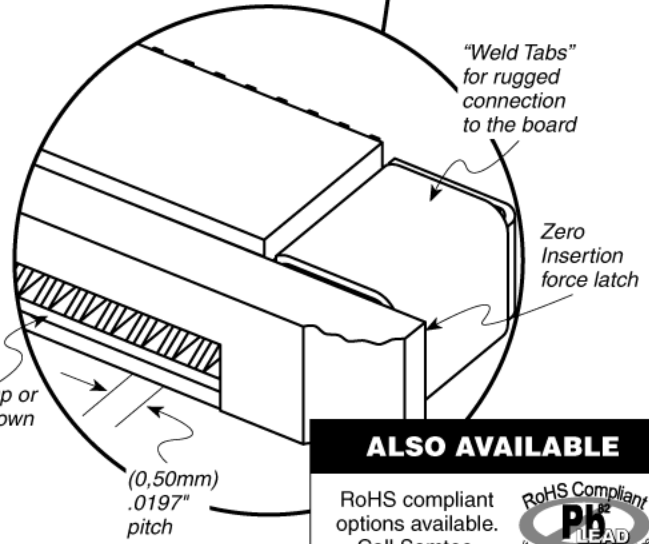
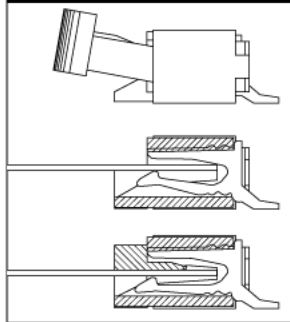

## ALSO AVAILABLE

RoHS compliant options available. Call Samtec.



ZF5	NO. OF POSITIONS	LEAD STYLE	PLATING OPTION	WT	OPTION
	-10, -15, -16, -18, -20, -22, -25, -30, -43 (Call Samtec for other sizes.)	-01 = Contact Bottom -02 = Contact Top -03 = Vertical	-T = Tin/Lead	-WT = Weld Tab	-TR = Tape & Reel Packaging

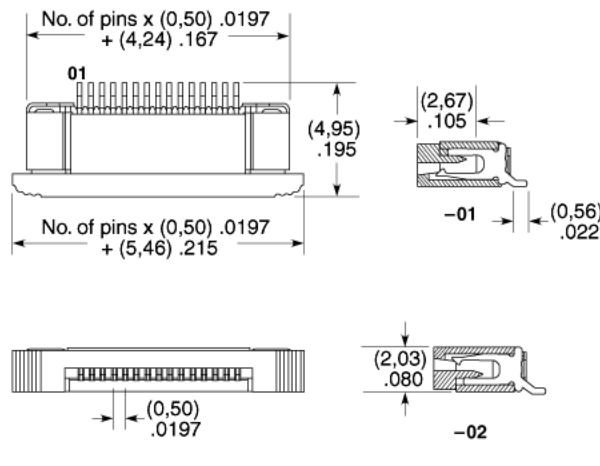

**Note:** Some lengths, styles and options are non-standard, non-returnable.

*Due to technical progress, all designs, specifications and components are subject to change without notice.*

**WWW.SAMTEC.COM**