



Chipsmall Limited consists of a professional team with an average of over 10 year of expertise in the distribution of electronic components. Based in Hongkong, we have already established firm and mutual-benefit business relationships with customers from,Europe,America and south Asia,supplying obsolete and hard-to-find components to meet their specific needs.

With the principle of “Quality Parts,Customers Priority,Honest Operation,and Considerate Service”,our business mainly focus on the distribution of electronic components. Line cards we deal with include Microchip,ALPS,ROHM,Xilinx,Pulse,ON,Everlight and Freescale. Main products comprise IC,Modules,Potentiometer,IC Socket,Relay,Connector.Our parts cover such applications as commercial,industrial, and automotives areas.

We are looking forward to setting up business relationship with you and hope to provide you with the best service and solution. Let us make a better world for our industry!



Contact us

Tel: +86-755-8981 8866 Fax: +86-755-8427 6832

Email & Skype: info@chipsmall.com Web: www.chipsmall.com

Address: A1208, Overseas Decoration Building, #122 Zhenhua RD., Futian, Shenzhen, China





ZHX1010

SIR Transceiver

Product Specification

PS015105-0702



This publication is subject to replacement by a later edition. To determine whether a later edition exists, or to request copies of publications, contact:

ZiLOG Worldwide Headquarters

532 Race Street
San Jose, CA 95126-3432
Telephone: 408.558.8500
Fax: 408.558.8300
www.ZiLOG.com

ZiLOG is a registered trademark of ZiLOG Inc. in the United States and in other countries. All other products and/or service names mentioned herein may be trademarks of the companies with which they are associated.

Document Disclaimer

©2002 by ZiLOG, Inc. All rights reserved. Information in this publication concerning the devices, applications, or technology described is intended to suggest possible uses and may be superseded. ZiLOG, INC. DOES NOT ASSUME LIABILITY FOR OR PROVIDE A REPRESENTATION OF ACCURACY OF THE INFORMATION, DEVICES, OR TECHNOLOGY DESCRIBED IN THIS DOCUMENT. ZiLOG ALSO DOES NOT ASSUME LIABILITY FOR INTELLECTUAL PROPERTY INFRINGEMENT RELATED IN ANY MANNER TO USE OF INFORMATION, DEVICES, OR TECHNOLOGY DESCRIBED HEREIN OR OTHERWISE. Devices sold by ZiLOG, Inc. are covered by warranty and limitation of liability provisions appearing in the ZiLOG, Inc. Terms and Conditions of Sale. ZiLOG, Inc. makes no warranty of merchantability or fitness for any purpose. Except with the express written approval of ZiLOG, use of information, devices, or technology as critical components of life support systems is not authorized. No licenses are conveyed, implicitly or otherwise, by this document under any intellectual property rights.



Table of Contents

Description	1
Features	1
Pin Descriptions	2
VCC Positive Supply	2
GND Ground	2
TAB	2
TXD Transmit Data	2
RXD Receive Data	3
SD Shutdown	3
LEDA IRED Driver Anode	3
Recommended Application Circuit	4
Electrical and Timing Specifications	5
Transceiver Performance	7
Mechanical Drawings	8
ZHX1010 Soldering and Cleaning Recommendations	9
Reflow Soldering	9
Manual Soldering	9
Cleaning	10
ZHX1010 Packing, Storage, and Baking Recommendations	10
Storage	10
Baking	10
Moisture Prevention Guidelines	11
Taping Specifications	12
Ordering Information	13
Customer Feedback Form	14
Customer Information	14
Product Information	14
Return Information	14
Problem Description or Suggestion	14



List of Figures

Figure 1.	Application Block Diagrams	4
Figure 2.	Typical Radiant Intensity (I_E) Versus Angle	7
Figure 3.	Typical Irradiance (E_e) Versus Angle at BER = 1 in 10^{-8}	7
Figure 4.	ZHX1010 Mechanical Drawing	8
Figure 5.	Temperature Profile at the Top Surface of ZHX1010	9
Figure 6.	ZHX1010 Transceiver Packaging	11
Figure 7.	ZHX1010 Reel Dimensions (Unit: mm)	12
Figure 8.	ZHX1010 Tape Dimensions and Configuration (Unit: mm)	13

List of Tables

Table 1.	Pin Out for the ZHX1010 SIR Transceiver	2
Table 2.	Absolute Maximum Ratings	5
Table 3.	Recommended Operating Conditions	5
Table 4.	Electrical Characteristics	5



Description

The ZiLOG ZHX1010 SIR transceiver is the ideal choice for applications in today's ultra-compact and power-conscious portable products, such as mobile phones, digital cameras, portable printers, handheld computers, or personal data assistants (PDA). Designed to support the SIR (serial infrared) Infrared Data Association (IrDA) Data standard (2.4–115.2 Kbps, 1 meter minimum), LocalTalk™, and Sharp ASK™ modes, the transceiver combines an infrared emitting diode (IRED), a PIN photodiode detector, a digital AC coupled IRED driver, and a receiver/decoder with noise discrimination circuitry in a single, miniature package.

The ZiLOG ZHX1010 SIR transceiver provides an efficient implementation of the IrDA-Data standard in a small footprint format. Application circuit space is also minimized, as only two external resistors and one capacitor are needed to complete the IrDA transceiver solution. The ZHX1010 SIR transceiver meets the IEC825-Class 1 Eye Safety limits.

An external shield minimizes radio frequency interference (RFI) and electromagnetic interference (EMI) problems.

Features

- Compliant to IrDA SIR Specifications (2.4–115.2 Kbps, 1 meter minimum)
- Wide supply voltage range, 2.4 to 5.5 V
- Low power, 90 μ A (typical) at 3 V
- Slim-shield option: 9.9 mm long x 3.7 mm wide x 4.0 mm high
- Two external components: one resistor and one capacitor
- Extended operating temperature range (–30 °C to +85 °C)
- Meets the IEC 825-1 Class 1 Eye Safety Specifications

Pin Descriptions

The ZHX1010 SIR transceiver uses the pins listed in Table 1. The pins are described in this section.

Table 1. Pin Out for the ZHX1010 SIR Transceiver

Pin	Name	Function	I/O
1	LEDA	IREDA anode	—
2	TXD	Transmitter input	I
3	RXD	Receiver output	O
4	SD	Enables shutdown mode	I
5	V _{CC}	Supply voltage	—
6	GND	Ground	—
—	TAB	Shield ground	—

V_{CC} Positive Supply

(Power)

Connect to positive power supply (2.4–5.5 V).

Place a .33- μ F ceramic bypass capacitor (optional) as close as possible to the V_{CC} pin.

GND Ground

(Power)

Connect to ground of the power supply. A solid ground plane is recommended for proper operation.

TAB

(Shield)

The Shield tab must be soldered to the ground plane.

TXD Transmit Data

(Input, active high)

This CMOS input is used to transmit serial data.



This input has an internal pull-down resistor that is disabled (open-circuited) during shutdown. TXD has integrated digital AC coupling that prevents inadvertent “always on” IREDs; therefore, no external AC coupling components are required for input signals between GND and V_{CC} .

RXD Receive Data

(Output, active low).

This output indicates received serial data. It is a tri-state, slew rate controlled CMOS output (tri-stated during shutdown) driver capable of driving a standard CMOS or LSTTL load. No external resistor is required.

SD Shutdown

(Input, active high)

This input is used to place the integrated circuit into shutdown mode. Maximum current draw in shutdown mode is 1 μ A. Module shutdown current might be limited by the choice of capacitor used from V_{CC} to ground. A 0.1-mF ceramic capacitor with very high DC impedance (1–10 G ohm) is required to minimize shutdown current to nanoamp levels. During shutdown, the output is tri-stated, and the TXD input pull-down resistor is disabled (open circuited).

LEDA IRED Driver Anode

(Output, active low).

This output is internally connected to the IRED anode and is connected to LEDA through a current limiting resistor. Current to the IRED must be limited to a maximum of 500 mA (20% duty cycle maximum). The maximum voltage on this pad is limited to +5.5 volts or V_{CC} .

Recommended Application Circuit

Figure 1 shows applications for the ZHX1010 SIR transceiver.

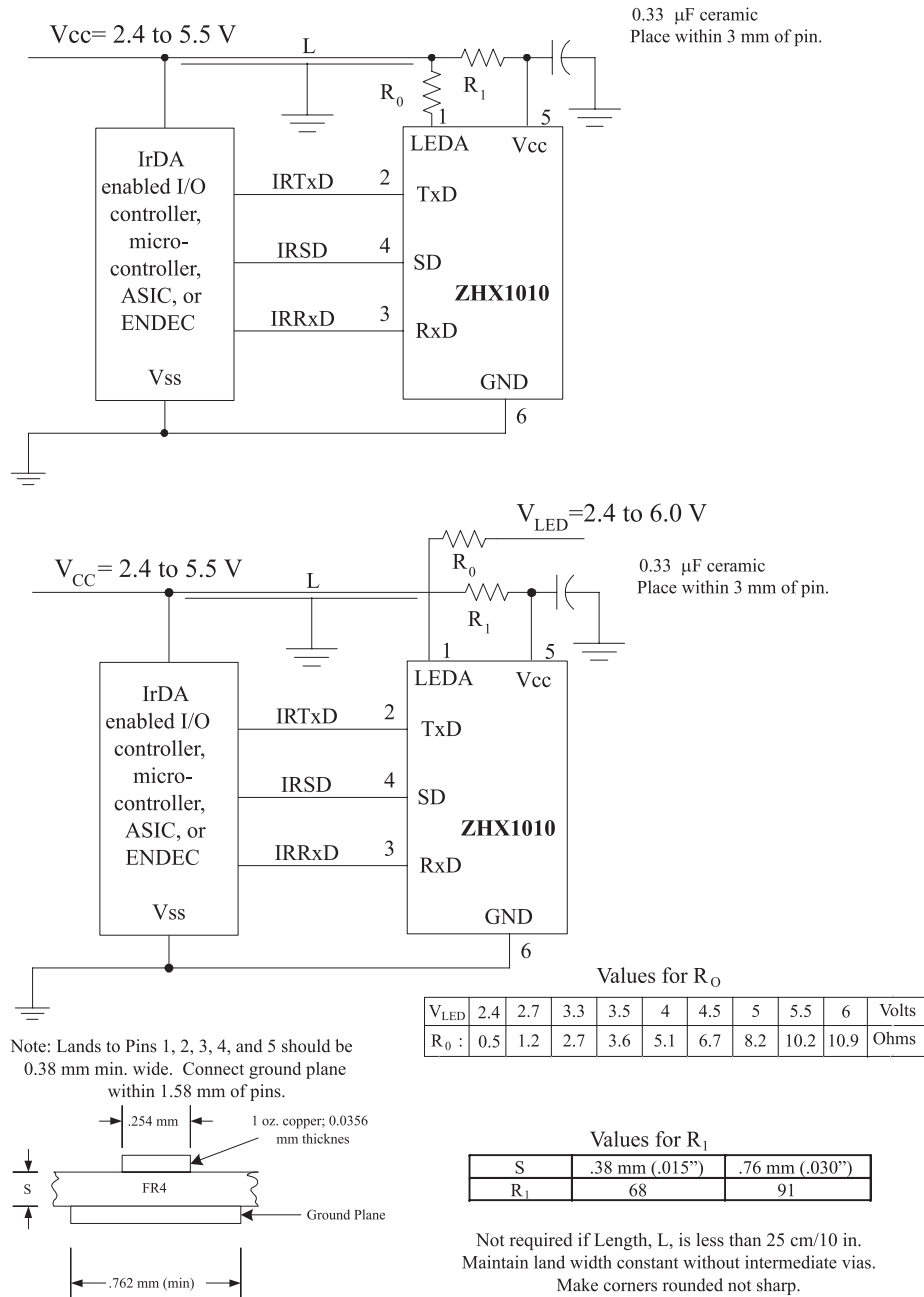

Figure 1. Application Block Diagrams



Electrical and Timing Specifications

Table 2 through Table 4 present the electrical and timing specifications for the ZHX1010 SIR transceiver.

Table 2. Absolute Maximum Ratings

Parameter	Symbol	Minimum	Maximum	Unit	Comment
Supply Voltage	V _{CC}	-0.3	6.0	V	
Power Dissipation	P _D		500	mW	
Junction Temperature	T _J		125	°C	
Storage Temperature		-55	85	°C	
Solder Temperature (10 seconds)			230	°C	
IRED Current	I _{LED}		700	mA	20% duty cycle
Any Pin Voltage		-0.5	V _{CC} +0.5	V	

Table 3. Recommended Operating Conditions

Parameter	Symbol	Minimum	Maximum	Unit
Supply Voltage	V _{CC}	2.4	5.5	V
Ambient Operating Temperature	T _A	-30	85	°C

Table 4. Electrical Characteristics

Parameter	Condition	Min	Typical	Max	Unit
Operating Current (I _{CC})	No load, SD = TXD = "0" 3.0 V; T = 25 °C		90	150	μA
Shutdown Current (I _{SD})	SD = "V _{CC} ", Photodiode input current = 0			1	μA
Peak Current Transmit (I _{LED}) Transmitter			300		mA
Radiant Intensity (I _E)(±15°)	LED Peak I _F = 300 mA, TXD Logic "High"	40		100	mW/sr
Radiant Intensity	TXD Logic "Low"			0.3	mW/sr
Angle of Half Intensity			20		°



Table 4. Electrical Characteristics (Continued)

Parameter	Condition	Min	Typical	Max	Unit
Optical Rise/Fall time			40		ns
Peak Wavelength		850	875	900	nm
Optical Overshoot				3	%
Receiver					
Detection Threshold Irradiance	$\pm 15^\circ$		2	3	$\mu\text{W}/\text{cm}^2$
Overload Irradiance		500			$\mu\text{W}/\text{cm}^2$
Sunlight Ambient Rejection	No modulation	500			$\mu\text{W}/\text{cm}^2$
Digital Input/Output					
Input High (Logic 1) Voltage, V_{IH}	TXD, SD	$0.6 V_{CC}$		$V_{CC} + 0.5 \text{ V}$	V
Input Low (Logic 0) Voltage, V_{IL}	TXD, SD	-0.5		$0.2 V_{CC}$	V
Output High (Logic 1) Voltage, V_{OH}	RXD/ = -250 mA @ 1.8 V	2.2			V
Output Low (Logic 0) Voltage, V_{OL}	RXD/ = 1 mA			0.4	V
Output Leakage (RXD, Anode)	SD = "1"	-1		+1	μA
Input Leakage	SD, TXD = "0"	-1		+1	μA
Input Current	TXD = "1", SD = "0"	4		100	μA
AC Parameters ($C_{LOAD} = 25 \text{ pF}$)					
Transmit Output Pulse Width	TXD = 1 > 200 ms	18		150	μs
Recovery Delay from Shutdown to Full Sensitivity ($T_{RECOVERY}$)	SD = "1" \rightarrow "0"			200	μs
Receiver Latency (T_L)			100		μs
Rise Time (T_R)	$V_{CC} = 1.8\text{--}5.5 \text{ V}$		100		ns
Fall Time (T_F)	$V_{CC} = 1.8\text{--}5.5 \text{ V}$		100		ns
Pulse Width (T_W) (RXD)	$I_{DET} = 1 \mu\text{A}$, 1.6-ms pulse	1.1	1.6	3.9	μs
Pulse Jitter (T_J) (RXD)	Irradiance = $3.5 \text{ mW}/\text{cm}^2$ – $500 \text{ mW}/\text{cm}^2$			400	ns
Pulse Delay (T_D) (RXD)	Irradiance = $3.5 \text{ mW}/\text{cm}^2$ – $500 \text{ mW}/\text{cm}^2$			1.8	μs

Unless otherwise noted: $V_{CC}/LEDA=2.4 \text{ V}$ to 5.5 V , $GND=0 \text{ V}$, $T_A=-30^\circ\text{C}$ to 85°C



Transceiver Performance

Figure 2 and Figure 3 show the performance of the ZHX1010 SIR transceiver.

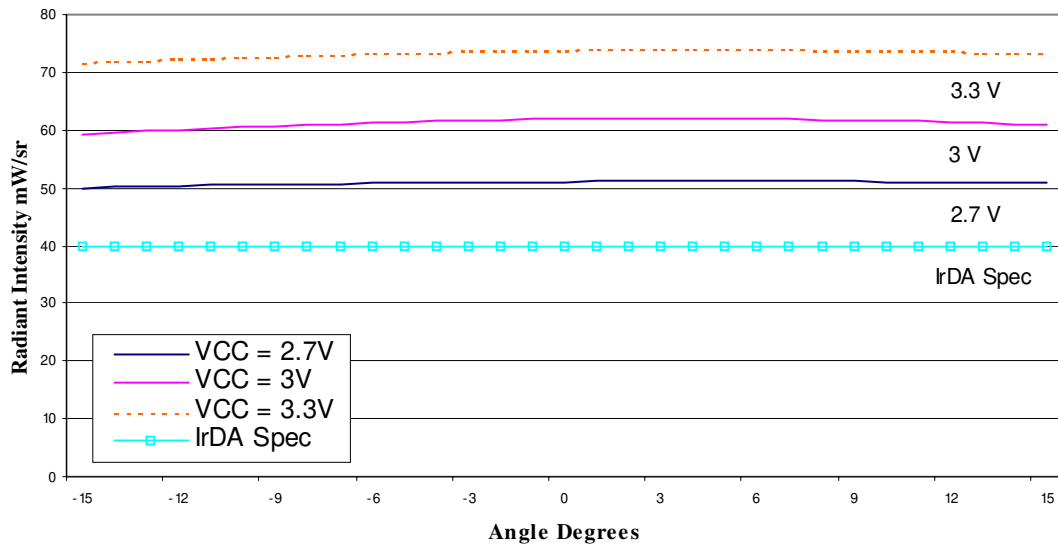

Figure 2. Typical Radiant Intensity (I_E) Versus Angle

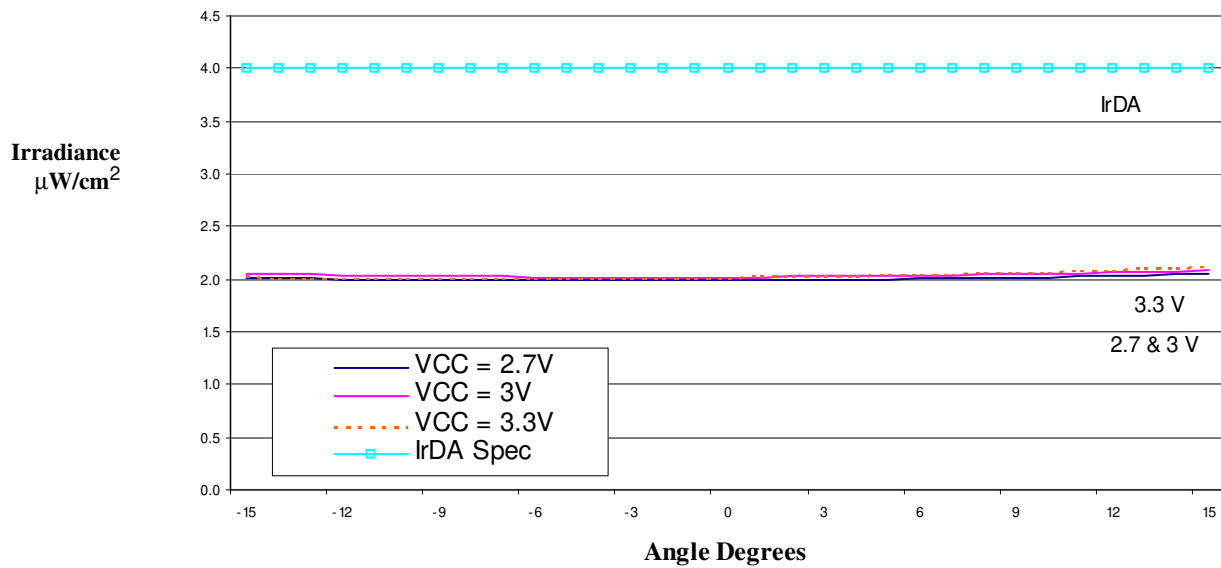

Figure 3. Typical Irradiance (E_e) Versus Angle at BER = 1 in 10^{-8}



Mechanical Drawings

Figure 4 shows the mechanical drawings for the ZHX1010 SIR transceiver.

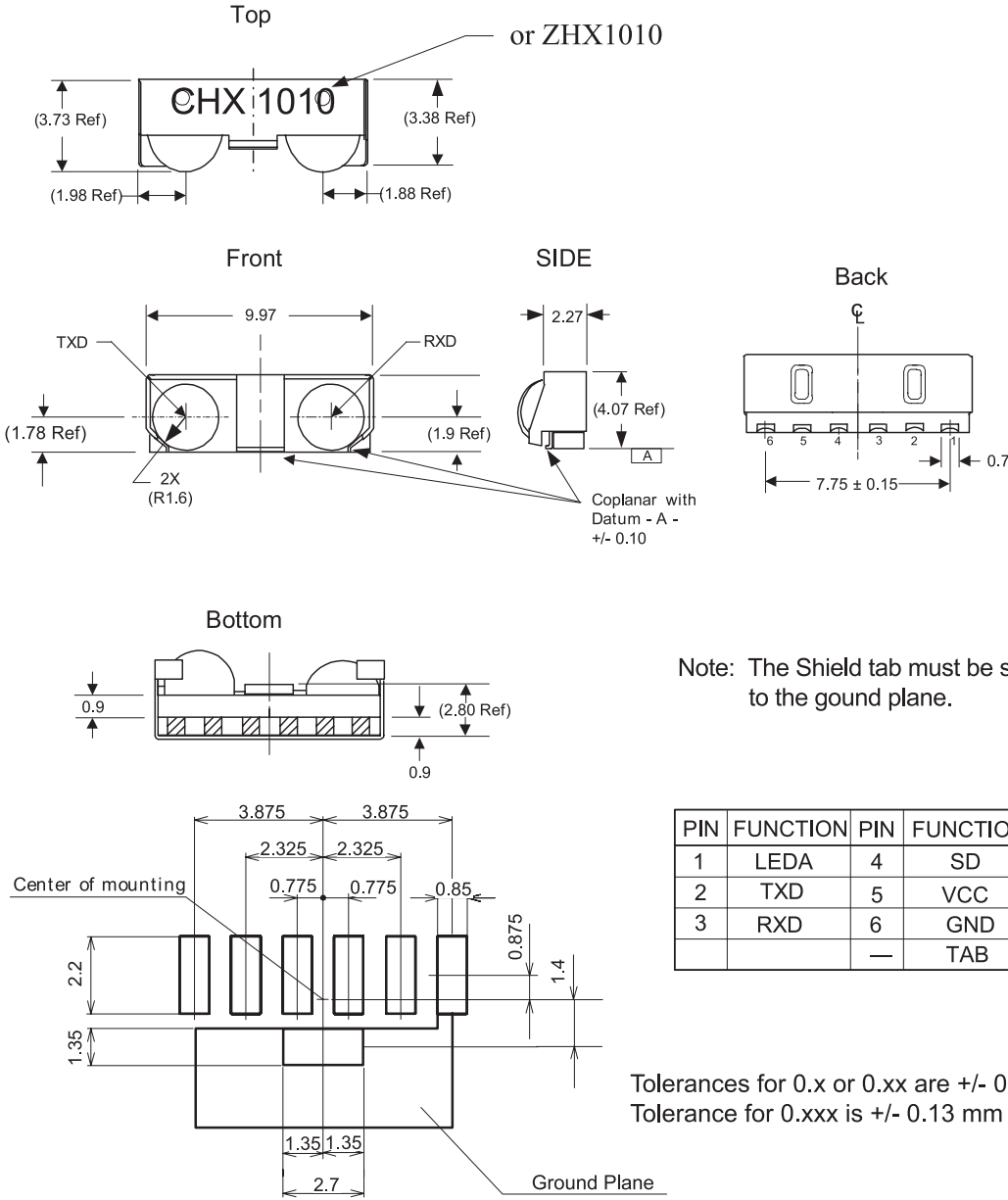

Figure 4. ZHX1010 Mechanical Drawing

ZHX1010 Soldering and Cleaning Recommendations

Follow these recommendations to maintain the performance of the ZHX1010 SIR transceiver.

Reflow Soldering

- Reflow soldering paste is recommended:
Melting temperature: 178 °C ~ 192 °C
Composition: Sn 63%, Pb 37%
- The recommended thickness of the metal mask is between 0.2 mm and 0.25 mm for screen printing.
- Number of soldering times: 2 times *maximum*
- The temperature profile at the top surface of ZHX1010, shown in Figure 5, is recommended.

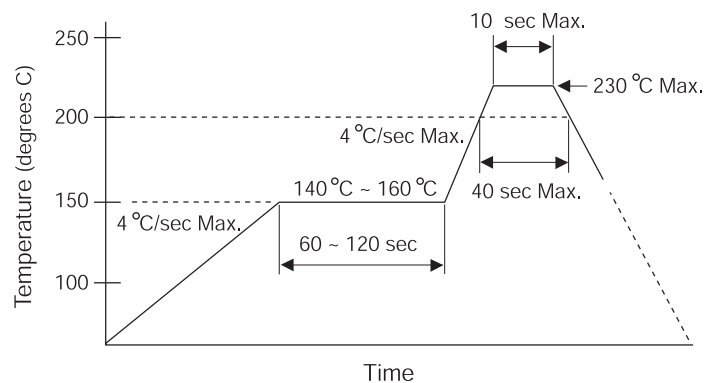

Figure 5. Temperature Profile at the Top Surface

Manual Soldering

- Use 63/37 or silver solder.
- Use a soldering iron of 25 W or smaller. Adjust the temperature of the soldering iron below 300 °C.
- Finish soldering within 3 seconds.
- Handle only after ZHX1010 has cooled off.



Cleaning

Perform cleaning after soldering under the following conditions:

- Cleaning agent: Alcohol
- Temperature and time: 30 seconds below 50 °C or 3 minutes below 30 °C
- Ultrasonic cleaning: Below 20 W

ZHX1010 Packing, Storage, and Baking Recommendations

Follow these recommendations to maintain the performance of the ZHX1010 SIR transceiver.

Storage

To avoid moisture absorption, ZHX1010 reels must remain in the original, unopened moisture-proof packing. Parts must be soldered within 48 hours after unpacking. Reels that have been unpacked, but will not be soldered within 48 hours, must be stored in a desiccator.

Baking

Parts that have been stored over 12 months or unpacked over 48 hours must be baked under the following guidelines.

Reels

60 °C for 48 hours or more

Loose Parts

- 100 °C for 4 hours or more
or
- 125 °C for 2 hours or more
or
- 150 °C for 1 hour or more

Moisture Prevention Guidelines

In order to avoid moisture absorption during transportation and storage, ZHX1010 reels are packed in aluminum envelopes (see Figure 6) that contain a desiccant with a humidity indicator. While this packaging is an impediment to moisture absorption, it is by no means absolute, and no warranty is implied. The user should store these parts in a controlled environment to prevent moisture entry. Please read the label on the aluminum bag for indicator instructions.

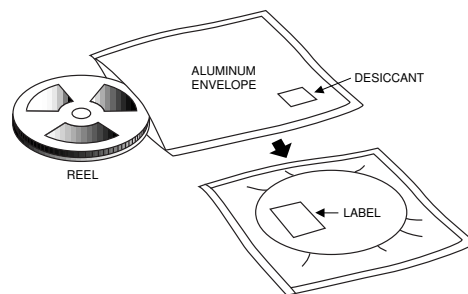

Figure 6. ZHX1010 Transceiver Packaging

Taping Specifications

Figure 7 and Figure 8 show the reel dimensions and tape dimensions and configuration for the ZHX1010.

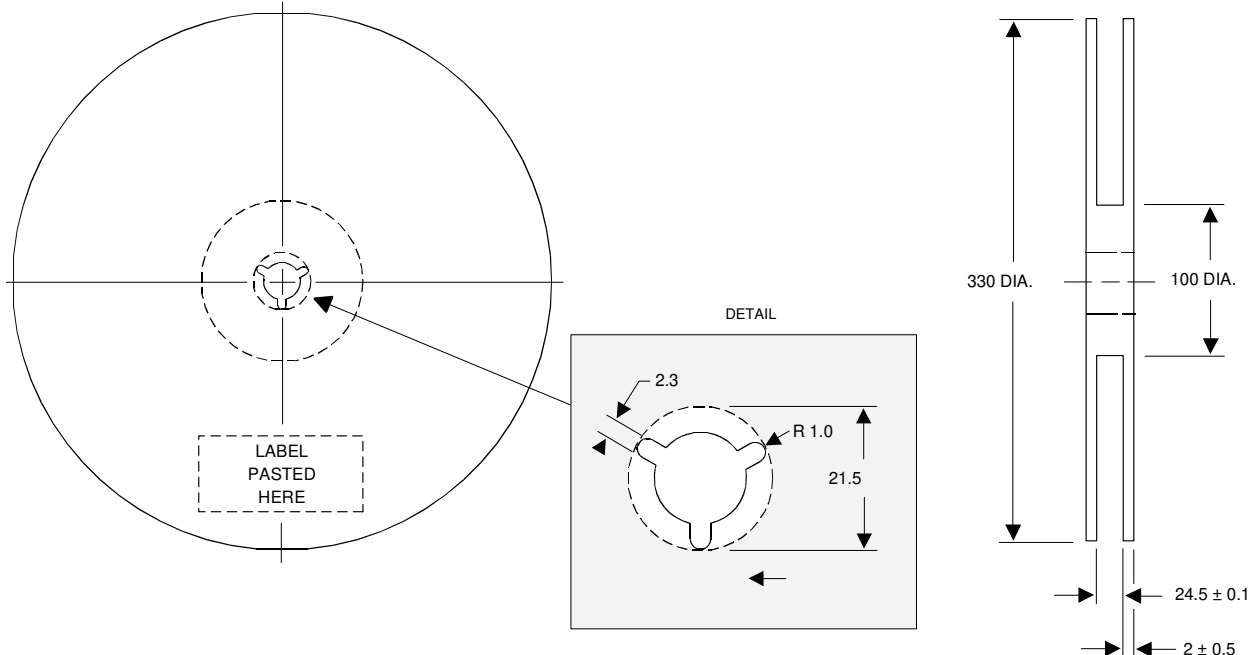

Figure 7. ZHX1010 Reel Dimensions (Unit: mm)

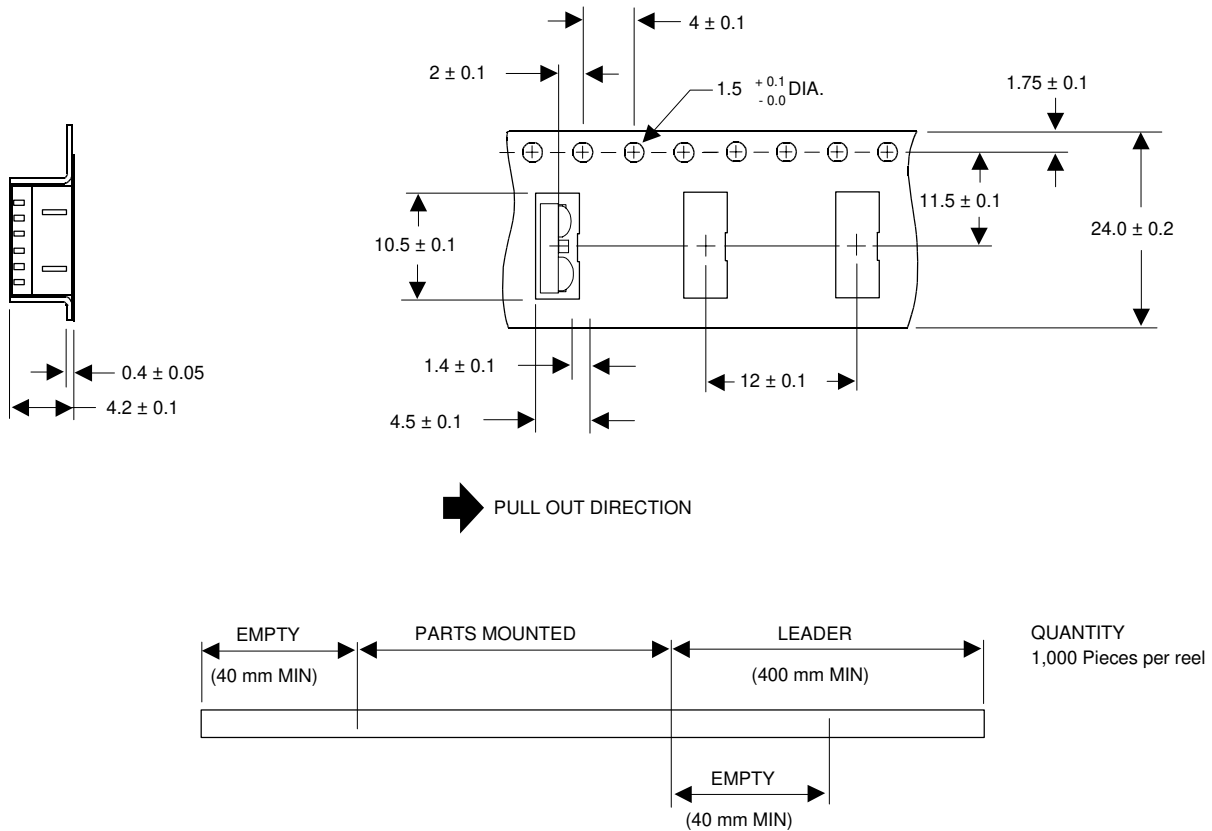

Figure 8. ZHX1010 Tape Dimensions and Configuration (Unit: mm)

Ordering Information

To order ZHX1010 (formerly Calibre CHX1010), use ZiLOG part number ZHX1010MV115THTR.

- **Notes:** In order to ensure the lowest possible lead times, ZiLOG uses two different fab sources for the transceiver IC. Both of these ICs have been extensively tested and qualified to meet the ZHX1010 SIR transceiver specifications.



Customer Feedback Form

If you experience any problems while operating the ZHX1010 SIR transceiver, or if you note any inaccuracies while reading this product specification, please copy and complete this form, then mail or fax it to ZiLOG (see "Return Information," below). We also welcome your suggestions!

Customer Information

Name	Country
Company	Phone
Address	Fax
City/State/Zip	email

Product Information

Serial # or Board Fab #/Rev #
Software Version
Document Number
Host Computer Description/Type

Return Information

ZiLOG
System Test/Customer Support
532 Race Street
San Jose, CA 95126-3432
Fax: (408) 558-8300
Email: tools@zilog.com

Problem Description or Suggestion

Provide a complete description of the problem or your suggestion. If you are reporting a specific problem, include all steps leading up to the occurrence of the problem. Attach additional pages as necessary.
