



Chipsmall Limited consists of a professional team with an average of over 10 year of expertise in the distribution of electronic components. Based in Hongkong, we have already established firm and mutual-benefit business relationships with customers from,Europe,America and south Asia,supplying obsolete and hard-to-find components to meet their specific needs.

With the principle of “Quality Parts,Customers Priority,Honest Operation,and Considerate Service”,our business mainly focus on the distribution of electronic components. Line cards we deal with include Microchip,ALPS,ROHM,Xilinx,Pulse,ON,Everlight and Freescale. Main products comprise IC,Modules,Potentiometer,IC Socket,Relay,Connector.Our parts cover such applications as commercial,industrial, and automotives areas.

We are looking forward to setting up business relationship with you and hope to provide you with the best service and solution. Let us make a better world for our industry!



## Contact us

Tel: +86-755-8981 8866 Fax: +86-755-8427 6832

Email & Skype: info@chipsmall.com Web: www.chipsmall.com

Address: A1208, Overseas Decoration Building, #122 Zhenhua RD., Futian, Shenzhen, China



## Brief Description

The ZIOL2401 is a line driver/level shifter IC that provides two independent HV\* I/O channels with a wide range of configurable system features. It addresses the physical layer of sensor/actuator systems in factory automation applications and is specifically designed to support the communication standard IO-Link<sup>†</sup>.

The output drivers are push-pull stages, which in tandem mode reach an  $R_{DSon}$  of less than 3.3Ω at all operational temperatures.

The configuration is stored in an on-chip EEPROM and automatically loaded into the ZIOL2401's control register during power up. The ZIOL2401 also provides status information, such as overload and over-temperature conditions. An integrated SPI interface supports access to configuration and status registers.

The ZIOL2401 is fabricated in a powerful CMOS mixed-signal technology that allows supply voltages up to 40V. The EEPROM read/write functionality is guaranteed within the full operating temperature range in combination with a low-voltage core supply of 3.3V.

## Features

- Configurable output current limitation 56mA to 410mA per channel
- Standard cable driver/ physical layer transceiver for IO-Link (master and device)
- Slew-rate controlled drivers
- Wide range for configurable feature set, which is automatically loaded after power on reset
- Onboard DC/DC converter
- IO-Link-specific WURQ<sup>‡</sup> detection
- On-chip registers and EEPROM for system configuration and status information
- SPI interface for accessing on-chip registers and EEPROM
- Digital interface: 3.3V output, 5V tolerant inputs
- IC temperature monitoring/diagnosis
- Over-current and over-temperature indication

## Benefits

- Configurable feature set
- Nonvolatile storage of system configuration
- Excellent electromagnetic compatibility (EMC) performance due to adjustable output slew rate control
- Low  $R_{DSon}$  of 3.3Ω in tandem mode
- Programmable limitation of driver output current
- DC/DC converter on-chip
- EEPROM read/write functionality within full operating temperature range
- Space saving 4x4mm<sup>2</sup> 24-pin QFN

## Available Support

- Evaluation Kits
- Application Notes

## Physical Characteristics

- Operation temperature: -40 to +85 °C
- Supply voltage 8.0V to 36.0V
- RoHS-compliant QFN 24 (4x4 mm) package

## ZIOL2401 Application Circuits

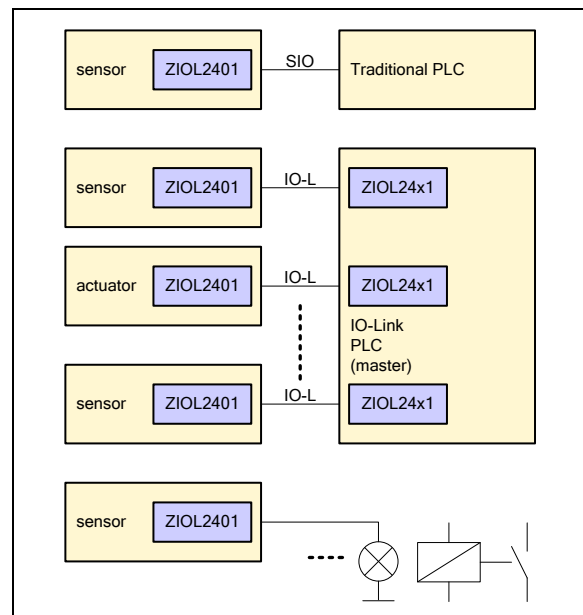

\* High Voltage (max. power supply / signal swing is 36 volt)

<sup>†</sup> IDT is a member of the IO-Link Community: [www.io-link.com](http://www.io-link.com)

<sup>‡</sup> IO-Link device wake-up

## Typical Applications

In field applications, the ZIOL2401 acts as a universal cable driver. The ZIOL2401 can support IO-Link communications as a physical-layer transceiver (PHY) for IO-Link devices and IO-Link masters.

Common applications:

- 24V line driver/level shifter
- IO-Link-compliant devices
- IO-Link-compliant masters

See the ZIOL2xxx IC Family Data Sheet for detailed technical information.

## ZIOL2401 Block Diagram

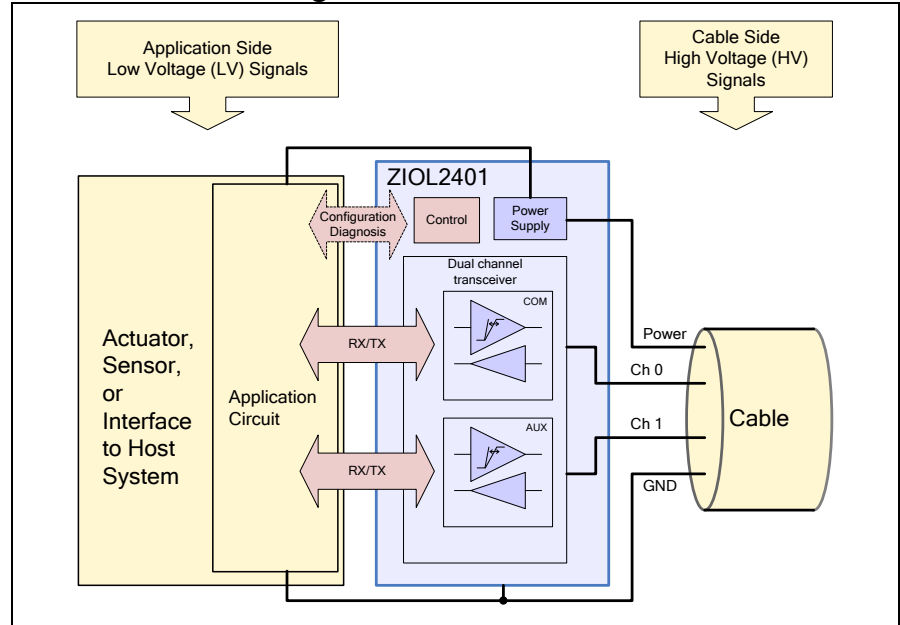

## Ordering Information

Product Sales Code	Description	Package
ZIOL2401BI1R	Dual Channel IO-Link compliant HV Line Driver, 4x4mm QFN24	13" reel
ZIOL2401BI1W	Dual Channel IO-Link compliant HV Line Driver, 4x4mm QFN24	7" reel
IO-Link Lab Kit V2.0 #3600100858	ZIOL2401 Lab Kit for detailed laboratory evaluation: configurable IC/Communication/Controller Board, USB cable; software is available for download from <a href="http://www.IDT.com">http://www.IDT.com</a> with a free customer login (see data sheet for details).	
ZIOL2401 Starter-Kit #3600100369	ZIOL2401 Starter Kit for product demonstration: USB stick, extension board, downloadable software	



**Corporate Headquarters**  
6024 Silver Creek Valley Road  
San Jose, CA 95138  
[www.IDT.com](http://www.IDT.com)

**Sales**  
1-800-345-7015 or 408-284-8200  
Fax: 408-284-2775  
[www.IDT.com/go/sales](http://www.IDT.com/go/sales)

**Tech Support**  
[www.IDT.com/go/support](http://www.IDT.com/go/support)

DISCLAIMER Integrated Device Technology, Inc. (IDT) reserves the right to modify the products and/or specifications described herein at any time, without notice, at IDT's sole discretion. Performance specifications and operating parameters of the described products are determined in an independent state and are not guaranteed to perform the same way when installed in customer products. The information contained herein is provided without representation or warranty of any kind, whether express or implied, including, but not limited to, the suitability of IDT's products for any particular purpose, an implied warranty of merchantability, or non-infringement of the intellectual property rights of others. This document is presented only as a guide and does not convey any license under intellectual property rights of IDT or any third parties.

IDT's products are not intended for use in applications involving extreme environmental conditions or in life support systems or similar devices where the failure or malfunction of an IDT product can be reasonably expected to significantly affect the health or safety of users. Anyone using an IDT product in such a manner does so at their own risk, absent an express, written agreement by IDT.

Integrated Device Technology, IDT and the IDT logo are trademarks or registered trademarks of IDT and its subsidiaries in the United States and other countries. Other trademarks used herein are the property of IDT or their respective third party owners. For datasheet type definitions and a glossary of common terms, visit [www.idt.com/go/glossary](http://www.idt.com/go/glossary). All contents of this document are copyright of Integrated Device Technology, Inc. All rights reserved.

## Document Revision History

Revision	Date	Description
2.20	August 28, 2015	Update for template and contact information. Update for kit order number and information about software download. Update for current limitation minimum. Minor edits for clarity.
	January 27, 2016	Changed to IDT branding.



**Corporate Headquarters**  
6024 Silver Creek Valley Road  
San Jose, CA 95138  
[www.IDT.com](http://www.IDT.com)

**Sales**  
1-800-345-7015 or 408-284-8200  
Fax: 408-284-2775  
[www.IDT.com/go/sales](http://www.IDT.com/go/sales)

**Tech Support**  
[www.IDT.com/go/support](http://www.IDT.com/go/support)

DISCLAIMER Integrated Device Technology, Inc. (IDT) reserves the right to modify the products and/or specifications described herein at any time, without notice, at IDT's sole discretion. Performance specifications and operating parameters of the described products are determined in an independent state and are not guaranteed to perform the same way when installed in customer products. The information contained herein is provided without representation or warranty of any kind, whether express or implied, including, but not limited to, the suitability of IDT's products for any particular purpose, an implied warranty of merchantability, or non-infringement of the intellectual property rights of others. This document is presented only as a guide and does not convey any license under intellectual property rights of IDT or any third parties.

IDT's products are not intended for use in applications involving extreme environmental conditions or in life support systems or similar devices where the failure or malfunction of an IDT product can be reasonably expected to significantly affect the health or safety of users. Anyone using an IDT product in such a manner does so at their own risk, absent an express, written agreement by IDT.

Integrated Device Technology, IDT and the IDT logo are trademarks or registered trademarks of IDT and its subsidiaries in the United States and other countries. Other trademarks used herein are the property of IDT or their respective third party owners. For datasheet type definitions and a glossary of common terms, visit [www.idt.com/go/glossary](http://www.idt.com/go/glossary). All contents of this document are copyright of Integrated Device Technology, Inc. All rights reserved.