



Chipsmall Limited consists of a professional team with an average of over 10 year of expertise in the distribution of electronic components. Based in Hongkong, we have already established firm and mutual-benefit business relationships with customers from,Europe,America and south Asia,supplying obsolete and hard-to-find components to meet their specific needs.

With the principle of “Quality Parts,Customers Priority,Honest Operation,and Considerate Service”,our business mainly focus on the distribution of electronic components. Line cards we deal with include Microchip,ALPS,ROHM,Xilinx,Pulse,ON,Everlight and Freescale. Main products comprise IC,Modules,Potentiometer,IC Socket,Relay,Connector.Our parts cover such applications as commercial,industrial, and automotives areas.

We are looking forward to setting up business relationship with you and hope to provide you with the best service and solution. Let us make a better world for our industry!



Contact us

Tel: +86-755-8981 8866 Fax: +86-755-8427 6832

Email & Skype: info@chipsmall.com Web: www.chipsmall.com

Address: A1208, Overseas Decoration Building, #122 Zhenhua RD., Futian, Shenzhen, China



Common Mode Filters

For general signal line/power line

ZJY series

Type: ZJY51R5

Issue date: September 2011

- All specifications are subject to change without notice.
 - Conformity to RoHS Directive: This means that, in conformity with EU Directive 2002/95/EC, lead, cadmium, mercury, hexavalent chromium, and specific bromine-based flame retardants, PBB and PBDE, have not been used, except for exempted applications.
-

Common Mode Filters

For General Signal Line / Power Line

Conformity to RoHS Directive

ZJY Series ZJY51R5

FEATURES

- A common mode filter for distortion-free removal of noise from transmitted signals. Best common mode filter for transmission of high quality signals.
- Best filter for countering the common mode noise resulting from data signal processing by PCs, phone equipment, etc.
- Highly appropriate for IC board mounting due to DIP type structure.
- Due to a maximum current tolerance of 2A, can also be used to counter power line noise.

APPLICATIONS

Personal computers, telephones, LANs, ISDNs, digital PBXs, electronic games, CTVs, CD-ROM drives, 8mm video equipment, and other electronic devices

PACKAGING STYLE AND QUANTITIES(Tube style)

Part No.	Quantity
ZJY51R5-2P-01	80 pieces
ZJY51R5-2PB-01	80 pieces
ZJY51R5-2PL-01	80 pieces
ZJY51R5-4P-01	40 pieces
ZJY51R5-M4PA-01	40 pieces
ZJY51R5-8PA-01	20 pieces

RECOMMENDED SOLDERING CONDITION

RECOMMENDED FLOW TEMPERATURE PROFILE FOR LEAD-FREE SOLDER

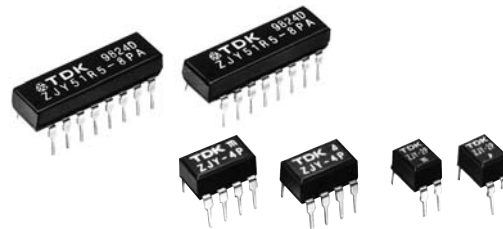
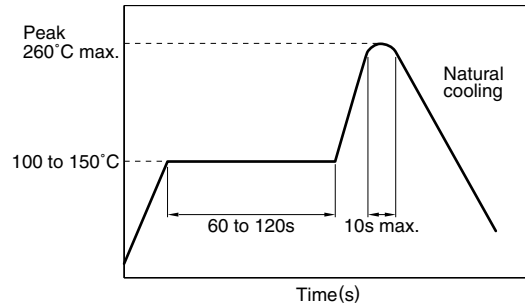

SHAPES AND DIMENSIONS

TRANSFER MOLD

ZJY51R5-2P-01, -2PB-01, -2PL-01

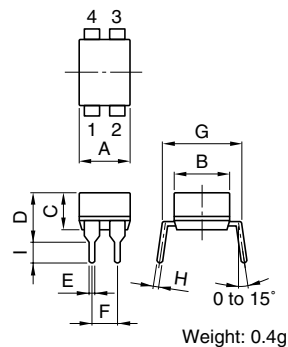

ZJY51R5-4P-01, -M4PA-01

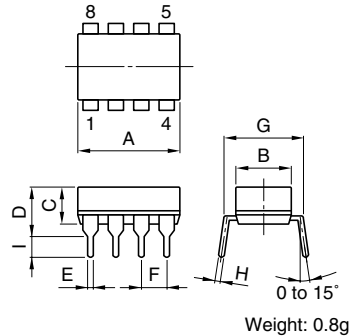

PLASTIC CASE

ZJY51R5-8PA-01

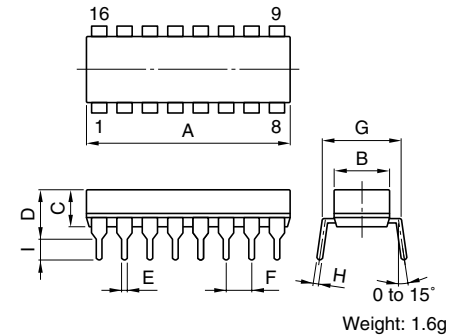

Part No.	Dimensions in mm									
	A max.	B max.	C max.	D max.	E	F±0.25	G	H	I	
ZJY51R5-2P-01, -2PB-01, -2PL-01*	5.5	6.86	4.57	5.84	0.5	2.54	7.62	0.25	2.54	
ZJY51R5-4P-01, -M4PA-01	10.5	6.86	4.57	5.84	0.5	2.54	7.62	0.25	2.54	
ZJY51R5-8PA-01	23.5	7	4.6	6.3	0.5	2.54	7.62	0.25	2.54	

* The ".01" designation at the end of the product code indicates Lead-free compatible product.

CIRCUIT DIAGRAMS

ZJY51R5-2P-01, -2PB-01, -2PL-01

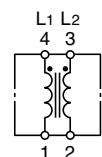

ZJY51R5-4P-01, -M4PA-01

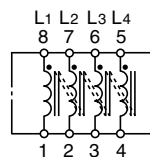

ZJY51R5-8PA-01

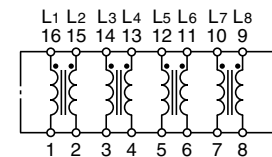

- Conformity to RoHS Directive: This means that, in conformity with EU Directive 2002/95/EC, lead, cadmium, mercury, hexavalent chromium, and specific bromine-based flame retardants, PBB and PBDE, have not been used, except for exempted applications.

- All specifications are subject to change without notice.

ELECTRICAL CHARACTERISTICS

Part No.	ZJY51R5-2P-01, -4P-01	ZJY51R5-2PB-01*1	ZJY51R5-2PL-01*2	ZJY51R5-M4PA-01	ZJY51R5-8PA-01
Rated voltage Edc(V)	50	50	50	50	50
Rated current (A)	2	2	2	0.5	0.5
Test voltage Edc(V) [Between terminals for 5s]	125	125	250	125	250
Insulation resistance (MΩ) [Between terminals at DC.50V for 1min]	100 min.	100 min.	100 min.	100 min.	100 min.
DC resistance (Ω) [Each line]	0.12 max.	0.12 max.	0.10 max.	0.25 max.	0.07 max.
Operating temperature range (°C)	-25 to +85	-25 to +85	-25 to +85	-25 to +85	-25 to +85
Storage temperature range(After mount)(°C)	-25 to +85	-25 to +85	-25 to +85	-25 to +85	-25 to +85
Impedance (Ω) [+5 to +35°C]	[20 to 300MHz]	[6 to 20MHz]	[20 to 100MHz]	[20 to 300MHz]	[20 to 300MHz]

*1 This type has improved low-range characteristics.

*2 This type is wrapped separately (for communication lines).

TYPICAL ELECTRICAL CHARACTERISTICS

IMPEDANCE CHARACTERISTICS (for 1 element)

ZJY51R5-2P-01, -4P-01, -8PA-01

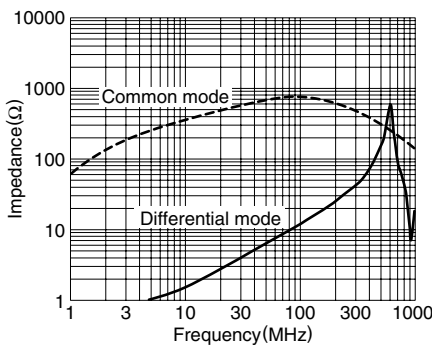

ZJY51R5-2PB-01

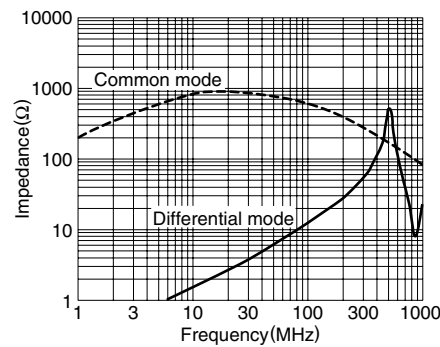

ZJY51R5-2PL-01

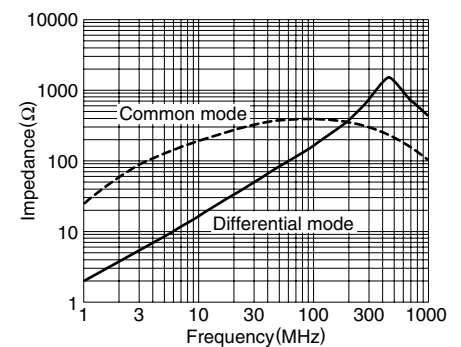

ZJY51R5-M4PA-01

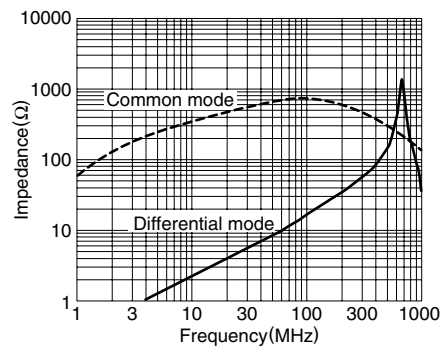

MEASURING CIRCUIT

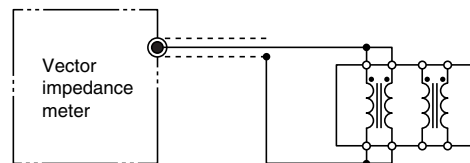

Vector impedance meter(YHP 4191A equivalent)
Measuring at each Common mode choke coil

TYPICAL APPLICATION

An application example showing how radiation noise is prevented when transmitter and receiver are connected via twisted pair cables.

