



Chipsmall Limited consists of a professional team with an average of over 10 year of expertise in the distribution of electronic components. Based in Hongkong, we have already established firm and mutual-benefit business relationships with customers from,Europe,America and south Asia,supplying obsolete and hard-to-find components to meet their specific needs.

With the principle of "Quality Parts,Customers Priority,Honest Operation,and Considerate Service",our business mainly focus on the distribution of electronic components. Line cards we deal with include Microchip,ALPS,ROHM,Xilinx,Pulse,ON,Everlight and Freescale. Main products comprise IC,Modules,Potentiometer,IC Socket,Relay,Connector.Our parts cover such applications as commercial,industrial, and automotives areas.

We are looking forward to setting up business relationship with you and hope to provide you with the best service and solution. Let us make a better world for our industry!



## Contact us

Tel: +86-755-8981 8866 Fax: +86-755-8427 6832

Email & Skype: info@chipsmall.com Web: www.chipsmall.com

Address: A1208, Overseas Decoration Building, #122 Zhenhua RD., Futian, Shenzhen, China



A full Design Manual is available to qualified customers. To register, please send an email to [TimingandSync@Zarlink.com](mailto:TimingandSync@Zarlink.com).

## Features

- Synchronizes with standard telecom system references and synthesizes a wide variety of protected telecom line interface clocks that are compliant with Telcordia GR-1244-CORE, GR-253-CORE, ITU-T G.813, and compatible with ITU-T G.8261 (formerly G.pactiming)
- Internal low jitter APLL provides SONET/SDH clocks including 6.48 MHz, 19.44 MHz, 38.88 MHz, 51.84 MHz and 77.76 MHz, or 25 MHz and 50 MHz Synchronous Ethernet output clocks
- Programmable output synthesizers (P0, P1) generate general purpose clock frequencies from any multiple of 8 kHz up to 100 MHz
- Jitter performance of <8 ps RMS on the low jitter APLL outputs, and <20 ps RMS on the programmable synthesizer outputs.
- Provides 8 reference inputs which support clock frequencies with any multiples of 8 kHz up to 77.76 MHz in addition to 2 kHz
- Provides two DLLs which have independent modes of operation (locked, free-run, holdover) and optional hitless reference switching.
- Flexible input reference monitoring automatically disqualifies references based on frequency and phase irregularities
- Provides 3 sync inputs for output frame pulse alignment
- Generates several styles of output frame pulses with selectable pulse width, polarity, and frequency
- Configurable input to output delay, and output to output phase alignment
- Supports IEEE 1149.1 JTAG Boundary Scan

## Ordering Information

ZL30120GGG	100 Pin CABGA	Trays
ZL30120GGG2	100 Pin CABGA**	Trays

\*\*Pb Free Tin/Silver/Copper

**-40°C to +85°C**

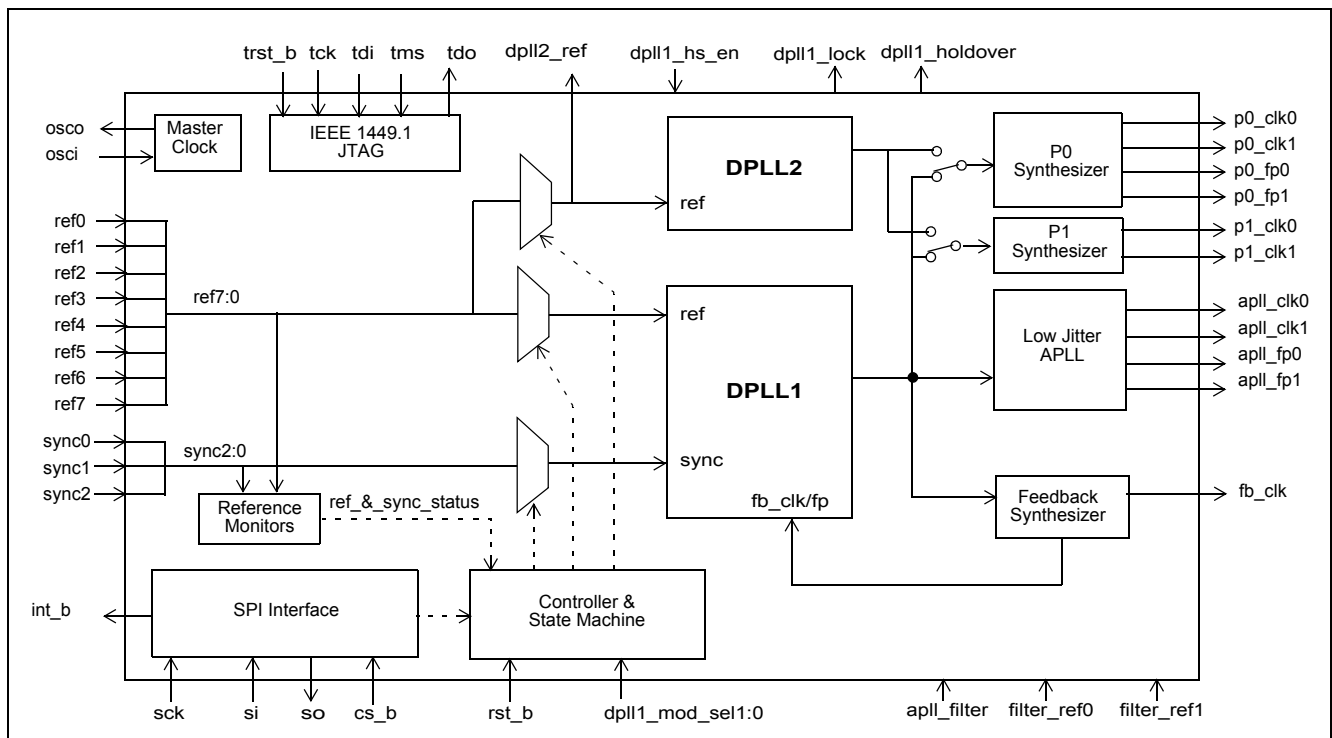

**Figure 1 - Block Diagram**

**Applications**

- AMCs for AdvancedTCA™ and MicroTCA Systems
- Synchronous Ethernet
- Multi-Service Edge Switches or Routers
- DSLAM Line Cards
- WAN Line Cards
- RNC/Mobile Switching Center Line Cards
- ADM Line Cards

---

## Table of Contents

<b>1.0 Functional Description</b> .....	<b>11</b>
1.1 DPLL Features .....	11
1.2 DPLL Mode Control .....	12
1.3 Ref and Sync Inputs .....	13
1.4 Ref and Sync Monitoring .....	14
1.5 Output Clocks and Frame Pulses .....	15
1.6 Configurable Input-to-Output and Output-to-Output Delays .....	17
<b>2.0 Software Configuration</b> .....	<b>18</b>
<b>3.0 References</b> .....	<b>25</b>

## List of Figures

Figure 1 - Block Diagram . . . . .	1
Figure 2 - Automatic Mode State Machine . . . . .	12
Figure 3 - Reference and Sync Inputs . . . . .	13
Figure 4 - Output Frame Pulse Alignment . . . . .	13
Figure 5 - Behaviour of the Guard Soak Timer during CFM or SCM Failures . . . . .	15
Figure 6 - Output Clock Configuration . . . . .	16
Figure 7 - Phase Delay Adjustments . . . . .	17

## List of Tables

Table 1 - DPLL1 and DPLL2 Features . . . . .	11
Table 2 - Set of Pre-Defined Auto-Detect Clock Frequencies . . . . .	14
Table 3 - Set of Pre-Defined Auto-Detect Sync Frequencies . . . . .	14
Table 4 - Output Clock and Frame Pulse Frequencies . . . . .	16

## Pin Description

Pin #	Name	I/O Type	Description
<b>Input Reference</b>			
C1 B2 A3 C3 B3 B4 C4 A4	ref0 ref1 ref2 ref3 ref4 ref5 ref6 ref7	I <sub>d</sub>	<b>Input References (LVCMOS, Schmitt Trigger).</b> These are input references available to both DPLL1 and DPLL2 for synchronizing output clocks. All eight input references can be automatically or manually selected using software registers. These pins are internally pulled down to V <sub>ss</sub> .
B1 A1 A2	sync0 sync1 sync2	I <sub>d</sub>	<b>Frame Pulse Synchronization References (LVCMOS, Schmitt Trigger).</b> These are the frame pulse synchronization inputs associated with input references 0, 1 and 2. These inputs accept frame pulses in a clock format (50% duty cycle) or a basic frame pulse format with minimum pulse width of 5 ns. These pins are internally pulled down to V <sub>ss</sub> .
<b>Output Clocks and Frame Pulses</b>			
D10	apll_clk0	O	<b>APLL Output Clock 0 (LVCMOS).</b> This output can be configured to provide any one of the available SONET/SDH clock outputs up to 77.76 MHz, or 25 MHz and 50 MHz. The default frequency for this output is 77.76 MHz.
G10	apll_clk1	O	<b>APLL Output Clock 1 (LVCMOS).</b> This output can be configured to provide any one of the available SONET/APLL clock outputs up to 77.76 MHz, or 25 MHz and 50 MHz. The default frequency for this output is 19.44 MHz.
E10	apll_fp0	O	<b>APLL Output Frame Pulse 0 (LVCMOS).</b> This output can be configured to provide virtually any style of output frame pulse synchronized with an associated APLL output clock. The default frequency for this frame pulse output is 8 kHz.
F10	apll_fp1	O	<b>APLL Output Frame Pulse 1 (LVCMOS).</b> This output can be configured to provide virtually any style of output frame pulse synchronized with an associated APLL output clock. The default frequency for this frame pulse output is 2 kHz.
K9	p0_clk0	O	<b>Programmable Synthesizer 0 - Output Clock 0 (LVCMOS).</b> This output can be configured to provide any frequency with a multiple of 8 kHz up to 100 MHz in addition to 2 kHz. The default frequency for this output is 2.048 MHz.
K7	p0_clk1	O	<b>Programmable Synthesizer 0 - Output Clock 1 (LVCMOS).</b> This is a programmable clock output configurable as a multiple or division of the p0_clk0 frequency within the range of 2 kHz to 100 MHz. The default frequency for this output is 8.192 MHz.
K8	p0_fp0	O	<b>Programmable Synthesizer 0 - Output Frame Pulse 0 (LVCMOS).</b> This output can be configured to provide virtually any style of output frame pulse associated with the p0 clocks. The default frequency for this frame pulse output is 8 kHz.
J7	p0_fp1	O	<b>Programmable Synthesizer 0 - Output Frame Pulse 1 (LVCMOS).</b> This output can be configured to provide virtually any style of output frame pulse associated with the p0 clocks. The default frequency for this frame pulse output is 8 kHz.

Pin #	Name	I/O Type	Description
J10	p1_clk0	O	<b>Programmable Synthesizer 1 - Output Clock 0 (LVCMOS).</b> This output can be configured to provide any frequency with a multiple of 8 kHz up to 100 MHz in addition to 2 kHz. The default frequency for this output is 1.544 MHz (DS1).
K10	p1_clk1	O	<b>Programmable Synthesizer1 - Output Clock 1 (LVCMOS).</b> This is a programmable clock output configurable as a multiple or division of the p1_clk0 frequency within the range of 2 kHz to 100 MHz. The default frequency for this output is 3.088 MHz (2x DS1).
H10	fb_clk	O	<b>Feedback Clock (LVCMOS).</b> This output is a buffered copy of the feedback clock for DPLL1. The frequency of this output always equals the frequency of the selected reference.
E1	dpll2_ref	O	<b>DPLL2 Selected Output Reference (LVCMOS).</b> This is a buffered copy of the output of the reference selector for DPLL2. Switching between input reference clocks at this output is not hitless.
<b>Control</b>			
H5	rst_b	I	<b>Reset (LVCMOS, Schmitt Trigger).</b> A logic low at this input resets the device. To ensure proper operation, the device must be reset after power-up. Reset should be asserted for a minimum of 300 ns.
J5	dpll1_hs_en	I <sub>U</sub>	<b>DPLL1 Hitless Switching Enable (LVCMOS, Schmitt Trigger).</b> A logic high at this input enables hitless reference switching. A logic low disables hitless reference switching and re-aligns DPLL1's output phase to the phase of the selected reference input. This feature can also be controlled through software registers. This pin is internally pulled up to Vdd.
C2 D2	dpll1_mod_sel0 dpll1_mod_sel1	I <sub>U</sub>	<b>DPLL1 Mode Select 1:0 (LVCMOS, Schmitt Trigger).</b> During reset, the levels on these pins determine the default mode of operation for DPLL1 (Automatic, Normal, Holdover or Freerun). After reset, the mode of operation can be controlled directly with these pins, or by accessing the <i>dpll1_modesel</i> register through the serial interface. This pin is internally pulled up to Vdd.
<b>Status</b>			
H1	dpll1_lock	O	<b>Lock Indicator (LVCMOS).</b> This is the lock indicator pin for DPLL1. This output goes high when DPLL1's output is frequency and phase locked to the input reference.
J1	dpll1_holdover	O	<b>Holdover Indicator (LVCMOS).</b> This pin goes high when DPLL1 enters the holdover mode.
<b>Serial Interface</b>			
E2	sck	I	<b>Clock for Serial Interface (LVCMOS).</b> Serial interface clock.
F1	si	I	<b>Serial Interface Input (LVCMOS).</b> Serial interface data input pin.
G1	so	O	<b>Serial Interface Output (LVCMOS).</b> Serial interface data output pin.
E3	cs_b	I <sub>U</sub>	<b>Chip Select for Serial Interface (LVCMOS).</b> Serial interface chip select. This pin is internally pulled up to Vdd.



Pin #	Name	I/O Type	Description
G2	int_b	O	<b>Interrupt Pin (LVCMOS).</b> Indicates a change of device status prompting the processor to read the enabled interrupt service registers (ISR). This pin is an open drain, active low and requires an external pulled up to VDD.
<b>APLL Loop Filter</b>			
A6	apll_filter	A	<b>External Analog PLL Loop Filter terminal.</b>
B6	filter_ref0	A	<b>Analog PLL External Loop Filter Reference.</b>
C6	filter_ref1	A	<b>Analog PLL External Loop Filter Reference.</b>
<b>JTAG and Test</b>			
J4	tdo	O	<b>Test Serial Data Out (Output).</b> JTAG serial data is output on this pin on the falling edge of tck. This pin is held in high impedance state when JTAG scan is not enabled.
K2	tdi	I <sub>u</sub>	<b>Test Serial Data In (Input).</b> JTAG serial test instructions and data are shifted in on this pin. This pin is internally pulled up to Vdd. If this pin is not used then it should be left unconnected.
H4	trst_b	I <sub>u</sub>	<b>Test Reset (LVCMOS).</b> Asynchronously initializes the JTAG TAP controller by putting it in the Test-Logic-Reset state. This pin should be pulsed low on power-up to ensure that the device is in the normal functional state. This pin is internally pulled up to Vdd. If this pin is not used then it should be connected to GND.
K3	tck	I	<b>Test Clock (LVCMOS):</b> Provides the clock to the JTAG test logic. If this pin is not used then it should be pulled down to GND.
J3	tms	I <sub>u</sub>	<b>Test Mode Select (LVCMOS).</b> JTAG signal that controls the state transitions of the TAP controller. This pin is internally pulled up to V <sub>DD</sub> . If this pin is not used then it should be left unconnected.
<b>Master Clock</b>			
K4	osci	I	<b>Oscillator Master Clock Input (LVCMOS).</b> This input accepts a 20 MHz reference from a clock oscillator (TCXO, OCXO). The stability and accuracy of the clock at this input determines the free-run accuracy and the long term holdover stability of the output clocks.
K5	osco	O	<b>Oscillator Master Clock Output (LVCMOS).</b> This pin must be left unconnected when the osci pin is connected to a clock oscillator.
<b>Miscellaneous</b>			
A9 A10 B5 B9 B10 C5 D1 D3 G3	NC		<b>No Connection.</b> Leave unconnected.

Pin #	Name	I/O Type	Description
J2 J6 H7 K1	IC		<b>Internal Connection.</b> Connect to ground.
F2 F3 K6	IC		<b>Internal Connection.</b> Leave unconnected.
<b>Power and Ground</b>			
D9 E4 G8 G9 J8 J9 H6 H8	$V_{DD}$	P P P P P P P P	<b>Positive Supply Voltage.</b> +3.3V <sub>DC</sub> nominal.
E8 F4	$V_{CORE}$	P P	<b>Positive Supply Voltage.</b> +1.8V <sub>DC</sub> nominal.
A5 A8 C10	$AV_{DD}$	P P P	<b>Positive Analog Supply Voltage.</b> +3.3V <sub>DC</sub> nominal.
B7 B8 H2	$AV_{CORE}$	P P P	<b>Positive Analog Supply Voltage.</b> +1.8V <sub>DC</sub> nominal.
D4 D5 D6 D7 E5 E6 E7 F5 F6 F7 G4 G5 G6 G7 E9 F8 F9 H9	$V_{SS}$	G G G G G G G G G G G G G G G G G G G	<b>Ground.</b> 0 Volts.

---

Pin #	Name	I/O Type	Description
A7 C7 C8 C9 D8 H3	$AV_{SS}$	G G G G G G	<b>Analog Ground. 0 Volts.</b>

I - Input  
 $I_d$  - Input, Internally pulled down  
 $I_u$  - Input, Internally pulled up  
O - Output  
A - Analog  
P - Power  
G - Ground

## 1.0 Functional Description

The ZL30120 Multi-Rate Line Card Synchronizer is a highly integrated device that provides timing and synchronization for network interface cards. It incorporates two independent DPLLs, each capable of locking to one of eight input references and provides a wide variety of synchronized output clocks and frame pulses.

### 1.1 DPLL Features

The ZL30120 provides two independently controlled Digital Phase-Locked Loops (DPLL1, DPLL2) for clock and/or frame pulse synchronization. DPLL1 is the main DPLL and is always enabled. To save on power, DPLL2 is disabled by default. For applications where DPLL2 is required, it must be enabled using the *dp1l\_en* bit of the *dp1l2\_ctrl\_0* register (0x2A). Table 1 shows a feature summary for both DPLLs.

Feature	DPLL1	DPLL2
Modes of Operation	Free-run, Normal (locked), Holdover	Free-run, Normal (locked), Holdover
Loop Bandwidth	User selectable: 14 Hz, 28 Hz, or wideband <sup>1</sup> (890 Hz / 56 Hz / 14 Hz)	Fixed: 14 Hz
Phase Slope Limiting	User selectable: 885 ns/s, 7.5 $\mu$ s/s, 61 $\mu$ s/s, or unlimited	User selectable: 61 $\mu$ s/s, or unlimited
Pull-in Range	Fixed: 130 ppm	Fixed: 130 ppm
Holdover Parameters	Selectable Update Times: 26 ms, 1 s, 10 s, 60 s, and Selectable Holdover Post Filter BW: 18 mHz, 2.5 Hz, 10 Hz.	Fixed Update Time: 26 ms No Holdover Post Filtering
Holdover Frequency Accuracy	Better than 1 ppb (Stratum 3E) initial frequency offset. Frequency drift depends on the 20 MHz external oscillator.	Better than 50 ppb (Stratum 3) initial frequency offset. Frequency drift depends on the 20 MHz external oscillator.
Reference Inputs	Ref0 to Ref7	Ref0 to Ref7
Sync Inputs	Sync0, Sync1, Sync2	Sync inputs are not supported.
Input Reference Selection/Switching	Automatic (based on programmable priority and revertiveness), or manual	Automatic (based on programmable priority and revertiveness), or manual
Hitless Ref Switching	Can be enabled or disabled	Can be enabled or disabled
Output Clocks	ap1l_clk0, ap1l_clk1, p0_clk0, p0_clk1, p1_clk0, p1_clk1, fb_clk.	p0_clk0, p0_clk1, p1_clk0, p1_clk1.
Output Frame Pulses	ap1l_fp0, ap1l_fp1, p0_fp0, p0_fp1 synchronized to active sync reference.	p0_fp0, p0_fp1 not synchronized to sync reference.
External Pins Status Indicators	Lock, Holdover	None

**Table 1 - DPLL1 and DPLL2 Features**

1. In the wideband mode, the loop bandwidth depends on the frequency of the reference input. For reference frequencies equal to or greater than 64 kHz, the loop bandwidth = 890 Hz. For reference frequencies equal to or greater than 8 kHz and less than 64 kHz, the loop bandwidth = 56 Hz. For reference frequencies equal to 2 kHz, the loop bandwidth is equal to 14 Hz.

## 1.2 DPLL Mode Control

Both DPLL1 and DPLL2 independently support three modes of operation - free-run, normal and holdover. The mode of operation can be manually set or controlled by an automatic state machine as shown in Figure 2.

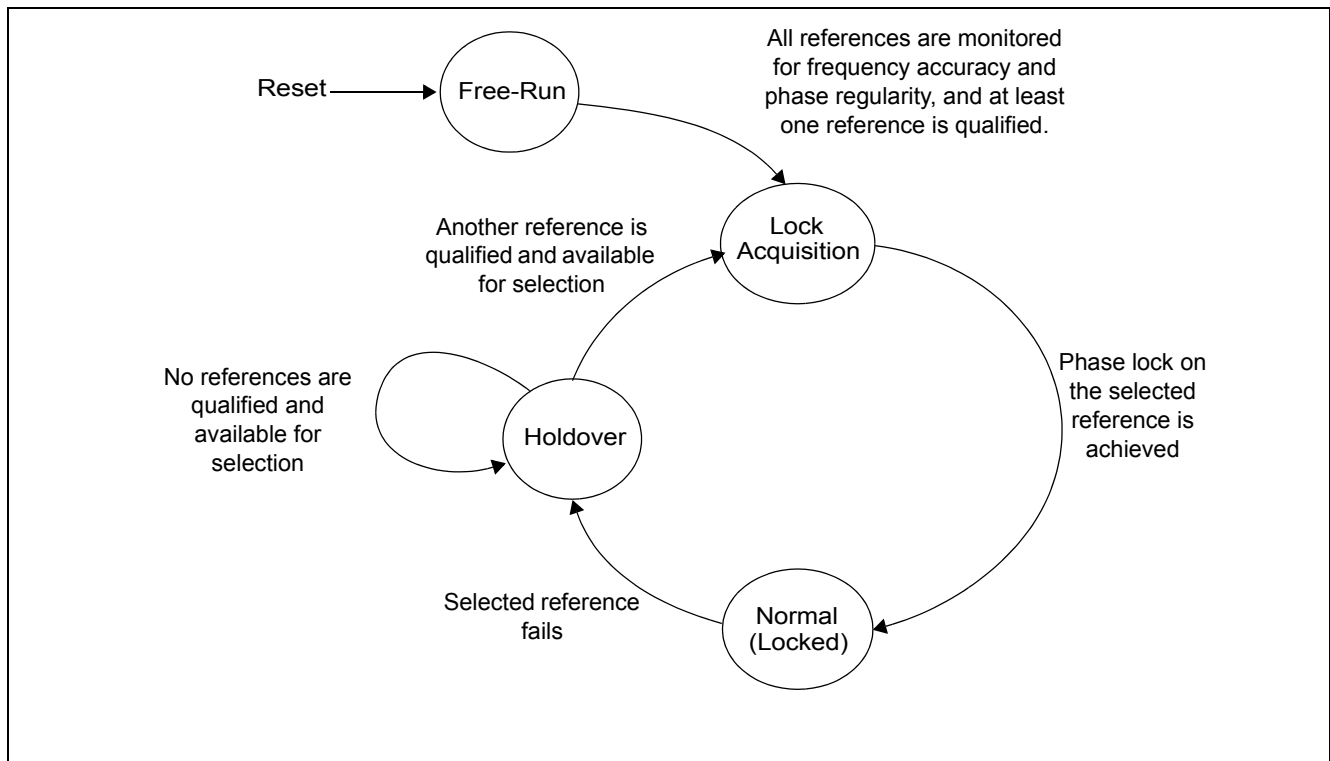

**Figure 2 - Automatic Mode State Machine**

### Free-run

The free-run mode occurs immediately after a reset cycle or when the DPLL has never been synchronized to a reference input. In this mode, the frequency accuracy of the output clocks is equal to the frequency accuracy of the external master oscillator.

### Lock Acquisition

The input references are continuously monitored for frequency accuracy and phase regularity. If at least one of the input references is qualified by the reference monitors, then the DPLL will begin lock acquisition on that input. Given a stable reference input, the ZL30120 will enter in the Normal (locked) mode.

### Normal (locked)

The usual mode of operation for the DPLL is the normal mode where the DPLL phase locks to a selected qualified reference input and generates output clocks and frame pulses with a frequency accuracy equal to the frequency accuracy of the reference input. While in the normal mode, the DPLL's clock and frame pulse outputs comply with the MTIE and TDEV wander generation specifications as described in Telcordia and ITU-T telecommunication standards.

### Holdover

When the DPLL operating in the normal mode loses its reference input, and no other qualified references are available, it will enter the holdover mode and continue to generate output clocks based on historical frequency data collected while the DPLL was synchronized.

### 1.3 Ref and Sync Inputs

There are eight reference clock inputs (**ref0** to **ref7**) available to both DPLL1 and DPLL2. The selected reference input is used to synchronize the output clocks. Each of the DPLLs have independent reference selectors which can be controlled using a built-in state machine or set in a manual mode.

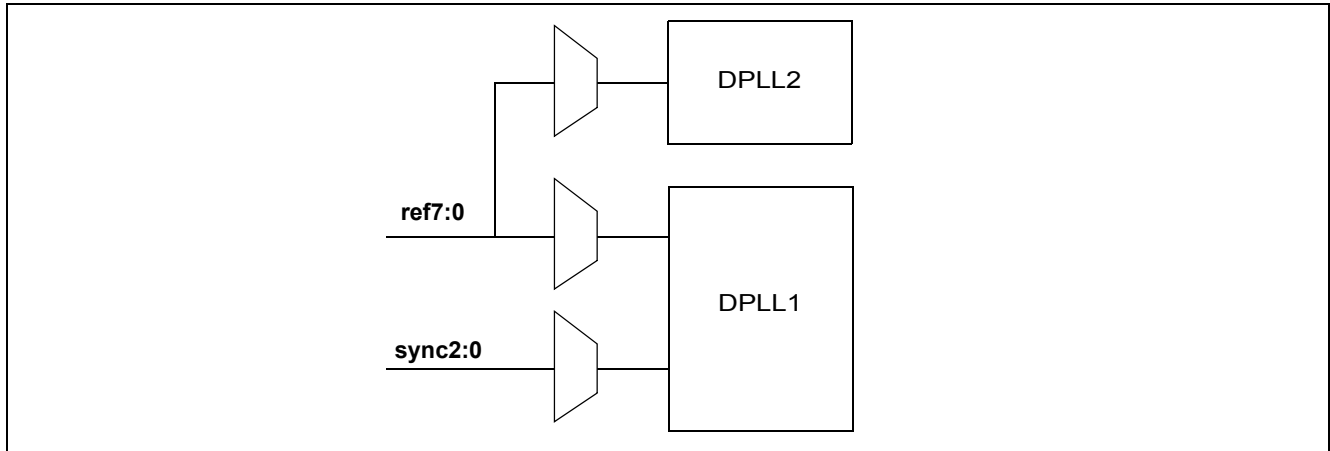

**Figure 3 - Reference and Sync Inputs**

In addition to the reference inputs, DPLL1 has three optional frame pulse synchronization inputs (**sync0** to **sync2**) used to align the output frame pulses. The  $sync_n$  input is selected with its corresponding  $ref_n$  input, where  $n = 0, 1,$  or  $2$ . Note that the sync input cannot be used to synchronize the DPLL, it only determines the alignment of the frame pulse outputs. An example of output frame pulse alignment is shown in Figure 4.

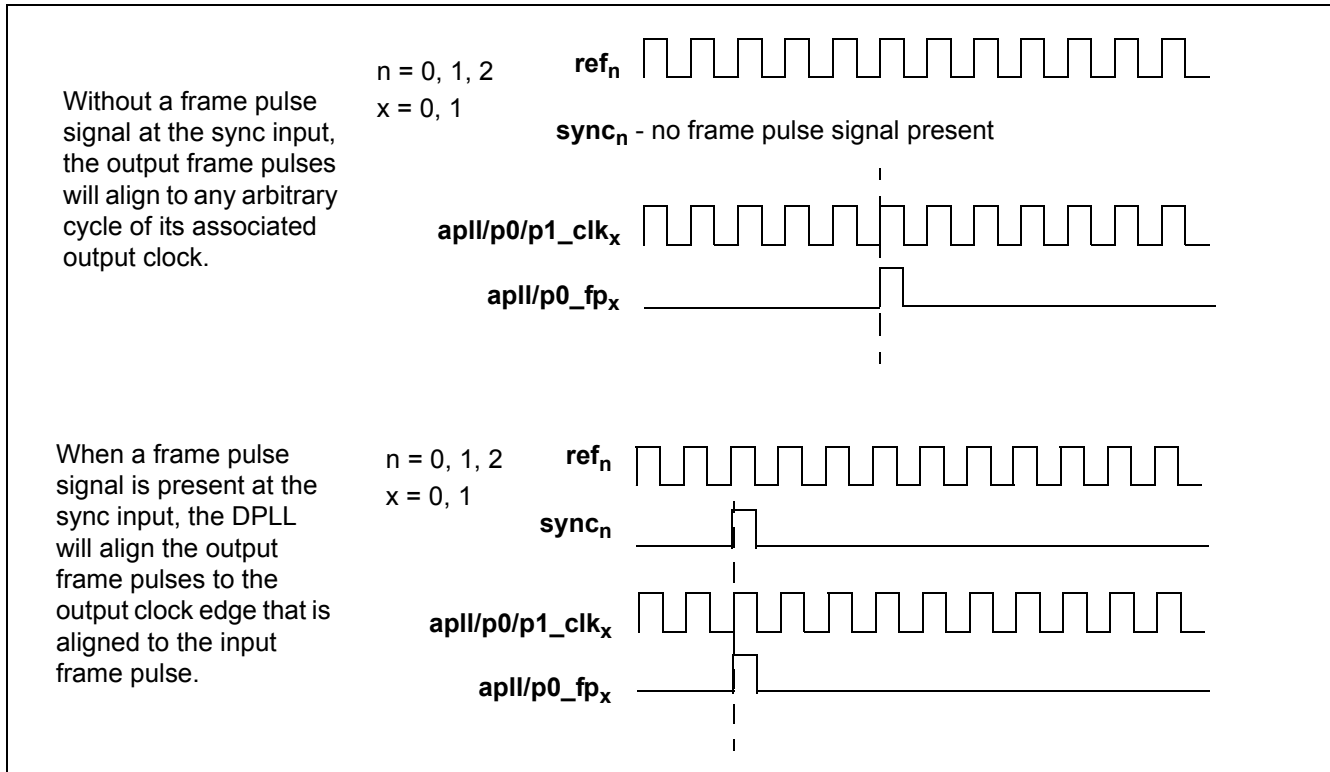

**Figure 4 - Output Frame Pulse Alignment**

Each of the **ref** inputs accept a single-ended LVCMOS clock with a frequency ranging from 2 kHz to 77.76 MHz. Built-in frequency detection circuitry automatically determines the frequency of the reference if its frequency is within the set of pre-defined frequencies as shown in Table 2. Custom frequencies definable in multiples of 8 kHz are also available.

2 kHz
8 kHz
64 kHz
1.544 MHz
2.048 MHz
6.48 MHz
8.192 MHz
16.384 MHz
19.44 MHz
38.88 MHz
77.76 MHz
Custom A
Custom B

**Table 2 - Set of Pre-Defined Auto-Detect Clock Frequencies**

Each of the **sync** inputs accept a single-ended LVCMOS frame pulse. Since alignment is determined from the rising edge of the frame pulse, there is no duty cycle restriction on this input, but there is a minimum pulse width requirement of 5 ns. Frequency detection for the sync inputs is automatic for the supported frame pulse frequencies shown in Table 3.

166.67 Hz (48x 125 $\mu$ s frames)
400 Hz
1 kHz
2 kHz
8 kHz
64 kHz

**Table 3 - Set of Pre-Defined Auto-Detect Sync Frequencies**

## 1.4 Ref and Sync Monitoring

All input references (**ref0** to **ref7**) are monitored for frequency accuracy and phase regularity. New references are qualified before they can be selected as a synchronization source, and qualified references are continuously monitored to ensure that they are suitable for synchronization. The process of qualifying a reference depends on four levels of monitoring.

### Single Cycle Monitor (SCM)

The SCM block measures the period of each reference clock cycle to detect phase irregularities or a missing clock edge. In general, if the measured period deviates by more than 50% from the nominal period, then an SCM failure (**scm\_fail**) is declared.

### Coarse Frequency Monitor (CFM)

The CFM block monitors the reference frequency over a measurement period of 30  $\mu$ s so that it can quickly detect large changes in frequency. A CFM failure (`cfm_fail`) is triggered when the frequency has changed by more than 3% or approximately 30000 ppm.

### Precise Frequency Monitor (PFM)

The PFM block measures the frequency accuracy of the reference over a 10 second interval. To ensure an accurate frequency measurement, the PFM measurement interval is re-initiated if phase or frequency irregularities are detected by the SCM or CFM. The PFM provides a level of hysteresis between the acceptance range and the rejection range to prevent a failure indication from toggling between valid and invalid for references that are on the edge of the acceptance range.

When determining the frequency accuracy of the reference input, the PFM uses the external oscillator's output frequency ( $f_{ocsi}$ ) as its point of reference.

### Guard Soak Timer (GST)

The GST block mimics the operation of an analog integrator by accumulating failure events from the CFM and the SCM blocks and applying a selectable rate of decay when no failures are detected.

As shown in Figure 5, a GST failure (`gst_fail`) is triggered when the accumulated failures have reached the upper threshold during the disqualification observation window. When there are no CFM or SCM failures, the accumulator decrements until it reaches its lower threshold during the qualification window.

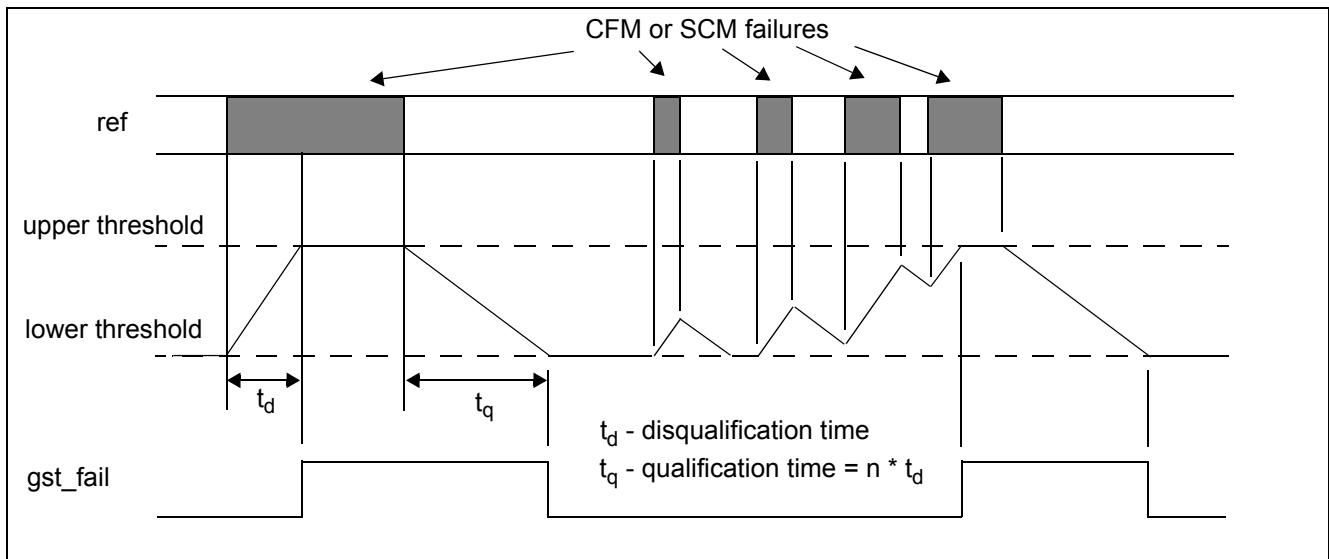

Figure 5 - Behaviour of the Guard Soak Timer during CFM or SCM Failures

All sync inputs (`sync0` to `sync2`) are continuously monitored to ensure that there is a correct number of reference clock cycles within the frame pulse period.

## 1.5 Output Clocks and Frame Pulses

The ZL30120 offers a wide variety of outputs including two low jitter LVCMOS (`apll_clk0`, `apll_clk1`) output clocks and four programmable LVCMOS (`p0_clk0`, `p0_clk1`, `p1_clk0`, `p1_clk1`) output clocks. In addition to the clock outputs, two LVCMOS frame pulse outputs (`apll_fp0`, `apll_fp1`) and two LVCMOS programmable frame pulses (`p0_fp0`, `p0_fp1`) are also available.

The feedback clock (`fb_clk`) of DPLL1 is available as an output clock. Its output frequency is always equal to DPLL1's selected input frequency.



The output clocks and frame pulses derived from the low jitter APLL are always synchronous with DPLL1, and the clocks and frame pulses generated from the programmable synthesizers can be synchronized to either DPLL1 or DPLL2. This allows the ZL30120 to have two independent timing paths.

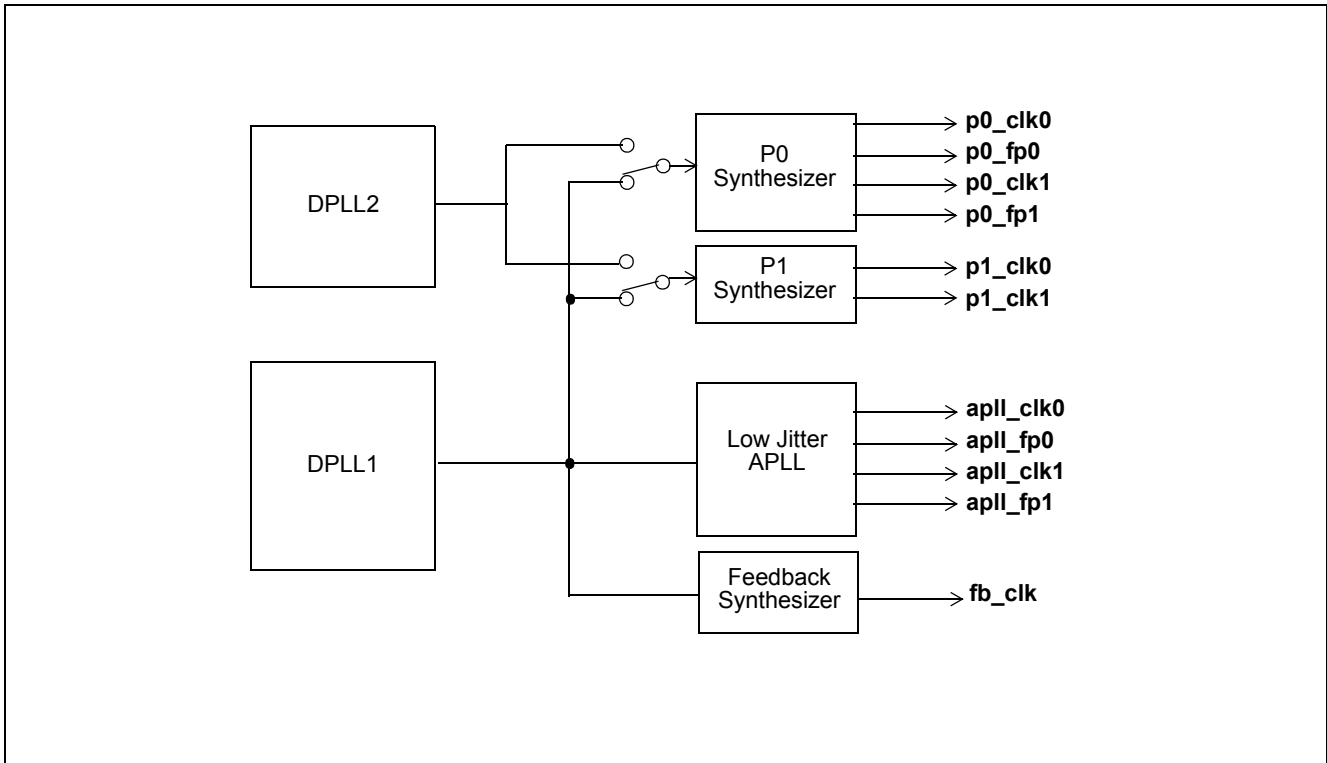

**Figure 6 - Output Clock Configuration**

The supported frequencies for the output clocks and frame pulses are shown in Table 4.

ap11_clk0, ap11_clk1 (LVCMOS) <sup>1</sup>	p0_clk0, p1_clk0 (LVCMOS)	p0_clk1, p1_clk1 (LVCMOS)	ap11_fp0, ap11_fp1, p0_fp0, p0_fp1 (LVCMOS) <sup>2</sup>
6.48 MHz	2 kHz	$p_x\_clk1 = \frac{p_x\_clk0}{2^M}$	166.67 Hz (48x 125 μs frames)
9.72 MHz	N * 8 kHz (up to 100 MHz)		400 Hz
12.96 MHz			1 kHz
19.44 MHz			2 kHz
25.92 MHz			4 kHz
38.88 MHz			8 kHz
51.84 MHz			32 kHz
77.76 MHz			64 kHz
25 MHz			
50 MHz			

**Table 4 - Output Clock and Frame Pulse Frequencies**

1. The ap11\_clk<sub>x</sub> outputs can generate either SONET/SDH or Ethernet frequencies (25 MHz, 50 MHz).
2. ap11\_fp<sub>x</sub> frequencies are available only when the low jitter ap11 is generating SONET/SDH frequencies

### 1.6 Configurable Input-to-Output and Output-to-Output Delays

The ZL30120 allows programmable static delay compensation for controlling input-to-output and output-to-output delays of its clocks and frame pulses.

All of the output synthesizers (APLL, P0, P1, Feedback) locked to DPLL1 can be configured to lead or lag the selected input reference clock using the **DPLL1 Fine Delay**. The delay is programmed in steps of 119.2 ps with a range of -128 to +127 steps giving a total delay adjustment in the range of -15.26 ns to +15.14 ns. Negative values delay the output clock, positive values advance the output clock. Synthesizers that are locked to DPLL2 are unaffected by this delay adjustment.

In addition to the fine delay introduced in the DPLL1 path, the APLL, P0, and P1 synthesizers have the ability to add their own fine delay adjustments using the **P0 Fine Delay**, **P1 Fine Delay**, and **APLL Fine Delay**. These delays are also programmable in steps of 119.2 ps with a range of -128 to +127 steps.

In addition to these delays, the single-ended output clocks of the APLL, P0, and P1 synthesizers can be independently offset by 90, 180 and 270 degrees using the **Coarse Delay**. The output frame pulses (APLL, P0) can be independently offset with respect to each other using the **FP Delay**.

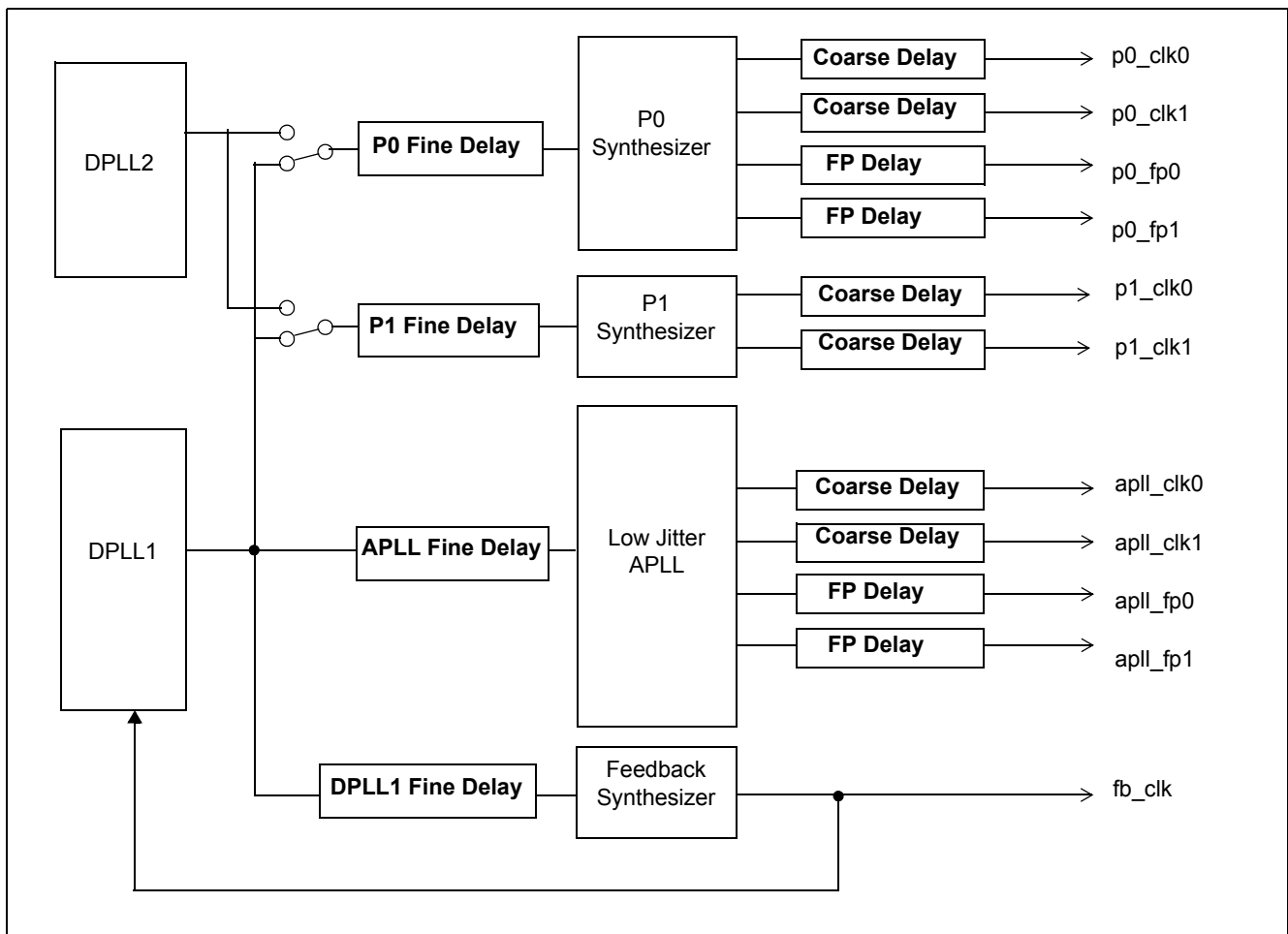

Figure 7 - Phase Delay Adjustments

## 2.0 Software Configuration

The ZL30120 is mainly controlled by accessing software registers through the serial peripheral interface (SPI). The device can be configured to operate in a highly automated manner which minimizes its interaction with the system's processor, or it can operate in a manual mode where the system processor controls most of the operation of the device.

The following table provides a summary of the registers available for status updates and configuration of the device.

Addr (Hex)	Register Name	Reset Value (Hex)	Description	Type
<b>Miscellaneous Registers</b>				
00	id_reg	A4	Chip and version identification and reset ready indication register	R
01	use_hw_ctrl	00	Allows some functions of the device to be controlled by hardware pins	R/W
<b>Interrupts</b>				
02	ref_fail_isr	FF	Reference failure interrupt service register	R
03	dpll1_isr	70	DPLL1 interrupt service register	Sticky R
04	dpll2_isr	00	DPLL2 interrupt service register	Sticky R
05	ref_mon_fail_0	FF	Ref0 and ref1 failure indications	Sticky R
06	ref_mon_fail_1	FF	Ref2 and ref3 failure indications.	Sticky R
07	ref_mon_fail_2	FF	Ref4 and ref5 failure indications	Sticky R
08	ref_mon_fail_3	FF	Ref6 and ref7 failure indications	Sticky R
09	ref_fail_isr_mask	00	Reference failure interrupt service register mask	R/W
0A	dpll1_isr_mask	00	DPLL1 interrupt service register mask	R/W
0B	dpll2_isr_mask	00	DPLL2 interrupt service register mask	R/W
0C	ref_mon_fail_mask_0	FF	Control register to mask each failure indicator for ref0 and ref1	R/W
0D	ref_mon_fail_mask_1	FF	Control register to mask each failure indicator for ref2 and ref3	R/W
0E	ref_mon_fail_mask_2	FF	Control register to mask each failure indicator for ref4 and ref5	R/W

Addr (Hex)	Register Name	Reset Value (Hex)	Description	Type
0F	ref_mon_fail_mask_3	FF	Control register to mask each failure indicator for ref6 and ref7	R/W
<b>Reference Monitor Setup</b>				
10	detected_ref_0	FF	Ref0 and ref1 auto-detected frequency value status register	R
11	detected_ref_1	FF	Ref2 and ref3 auto-detected frequency value status register	R
12	detected_ref_2	FF	Ref4 and ref5 auto-detected frequency value status register	R
13	detected_ref_3	FF	Ref6 and ref7 auto-detected frequency value status register	R
14	detected_sync_0	EE	Sync0 and sync1 auto-detected frequency value and sync failure status register	R
15	detected_sync_1	0E	Sync2 auto-detected frequency value and sync valid status register	R
16	oor_ctrl_0	33	Control register for the ref0 and ref1 out of range limit	R/W
17	oor_ctrl_1	33	Control register for the ref2 and ref3 out of range limit	R/W
18	oor_ctrl_2	33	Control register for the ref4 and ref5 out of range limit	R/W
19	oor_ctrl_3	33	Control register for the ref6 and ref7 out of range limit	R/W
1A	gst_mask_0	FF	Control register to mask the inputs to the guard soak timer for ref0 to ref3	R/W
1B	gst_mask_1	FF	Control register to mask the inputs to the guard soak timer for ref4 to ref7	R/W
1C	gst_qualif_time	1A	Control register for the guard_soak_timer qualification time and disqualification time for the references	R/W
<b>DPLL1 Control</b>				
1D	dpll1_ctrl_0	See Register Description	Control register for the DPLL1 filter control; phase slope limit, bandwidth and hitless switching	R/W
1E	dpll1_ctrl_1	See Register Description	Holdover update time, filter_out_en, freq_offset_en, revert enable	R/W

Addr (Hex)	Register Name	Reset Value (Hex)	Description	Type
1F	dpll1_modesel	See Register Description	Control register for the DPLL1 mode of operation	R/W
20	dpll1_refsel	00	DPLL1 reference selection or reference selection status	R/W
21	dpll1_ref_fail_mask	3C	Control register to mask each failure indicator (SCM, CFM, PFM and GST) used for automatic reference switching and automatic holdover	R/W
22	dpll1_wait_to_restore	00	Control register to indicate the time to restore a previous failed reference	R/W
23	dpll1_ref_rev_ctrl	00	Control register for the ref0 to ref7 enable revertive signals	R/W
24	dpll1_ref_pri_ctrl_0	10	Control register for the ref0 and ref1 priority values	R/W
25	dpll1_ref_pri_ctrl_1	32	Control register for the ref2 and ref3 priority values	R/W
26	dpll1_ref_pri_ctrl_2	54	Control register for the ref4 and re5 priority values	R/W
27	dpll1_ref_pri_ctrl_3	76	Control register for the ref6 and ref7 priority values	R/W
28	dpll1_lock_holdover_status	04	DPLL1 lock and holdover status register	R
29	dpll1_pullinrange	03	Control register for the pull-in range	R/W
<b>DPLL2 Control</b>				
2A	dpll2_ctrl_0	00	Control register to program the DPLL2: hitless switching, the phase slope limit and DPLL enable	R/W
2B	dpll2_ctrl_1	04	Control register to program the DPLL2: filter_out_en, freq_offset_en, revert enable	R/W
2C	dpll2_modesel	02	Control register to select the mode of operation of the DPLL2	R/W
2D	dpll2_refsel	00	DPLL2 reference selection or reference selection status	R/W
2E	dpll2_ref_fail_mask	3C	Control register to mask each failure indicator (SCM, CFM, PFM and GST) used for automatic reference switching and automatic holdover	R/W
2F	dpll2_wait_to_restore	00	Control register to indicate the time to restore a previous failed reference for the DPLL2 path	R/W

Addr (Hex)	Register Name	Reset Value (Hex)	Description	Type
30	dpll2_ref_rev_ctrl	00	Control register for the ref0 to ref7 enable revertive signals	R/W
31	dpll2_ref_pri_ctrl_0	10	Control register for the ref0 and ref1 priority values	R/W
32	dpll2_ref_pri_ctrl_1	32	Control register for the ref2 and ref3 priority values	R/W
33	dpll2_ref_pri_ctrl_2	54	Control register for the ref4 and re5 priority values	R/W
34	dpll2_ref_pri_ctrl_3	76	Control register for the ref6 and ref7 priority values	R/W
35	dpll2_lock_holdover_status	04	DPLL2 lock and holdover status register	R
<b>P0 Configuration Registers</b>				
36	p0_enable	8F	Control register to enable p0_clk0, p0_clk1, p0_fp0, p0_fp1, the P0 synthesizer and select the source	R/W
37	p0_run	0F	Control register to generate p0_clk0, p0_clk1, p0_fp0 and p0_fp1	R/W
38	p0_freq_0	00	Control register for the [7:0] bits of the N of N*8k clk0	R/W
39	p0_freq_1	01	Control register for the [13:8] bits of the N of N*8k clk0	R/W
3A	p0_clk0_offset90	00	Control register for the p0_clk0 phase position coarse tuning	R/W
3B	p0_clk1_div	3E	Control register for the p0_clk1 frequency selection	R/W
3C	p0_clk1_offset90	00	Control register for the p0_clk1 phase position coarse tuning	R/W
3D	p0_offset_fine	00	Control register for the output/output phase alignment fine tuning for p0 path	R/W
3E	p0_fp0_freq	05	Control register to select the p0_fp0 frame pulse frequency	R/W
3F	p0_fp0_type	83	Control register to select fp0 type	R/W
40	p0_fp0_offset_0	00	Bits [7:0] of the programmable frame pulse phase offset in multiples of 1/262.14 MHz	R/W
41	p0_fp0_offset_1	00	Bits [15:8] of the programmable frame pulse phase offset in multiples of 1/262.14 MHz	R/W

Addr (Hex)	Register Name	Reset Value (Hex)	Description	Type
42	p0_fp0_offset_2	00	Bits [21:16] of the programmable frame pulse phase offset in multiples of 8 kHz cycles	R/W
43	p0_fp1_freq	05	Control register to select p0_fp1 frame pulse frequency	R/W
44	p0_fp1_type	11	Control register to select fp1 type	R/W
45	p0_fp1_offset_0	00	Bits [7:0] of the programmable frame pulse phase offset in multiples of 1/262.144 MHz	R/W
46	p0_fp1_offset_1	00	Bits [15:8] of the programmable frame pulse phase offset in multiples of 1/262.144 MHz	R/W
47	p0_fp1_offset_2	00	Bits [21:16] of the programmable frame pulse phase offset in multiples of 8 kHz cycles	R/W
<b>P1 Configuration Registers</b>				
48	p1_enable	83	Control register to enable p1_clk0, p1_clk1, the P1 synthesizer and select the source	R/W
49	p1_run	03	Control register to generate enable/disable p1_clk0 and p1_clk1	R/W
4A	p1_freq_0	C1	Control register for the [7:0] bits of the N of N*8k clk0	R/W
4B	p1_freq_1	00	Control register for the [13:8] bits of the N of N*8k clk0	R/W
4C	p1_clk0_offset90	00	Control register for the p1_clk0 phase position coarse tuning	R/W
4D	p1_clk1_div	3F	Control register for the p1_clk1 frequency selection	R/W
4E	p1_clk1_offset90	00	Control register for the p1_clk1 phase position coarse tuning	R/W
4F	p1_offset_fine	00	Control register for the output/output phase alignment fine tuning	R/W
<b>APLL Configuration Registers</b>				
50	apll_enable	8F	Control register to enable apll_clk0, apll_clk1, apll_fp0, apll_fp1 and the APLL	R/W
51	apll_run	0F	Control register to generate apll_clk0, apll_clk1, apll_fp0 and apll_fp1	R/W
52	apll_clk_div	42	Control register for the apll_clk0 and apll_clk1 frequency selection	R/W
53	apll_clk0_offset90	00	Control register for the apll_clk0 phase position coarse tuning	R/W

Addr (Hex)	Register Name	Reset Value (Hex)	Description	Type
54	apll_clk1_offset90	00	Control register for the apll_clk1 phase position coarse tuning	R/W
55	apll_offset_fine	00	Control register for the output/output phase alignment fine tuning for apll path	R/W
56	apll_fp0_freq	05	Control register to select the apll_fp0 frame pulse frequency	R/W
57	apll_fp0_type	23	Control register to select fp0 type	R/W
58	apll_fp0_offset_0	00	Bits [7:0] of the programmable frame pulse phase offset in multiples of 1/311.04 MHz	R/W
59	apll_fp0_offset_1	00	Bits [15:8] of the programmable frame pulse phase offset in multiples of 1/311.04 MHz	R/W
5A	apll_fp0_offset_2	00	Bits [21:16] of the programmable frame pulse phase offset in multiples of 8 kHz cycles	R/W
5B	apll_fp1_freq	03	Control register to select apll_fp1 frame pulse frequency	R/W
5C	apll_fp1_type	03	Control register to select fp1 type	R/W
5D	apll_fp1_offset_0	00	Bits [7:0] of the programmable frame pulse phase offset in multiples of 1/311.04 MHz	R/W
5E	apll_fp1_offset_1	00	Bits [15:8] of the programmable frame pulse phase offset in multiples of 1/311.04 MHz	R/W
5F	apll_fp1_offset_2	00	Bits [21:16] of the programmable frame pulse phase offset in multiples of 8 kHz cycles	R/W
60	reserved	A3	Leave as default	R/W
61	reserved	53	Leave as default	R/W
<b>External Feedback Configuration</b>				
62	fb_control	81	Control register to enable fb_clk and the FB PLL, int/ext feedback select	R/W
63	fb_offset_fine	F5	Control register for the output/output phase alignment fine tuning	R/W
64	reserved			
<b>N * 8 kHz Reference Control</b>				
65	ref_freq_mode_0	00	Control register to set whether to use auto detect, CustomA or CustomB for ref0 to ref3	R/W
66	ref_freq_mode_1	00	Control register to set whether to use auto detect, CustomA or CustomB for ref4 to ref7	R/W



Addr (Hex)	Register Name	Reset Value (Hex)	Description	Type
67	custA_mult_0	00	Control register for the [7:0] bits of the custom configuration A. This is the N integer for the N*8kHz reference monitoring.	R/W
68	custA_mult_1	00	Control register for the [13:8] bits of the custom configuration A. This is the N integer for the N*8kHz reference monitoring.	R/W
69	custA_scm_low	00	Control register for the custom configuration A: single cycle SCM low limiter	R/W
6A	custA_scm_high	00	Control register for the custom configuration A: single cycle SCM high limiter	R/W
6B	custA_cfm_low_0	00	Control register for the custom configuration A: The [7:0] bits of the single cycle CFM low limit	R/W
6C	custA_cfm_low_1	00	Control register for the custom configuration A: The [15:0] bits of the single cycle CFM low limit	R/W
6D	custA_cfm_hi_0	00	Control register for the custom configuration A: The [7:0] bits of the single cycle CFM high limit	R/W
6E	custA_cfm_hi_1	00	Control register for the custom configuration A: The [15:0] bits of the single cycle CFM high limiter	R/W
6F	custA_cfm_cycle	00	Control register for the custom configuration A: CFM reference monitoring cycles - 1	R/W
70	custA_div	00	Control register for the custom configuration A: enable the use of ref_div4 for the CFM and PFM inputs	R/W
71	custB_mult_0	00	Control register for the [7:0] bits of the custom configuration B. This is the 8 k integer for the N*8kHz reference monitoring.	R/W
72	custB_mult_1	00	Control register for the [13:8] bits of the custom configuration B. This is the 8 k integer for the N*8kHz reference monitoring.	R/W
73	custB_scm_low	00	Control register for the custom configuration B: single cycle SCM low limiter	R/W
74	custB_scm_high	00	Control register for the custom configuration B: single cycle SCM high limiter	R/W
75	custB_cfm_low_0	00	Control register for the custom configuration B: The [7:0] bits of the single cycle CFM low limiter.	R/W

Addr (Hex)	Register Name	Reset Value (Hex)	Description	Type
76	custB_cfm_low_1	00	Control register for the custom configuration B: The [15:0] bits of the single cycle CFM low limiter.	R/W
77	custB_cfm_hi_0	00	Control register for the custom configuration B: The [7:0] bits of the single cycle CFM high limiter.	R/W
78	custB_cfm_hi_1	00	Control register for the custom configuration B: The [15:0] bits of the single cycle CFM high limiter.	R/W
79	custB_cfm_cycle	00	Control register for the custom configuration B: CFM reference monitoring cycles - 1	R/W
7A	custB_div	00	Control register for the custom configuration B: enable the use of ref_div4 for the CFM and PFM inputs	R/W
7B - 7F	Reserved			

### 3.0 References

AdvancedTCA, ATCA and the AdvancedTCA and ATCA logos are trademarks of the PCI Industrial Computer Manufacturers Group.

This datasheet provides a summary of the high level features of the ZL30120. Refer to the ZL30120 Design Manual for a more complete description.