



Chipsmall Limited consists of a professional team with an average of over 10 year of expertise in the distribution of electronic components. Based in Hongkong, we have already established firm and mutual-benefit business relationships with customers from,Europe,America and south Asia,supplying obsolete and hard-to-find components to meet their specific needs.

With the principle of “Quality Parts,Customers Priority,Honest Operation,and Considerate Service”,our business mainly focus on the distribution of electronic components. Line cards we deal with include Microchip,ALPS,ROHM,Xilinx,Pulse,ON,Everlight and Freescale. Main products comprise IC,Modules,Potentiometer,IC Socket,Relay,Connector.Our parts cover such applications as commercial,industrial, and automotives areas.

We are looking forward to setting up business relationship with you and hope to provide you with the best service and solution. Let us make a better world for our industry!



Contact us

Tel: +86-755-8981 8866 Fax: +86-755-8427 6832

Email & Skype: info@chipsmall.com Web: www.chipsmall.com

Address: A1208, Overseas Decoration Building, #122 Zhenhua RD., Futian, Shenzhen, China



Features

Inputs/Outputs

- Accepts two differential or single-ended inputs
 - LVPECL, LVDS, CML, HCSL, LVCMOS
 - Glitch-free switching of references
- On-chip input termination resistors and biasing for AC coupled inputs
- Eight precision LVPECL outputs
- Operating frequency up to 750 MHz

Power

- Options for 2.5 V or 3.3 V power supply
- Core current consumption of 122 mA
- On-chip Low Drop Out (LDO) Regulator for superior power supply rejection

Performance

- Ultra low additive jitter of 106 fs RMS

Ordering Information

ZL40211LDG1	32 Pin QFN	Trays
ZL40211LDF1	32 Pin QFN	Tape and Reel
Matte Tin		
Package size: 5 x 5 mm		
-40°C to +85°C		

Applications

- General purpose clock distribution
- Low jitter clock trees
- Logic translation
- Clock and data signal restoration
- Redundant clock distribution
- Wired communications: OTN, SONET/SDH, GE, 10 GE, FC and 10G FC
- Wireless communications
- High performance microprocessor clock distribution

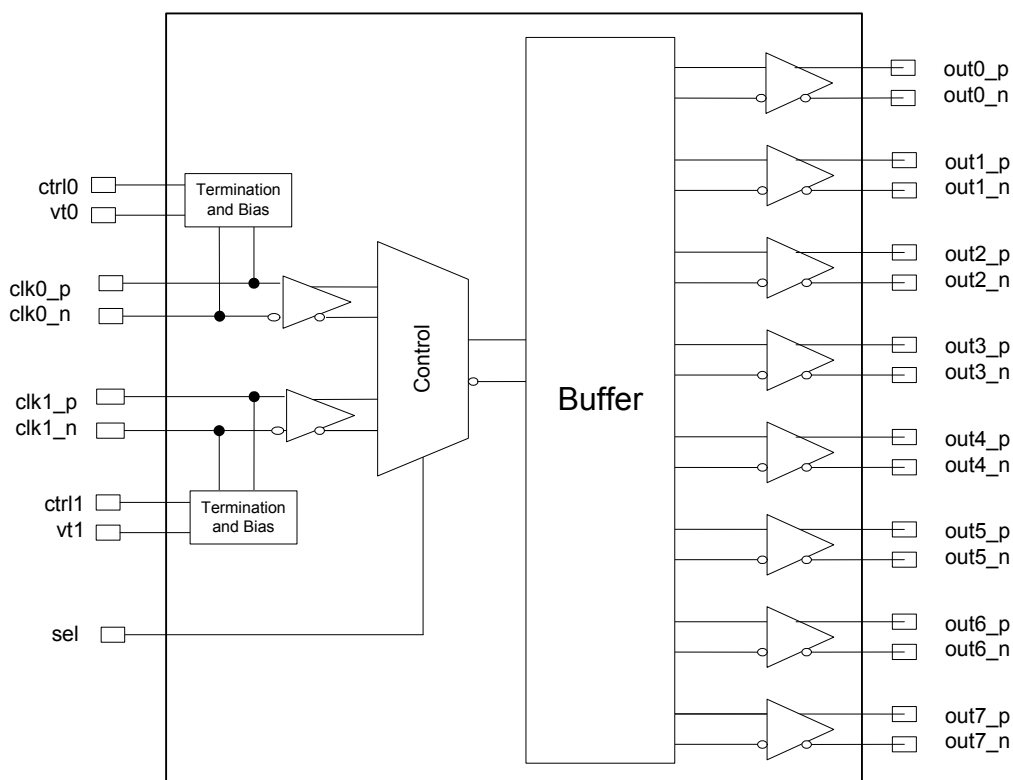

Figure 1 - Functional Block Diagram

Table of Contents

Features	1
Inputs/Outputs	1
Power	1
Performance	1
Applications	1
1.0 Package Description	4
2.0 Pin Description	5
3.0 Functional Description	6
3.1 Clock Inputs	6
3.2 Clock Input Selection	6
3.2.1 Clock Input Terminations	7
3.3 Clock Outputs	12
3.4 Device Additive Jitter	15
3.5 Power Supply	16
3.5.1 Sensitivity to power supply noise	16
3.5.2 Power supply filtering	16
3.5.3 PCB layout considerations	16
4.0 Electrical Characteristics	17
5.0 Performance Characterization	20
6.0 Typical Behavior	21
7.0 Package Characteristics	23
8.0 Mechanical Drawing	24

List of Figures

Figure 1 - Functional Block Diagram	1
Figure 2 - Pin Connections	4
Figure 3 - Simplified Diagram of input stage	6
Figure 4 - Output During Clock Switch - Both Clocks Running	7
Figure 5 - Clock Input - LVPECL - DC Coupled	7
Figure 6 - Clock Input - LVPECL - AC Coupled	8
Figure 7 - Clock Input - LVDS - DC Coupled	8
Figure 8 - Clock Input - LVDS - AC Coupled	9
Figure 9 - Clock Input - CML- AC Coupled	9
Figure 10 - Clock Input - HCSL- AC Coupled	10
Figure 11 - Clock Input - AC-coupled Single-Ended	10
Figure 12 - Clock Input - DC-coupled 3.3V CMOS	11
Figure 13 - Simplified Output Driver.	12
Figure 14 - LVPECL Basic Output Termination	12
Figure 15 - LVPECL Parallel Output Termination.	13
Figure 16 - LVPECL Parallel Thevenin-Equivalent Output Termination.	13
Figure 17 - LVPECL AC Output Termination	14
Figure 18 - LVPECL AC Output Termination for CML Inputs	14
Figure 19 - Additive Jitter.	15
Figure 20 - Decoupling Connections for Power Pins	16
Figure 21 - Output Differential Voltage Parameter.	18
Figure 22 - Input To Output Timing	19

Change Summary

Below are the changes from the November 2012 issue to the February 2013 issue:

Page	Item	Change
7	Figure 5	Changed text to indicate the circuit is not recommended for VDD_driver=2.5V.

1.0 Package Description

The device is packaged in a 32 pin QFN

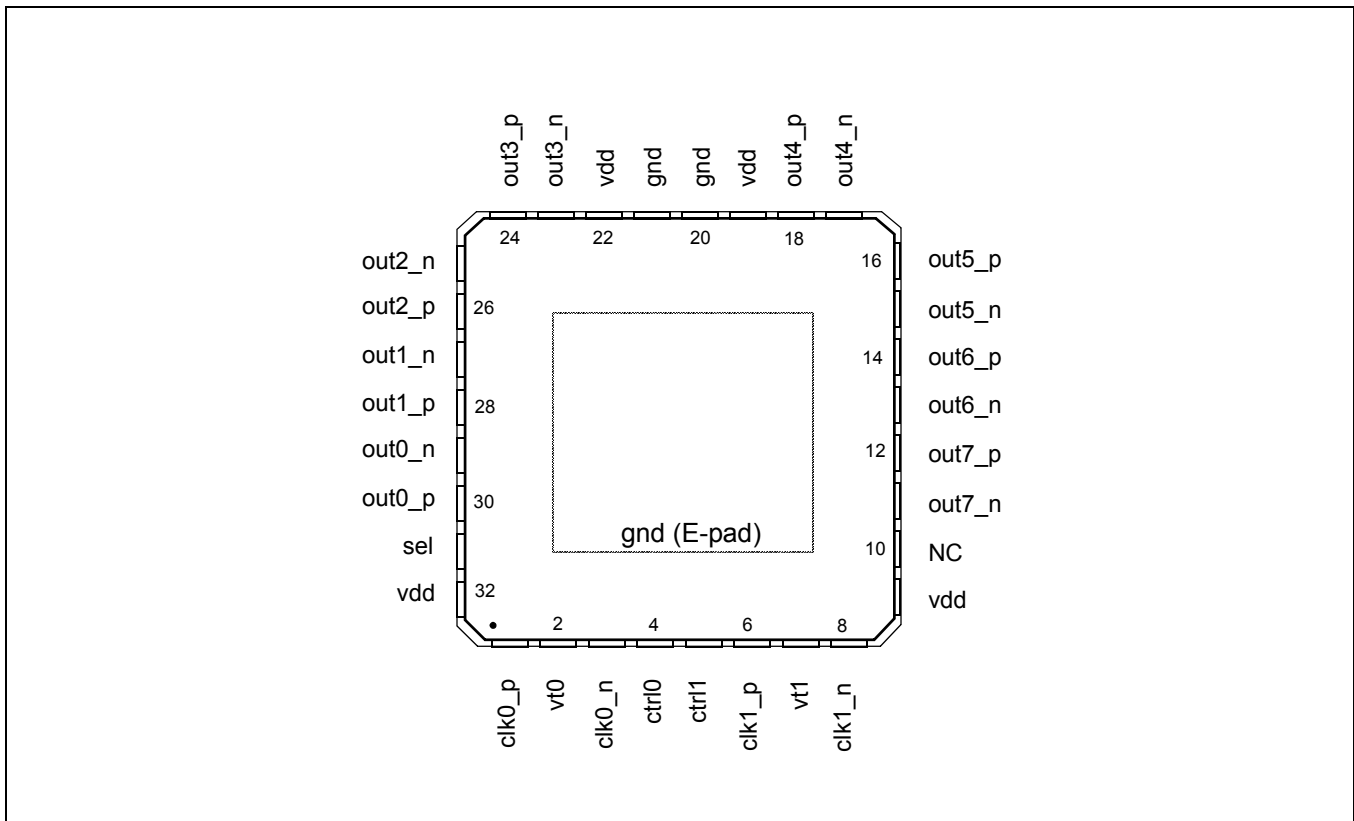

Figure 2 - Pin Connections

2.0 Pin Description

Pin Description

Pin #	Name	Description
1,3, 6, 8	clk0_p, clk0_n, clk1_p, clk1_n	Differential Input (Analog Input). Differential input signals.
30, 29, 28, 27, 26, 25, 24, 23, 18, 17, 16, 15, 14, 13, 12, 11	out0_p, out0_n out1_p, out1_n out2_p, out2_n out3_p, out3_n out4_p, out4_n out5_p, out5_n out6_p, out6_n out7_p, out7_n	Differential Output (Analog Output). Differential outputs.
9, 19, 22, 32	vdd	Positive Supply Voltage. 2.5V _{DC} or 3.3 V _{DC} nominal.
20, 21	gnd	Ground. 0 V.
2, 7	vt0, vt1	On-Chip Input Termination Node (Analog). Center tap between internal 50 Ohm termination resistors. For a DC coupled LVPECL input connect this pin through a resistor to ground; 50 Ohms for 3.3V LVPECL or 20 Ohms for 2.5V LVPECL. For a DC coupled LVDS input or for an AC coupled differential input, leave this pin unconnected.
4, 5	ctrl0, ctrl1	Digital Control for On-Chip Input Termination (Input). Selects differential input mode; 0: DC coupled LVPECL or LVDS modes 1: AC coupled differential modes These pins are internally pulled down to GND.
10	NC	No Connection. Leave unconnected.
31	sel	Input Select (Input). Selects the reference input that is buffered; 0: clk0 1: clk1 This pin is internally pulled down to GND.

3.0 Functional Description

The ZL40211 is an LVPECL clock fan out buffer with two input and eight output clock drivers capable of operating at frequencies up to 750MHz.

The ZL40211 provides an internal input termination network for DC and AC coupled inputs; optional input biasing for AC coupled inputs is also provided. The ZL40211 can accept DC or AC coupled LVPECL and LVDS input signals, AC coupled CML or HCSL input signals, and single ended signals. A pin compatible device with external termination is also available.

The ZL40211 is designed to fan out low-jitter reference clocks for wired or optical communications applications while adding minimal jitter to the clock signal. An internal linear power supply regulator and bulk capacitors minimize additive jitter due to power supply noise. The device operates from 2.5V \pm 5% or 3.3V \pm 5% supply. Its operation is guaranteed over the industrial temperature range -40°C to +85°C.

The device block diagram is shown in Figure 1; its operation is described in the following sections.

3.1 Clock Inputs

The device has a differential input equipped with two on-chip 50 Ohm termination resistors arranged in series with a center tap. The input can accept many differential and single-ended signals with AC or DC coupling as appropriate. A control pin is available to enable internal biasing for AC coupled inputs. A block diagram of the input stage is in Figure 3.

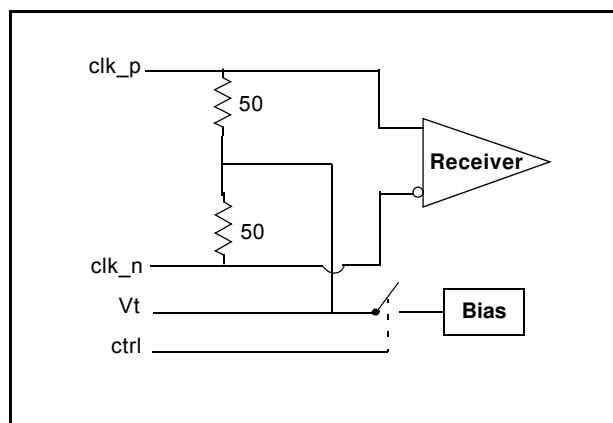

Figure 3 - Simplified Diagram of Input Stage

3.2 Clock Input Selection

The select line chooses which input clock is routed to the outputs.

Sel	Active Input
0	clk0
1	clk1

Table 1 - Input Selection

The following figure shows the expected clock switching performance. The output stops at the first falling edge of the initial clock after the select pin changes state. During switching there will be a short time when the output clock is not toggling. After this delay, the output will start toggling again with a rising edge of the newly selected clock.

This behavior is independent of the frequencies of the input clocks. For instance, the two clocks could be at different frequencies and the behavior would still be consistent with this figure.

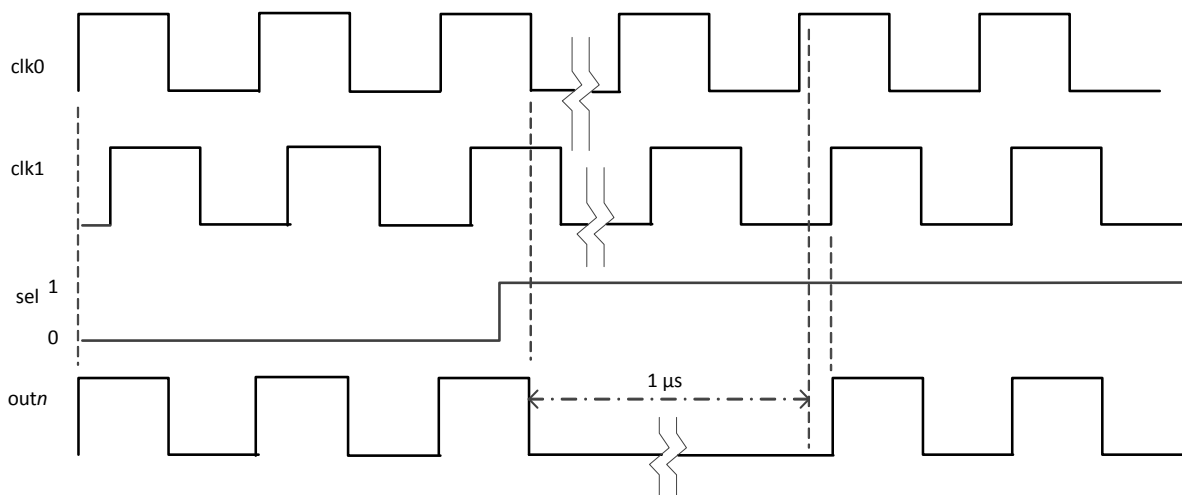

Figure 4 - Output During Clock Switch - Both Clocks Running

3.2.1 Clock Input Terminations

The following figures show how to connect various input clock types to the fanout buffer. Each diagram shows how to configure the *Vt* and *ctrl* pins along with the other necessary components and their values.

For input clock types where the *ctrl* pin is "1" and the *Vt* pin is not connected, the *Vt* pin can be instead connected to V_{DD} with a capacitor.

In addition, a capacitor can also help in Figure 5 between *Vt* and V_{DD} . This capacitor will minimize the noise at the point between the two internal termination resistors and improve the overall performance of the device.

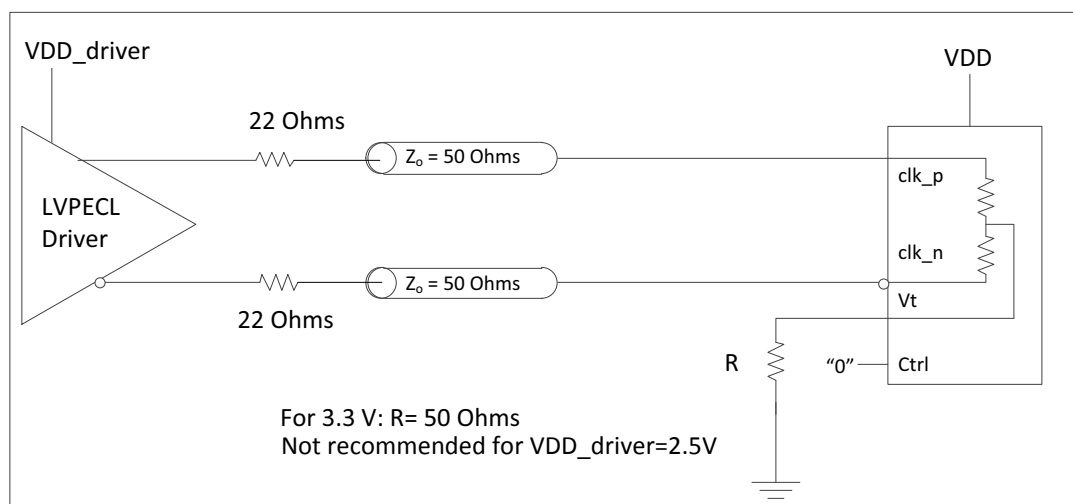

Figure 5 - Clock Input - LVPECL - DC Coupled

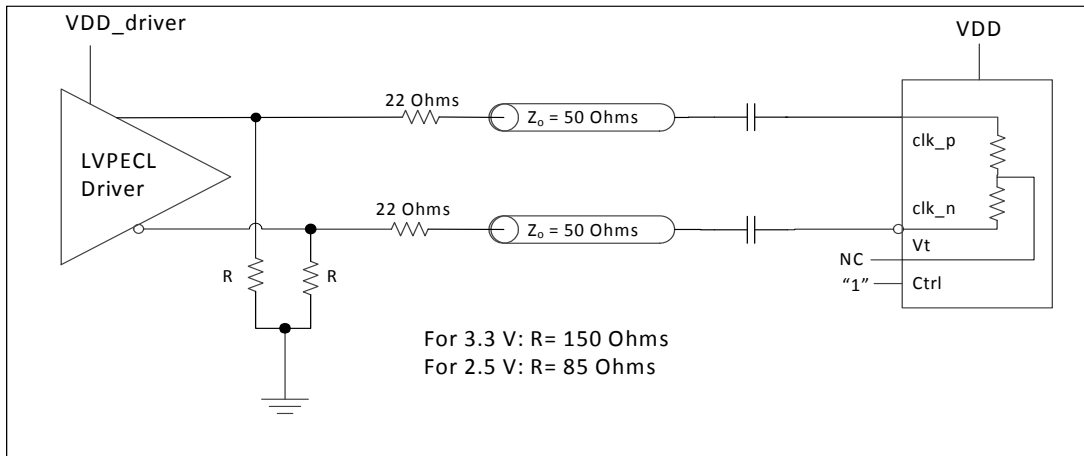

Figure 6 - Clock Input - LVPECL - AC Coupled

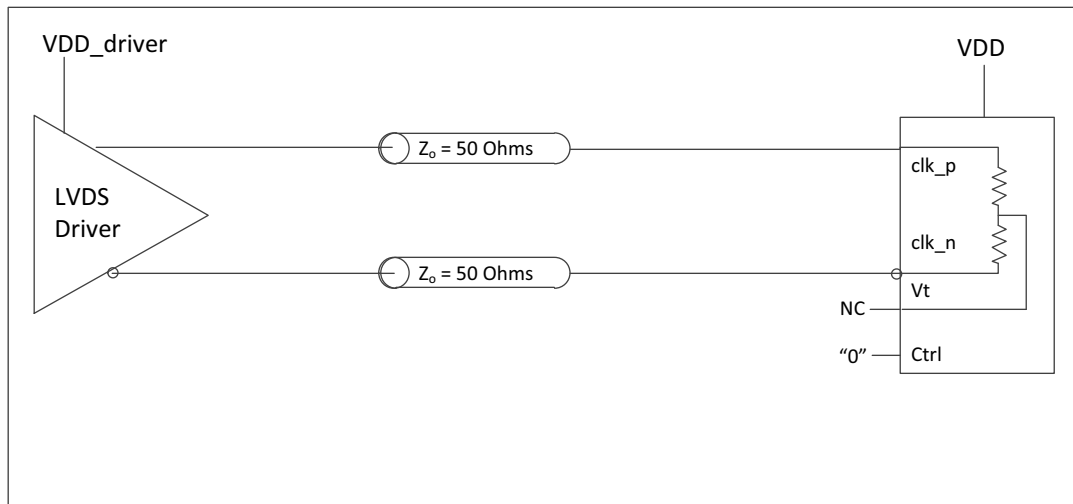

Figure 7 - Clock Input - LVDS - DC Coupled

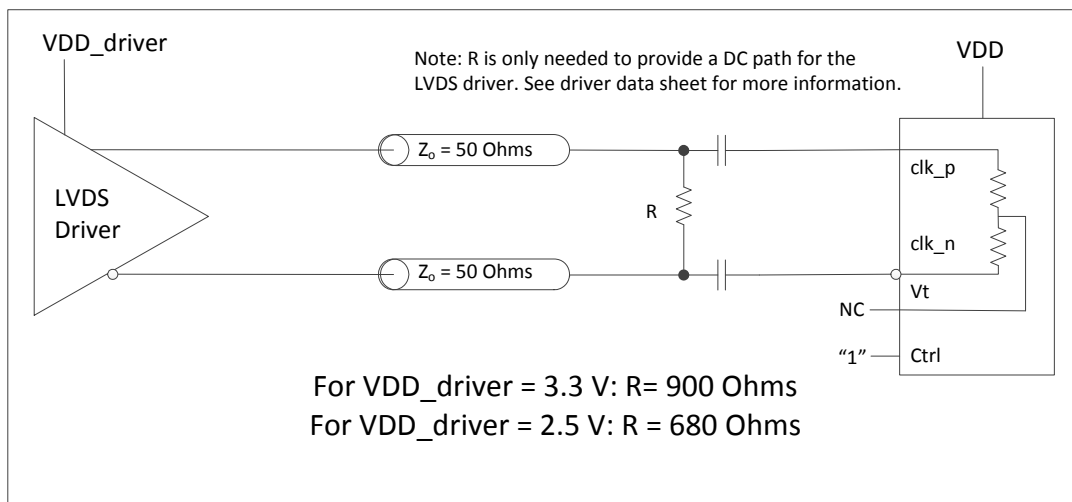

Figure 8 - Clock Input - LVDS - AC Coupled

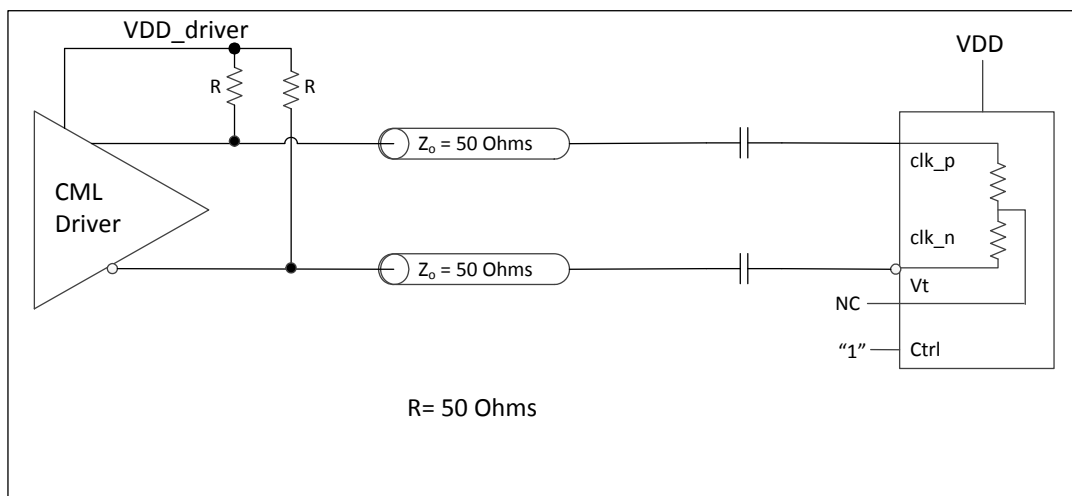

Figure 9 - Clock Input - CML- AC Coupled

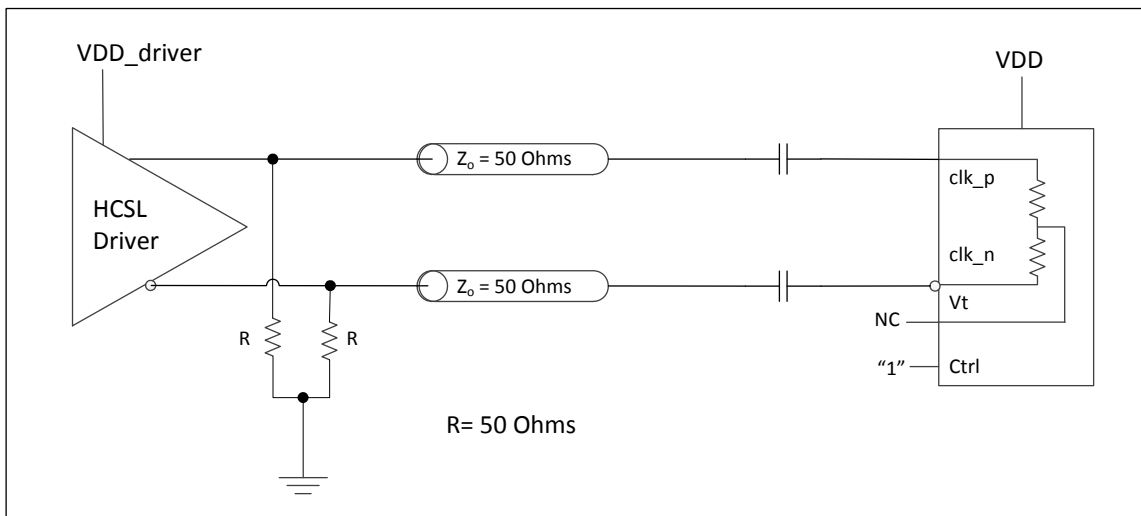

Figure 10 - Clock Input - HCSL- AC Coupled

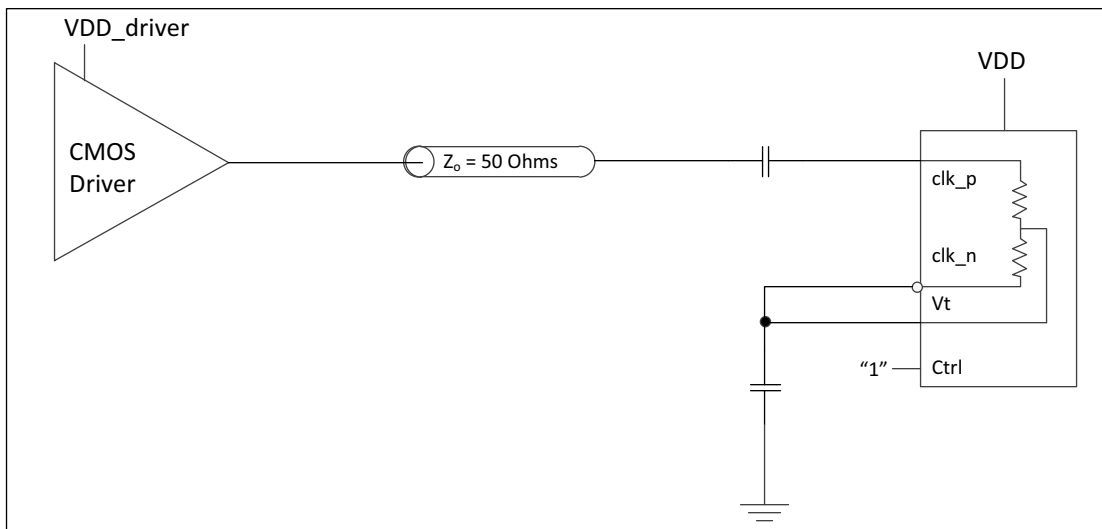

Figure 11 - Clock Input - AC-coupled Single-Ended

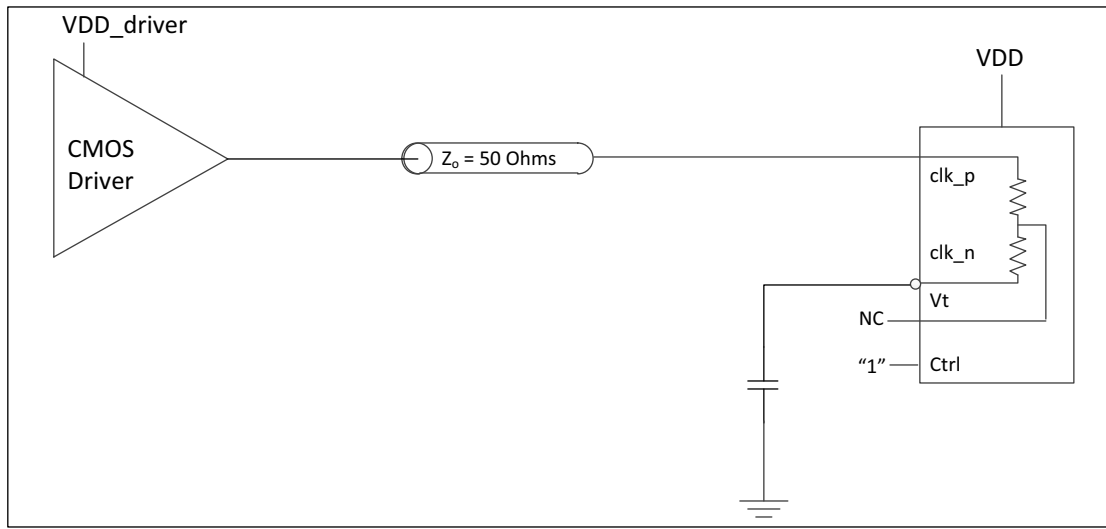

Figure 12 - Clock Input - DC-coupled 3.3V CMOS

3.3 Clock Outputs

LVPECL has a very low output impedance and a differential signal swing between 1 V and 1.6 V. A simplified diagram for the output stage is shown in Figure 13. The LVPECL to LVDS output termination is not shown since there is a different device with the same inputs and LVDS outputs.

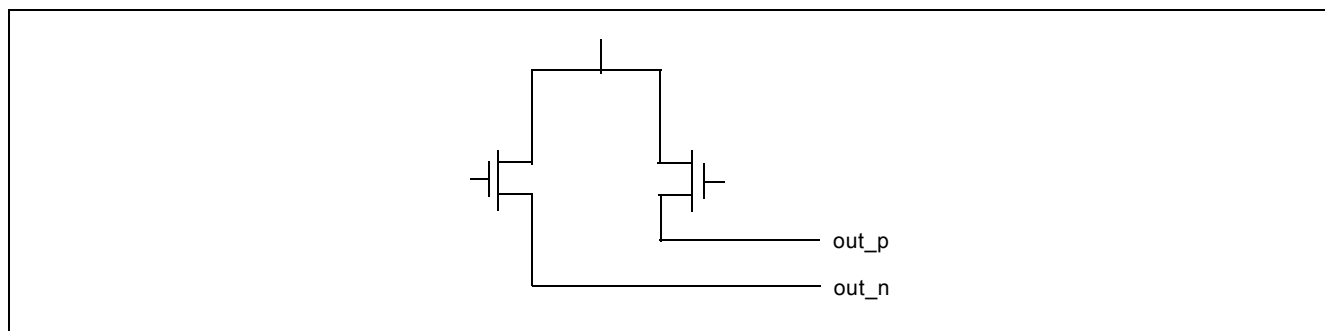

Figure 13 - Simplified Output Driver

The methods to terminate the ZL40211 LVPECL drivers are shown in the following figures.

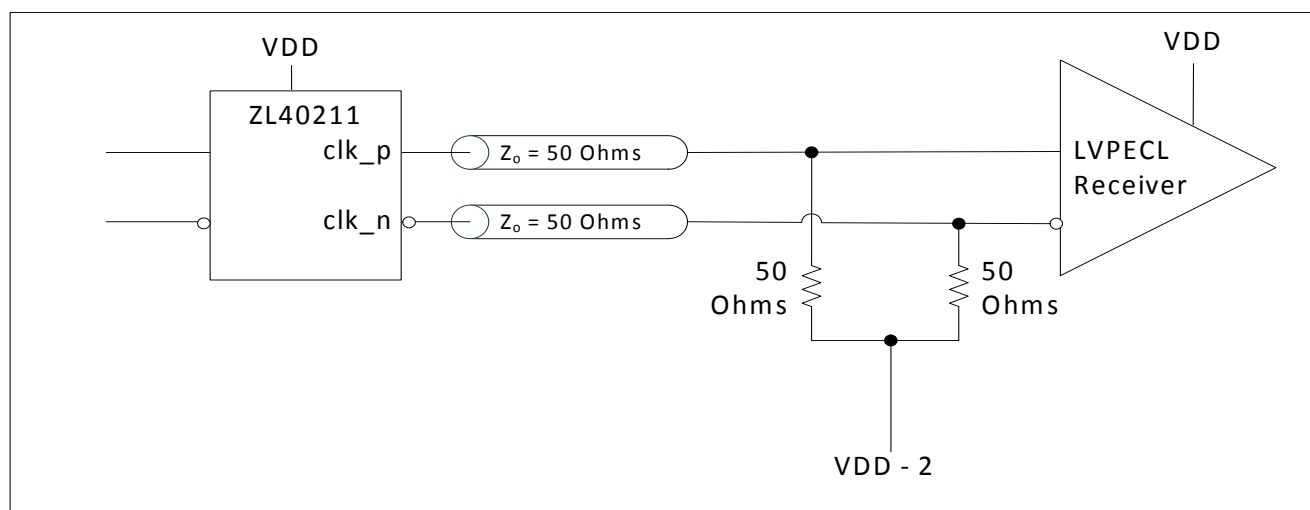

Figure 14 - LVPECL Basic Output Termination

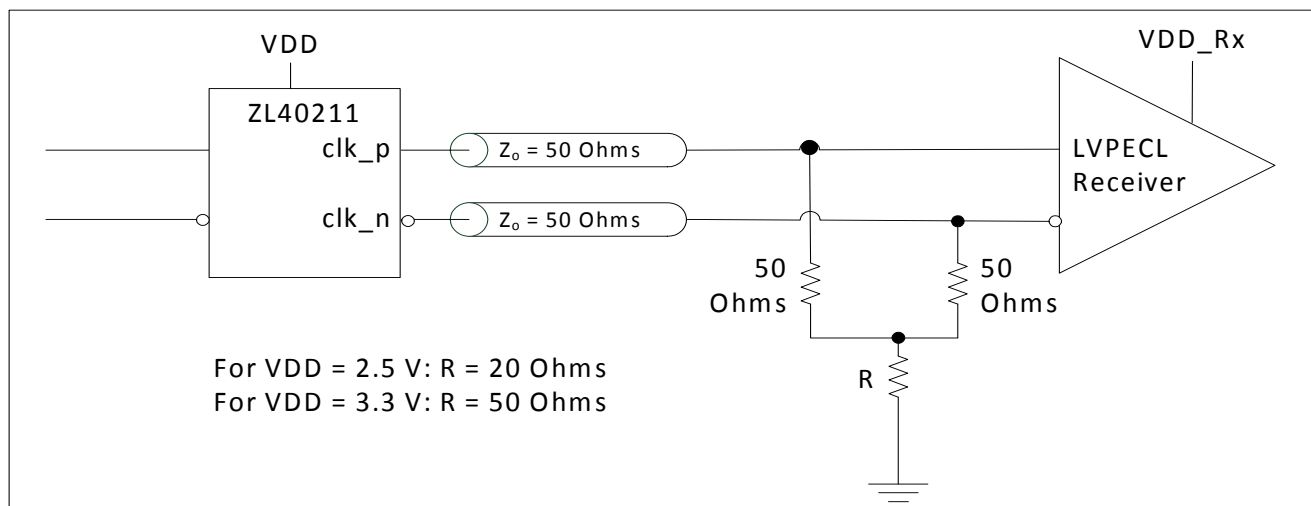

Figure 15 - LVPECL Parallel Output Termination

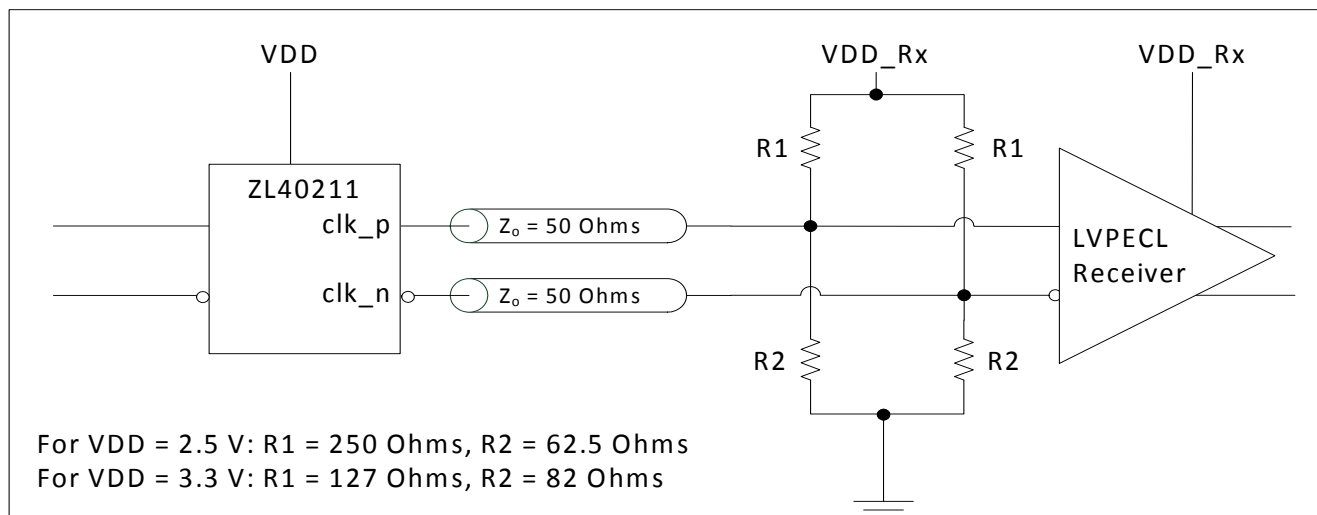

Figure 16 - LVPECL Parallel Thevenin-Equivalent Output Termination

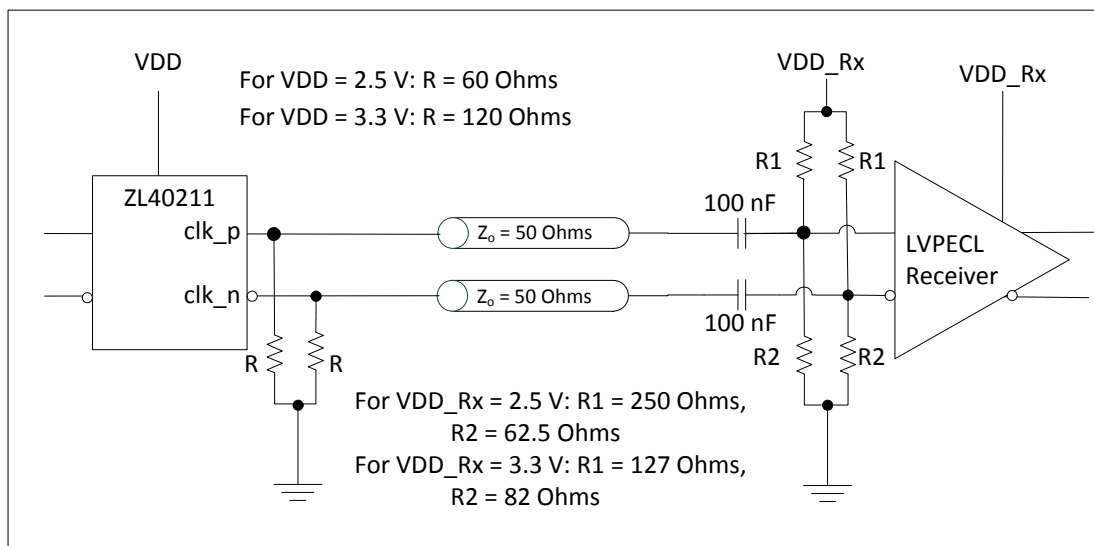

Figure 17 - LVPECL AC Output Termination

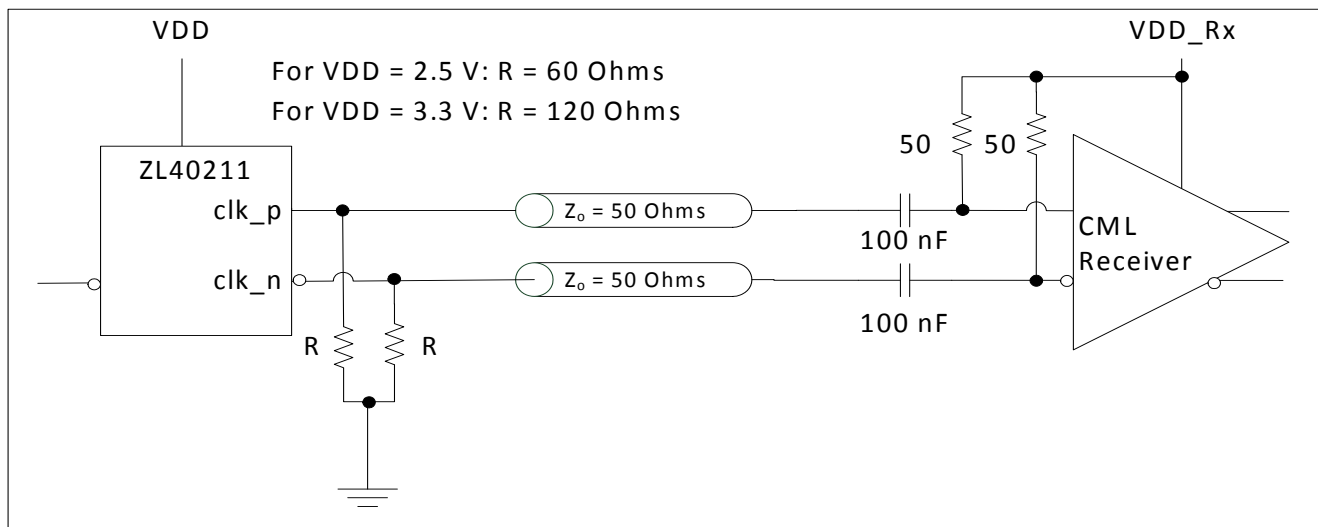

Figure 18 - LVPECL AC Output Termination for CML Inputs

3.4 Device Additive Jitter

The ZL40211 clock fanout buffer is not intended to filter clock jitter. The jitter performance of this type of device is characterized by its additive jitter. Additive jitter is the jitter the device would add to a hypothetical jitter-free clock as it passes through the device. The additive jitter of the ZL40211 is random and as such it is not correlated to the jitter of the input clock signal.

The square of the resultant random RMS jitter at the output of the ZL40211 is equal to the sum of the squares of the various random RMS jitter sources including: input clock jitter; additive jitter of the buffer; and additive random jitter due to power supply noise. There may be additional deterministic jitter sources that are not shown in Figure 19.

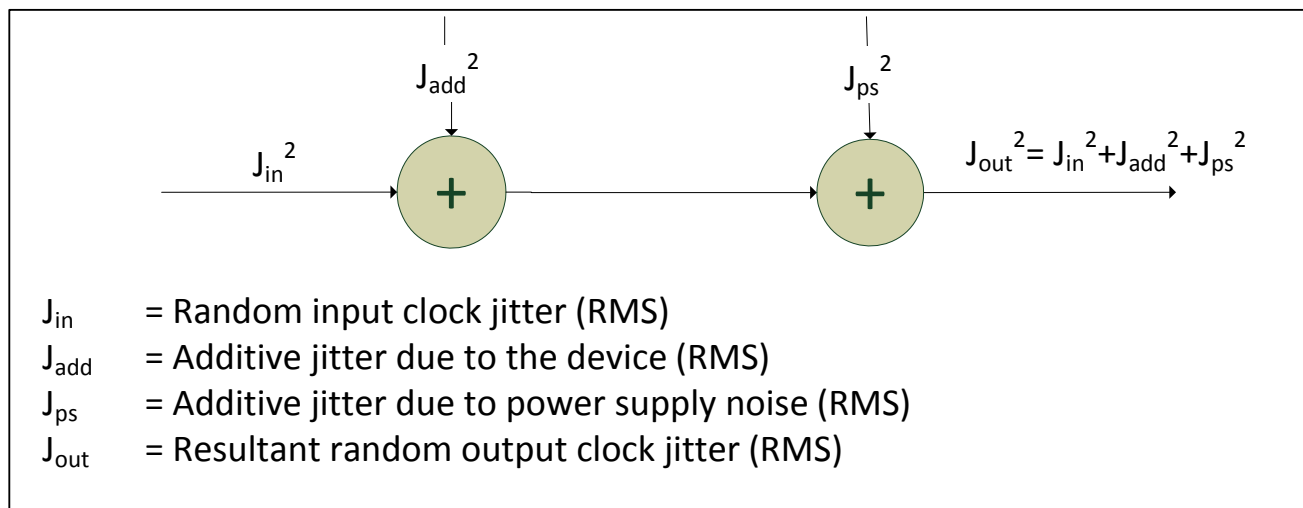

Figure 19 - Additive Jitter

3.5 Power Supply

This device operates with either a 2.5V supply or 3.3V supply.

3.5.1 Sensitivity to power supply noise

Power supply noise from sources such as switching power supplies and high-power digital components such as FPGAs can induce additive jitter on clock buffer outputs. The ZL40211 is equipped with an on-chip linear power regulator and on-chip bulk capacitors to minimize additive jitter due to power supply noise. The on-chip regulation, recommended power supply filtering, and good PCB layout all work together to minimize the additive jitter from power supply noise.

3.5.2 Power supply filtering

For optimal jitter performance, the ZL40211 should be isolated from the power planes connected to its power supply pins as shown in Figure 20.

- 10 μF capacitors should be size 0603 or size 0805 X5R or X7R ceramic, 6.3 V minimum rating
- 0.1 μF capacitors should be size 0402 X5R ceramic, 6.3 V minimum rating
- Capacitors should be placed next to the connected device power pins

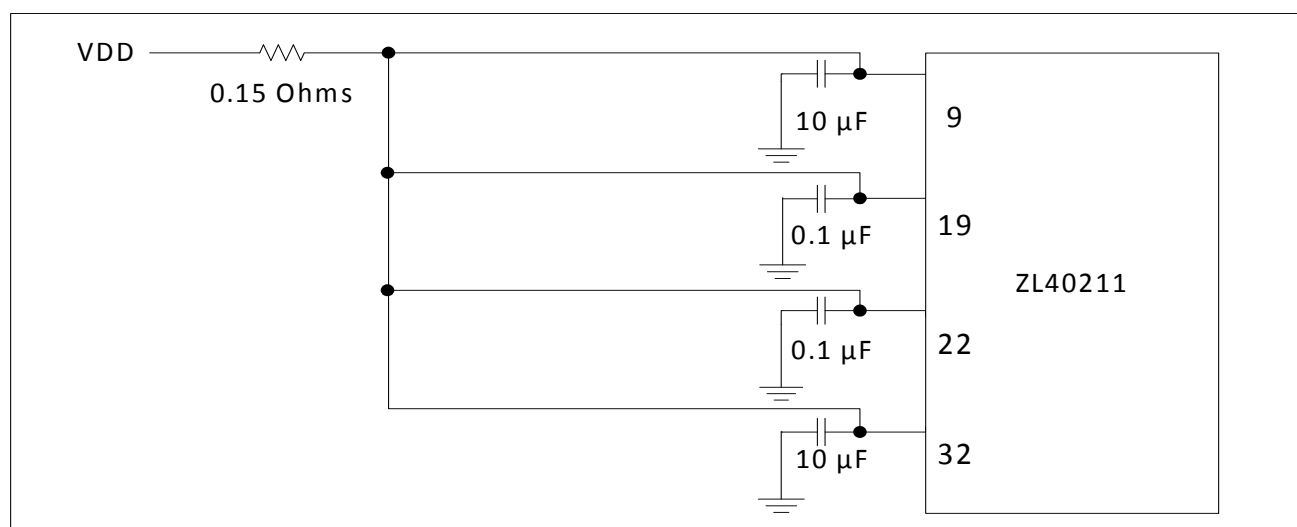

Figure 20 - Decoupling Connections for Power Pins

3.5.3 PCB layout considerations

The power supply filtering shown in Figure 20 can be implemented either as a plane island or as a routed power topology with equal results.

4.0 Electrical Characteristics

Absolute Maximum Ratings*

	Parameter	Sym.	Min.	Max.	Units
1	Supply voltage	V_{DD_R}	-0.5	4.6	V
2	Voltage on any digital pin	V_{PIN}	-0.5	V_{DD}	V
4	LVPECL output current	I_{out}		30	mA
5	Soldering temperature	T		260	°C
6	Storage temperature	T_{ST}	-55	125	°C
7	Junction temperature	T_j		125	°C
8	Voltage on input pin	V_{input}		V_{DD}	V
9	Input capacitance each pin	C_p		500	fF

* Exceeding these values may cause permanent damage. Functional operation under these conditions is not implied.

* Voltages are with respect to ground (GND) unless otherwise stated

Recommended Operating Conditions*

	Characteristics	Sym.	Min.	Typ.	Max.	Units
1	Supply voltage 2.5 V mode	V_{DD25}	2.375	2.5	2.625	V
2	Supply voltage 3.3 V mode	V_{DD33}	3.135	3.3	3.465	V
3	Operating temperature	T_A	-40	25	85	°C

* Voltages are with respect to ground (GND) unless otherwise stated

DC Electrical Characteristics - Current Consumption

	Characteristics	Sym.	Min.	Typ.	Max.	Units	Notes
1	Supply current LVPECL drivers - unloaded	I_{dd_unload}		122		mA	
2	Supply current LVPECL drivers - loaded (all outputs are active)	I_{dd_load}		257		mA	Including power to $R_L = 50\Omega$

DC Electrical Characteristics - Inputs and Outputs - for 3.3 V Supply

	Characteristics	Sym.	Min.	Typ.	Max.	Units	Notes
1	CMOS control logic high-level input voltage	V_{CIH}	$0.7 \cdot V_{DD}$			V	
2	CMOS control logic low-level input voltage	V_{CIL}			$0.3 \cdot V_{DD}$	V	
3	CMOS control logic Input leakage current	I_{IL}		1		μA	$V_I = V_{DD}$ or 0 V
4	Differential input common mode voltage	V_{CM}	1.1		2.0	V	

DC Electrical Characteristics - Inputs and Outputs - for 3.3 V Supply

	Characteristics	Sym.	Min.	Typ.	Max.	Units	Notes
5	Differential input voltage difference	V_{ID}	0.25		1	V	
6	Differential input resistance	V_{IR}	80	100	120	ohm	
7	LVPECL output high voltage	V_{OH}	$V_{DD} - 1.40$			V	
8	LVPECL output low voltage	V_{OL}			$V_{DD} - 1.62$	V	
9	LVPECL output differential voltage*	V_{OD}	0.5		0.9	V	

* This parameter is measured from 125 MHz to 750 MHz

DC Electrical Characteristics - Inputs and Outputs - for 2.5 V Supply

	Characteristics	Sym.	Min.	Typ.	Max.	Units	Notes
1	CMOS control logic high-level input voltage	V_{CIH}	$0.7 \cdot V_{DD}$			V	
2	CMOS control logic low-level input voltage	V_{CIL}			$0.3 \cdot V_{DD}$	V	
3	CMOS control logic Input leakage current	I_{IL}		1		μA	$V_I = V_{DD}$ or 0 V
4	Differential input common mode voltage	V_{CM}	1.1		1.6	V	
5	Differential input voltage difference	V_{ID}	0.25		1	V	
6	Differential input resistance	V_{IR}	80	100	120	ohm	
7	LVPECL output high voltage	V_{OH}	$V_{DD} - 1.40$			V	
8	LVPECL output low voltage	V_{OL}			$V_{DD} - 1.62$	V	
9	LVPECL output differential voltage*	V_{OD}	0.4		0.9	V	

* This parameter is measured from 125 MHz to 750 MHz



Figure 21 - Output Differential Voltage Parameter

AC Electrical Characteristics* - Inputs and Outputs (see Figure 22) - for 3.3 V supply.

	Characteristics	Sym.	Min.	Typ.	Max.	Units	Notes
1	Maximum Operating Frequency	$1/t_p$			750	MHz	
2	Input to output clock propagation delay	t_{pd}	0	1	2	ns	
3	Output to output skew	$t_{out2out}$		50	100	ps	
4	Part to part output skew	$t_{part2part}$		80	300	ps	
5	Output clock Duty Cycle degradation	t_{PWH}/ t_{PWL}	-2	0	2	Percent	
6	LVPECL Output slew rate	r_{SL}	0.75	1.2		V/ns	
7	Reference transition time	t_{switch}		2	3	us	

* Supply voltage and operating temperature are as per Recommended Operating Conditions

AC Electrical Characteristics* - Inputs and Outputs (see Figure 22) - for 2.5 V supply.

	Characteristics	Sym.	Min.	Typ.	Max.	Units	Notes
1	Maximum Operating Frequency	$1/t_p$			750	MHz	
2	input to output clock propagation delay	t_{pd}	0	1	2	ns	
3	output to output skew	$t_{out2out}$		50	100	ps	
4	part to part output skew	$t_{part2part}$		80	300	ps	
5	Output clock Duty Cycle degradation	t_{PWH}/ t_{PWL}	-2	0%	2	Percent	
6	LVPECL Output slew rate	r_{SL}	0.75	1.2		V/ns	
7	Reference transition time	t_{switch}		1	2	us	

* Supply voltage and operating temperature are as per Recommended Operating Conditions

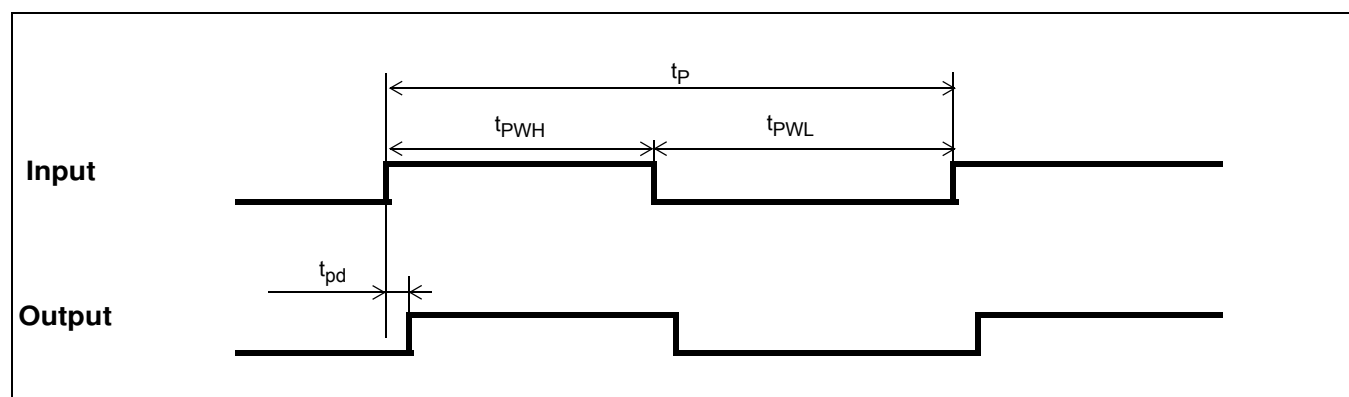

Figure 22 - Input To Output Timing

5.0 Performance Characterization

Additive Jitter at 2.5 V*

	Output Frequency (MHz)	Jitter Measurement Filter	Typical RMS (fs)	Notes
1	125	12 kHz - 20 MHz	190	
2	212.5	12 kHz - 20 MHz	159	
3	311.04	12 kHz - 20 MHz	147	
4	425	12 kHz - 20 MHz	132	
5	500	12 kHz - 20 MHz	126	
6	622.08	12 kHz - 20 MHz	118	
7	750	12 kHz - 20 MHz	106	

*The values in this table were taken with an approximate slew rate of 0.8 V/ns.

Additive Jitter at 3.3 V*

	Output Frequency (MHz)	Jitter Measurement Filter	Typical RMS (fs)	Notes
1	125	12 kHz - 20 MHz	193	
2	212.5	12 kHz - 20 MHz	167	
3	311.04	12 kHz - 20 MHz	157	
4	425	12 kHz - 20 MHz	144	
5	500	12 kHz - 20 MHz	137	
6	622.08	12 kHz - 20 MHz	127	
7	750	12 kHz - 20 MHz	116	

*The values in this table were taken with an approximate slew rate of 0.8 V/ns.

Additive Jitter from a Power Supply Tone*

Carrier frequency	Parameter	Typical	Units	Notes
125MHz	25 mV at 100 kHz	62	fs RMS	
750MHz	25 mV at 100 kHz	54	fs RMS	

* The values in this table are the additive periodic jitter caused by an interfering tone typically caused by a switching power supply. For this test, measurements were taken over the full temperature and voltage range for $V_{DD} = 2.5$ V. The magnitude of the interfering tone is measured at the DUT.

6.0 Typical Behavior

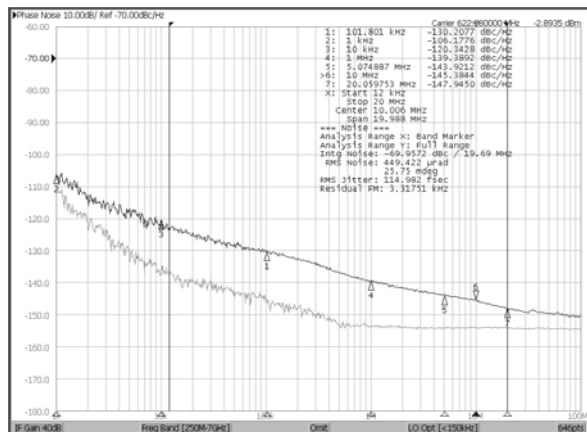

Typical Phase Noise at 622.08 MHz

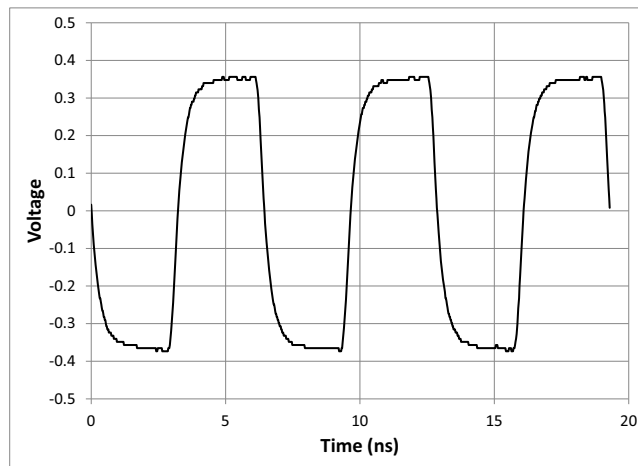

Typical Waveformat 155.52 MHz

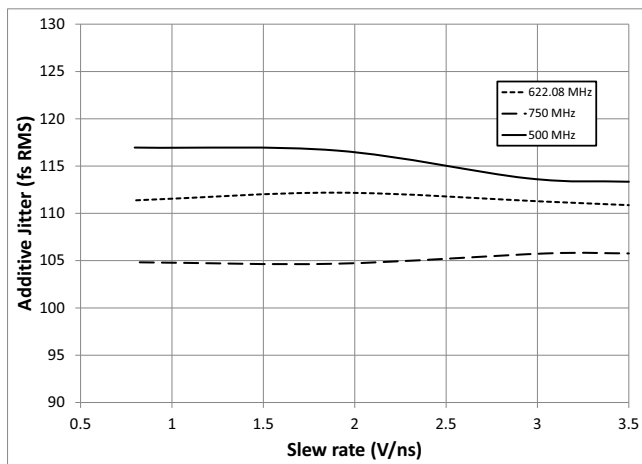

Input Slew Rate versus Additive Jitter

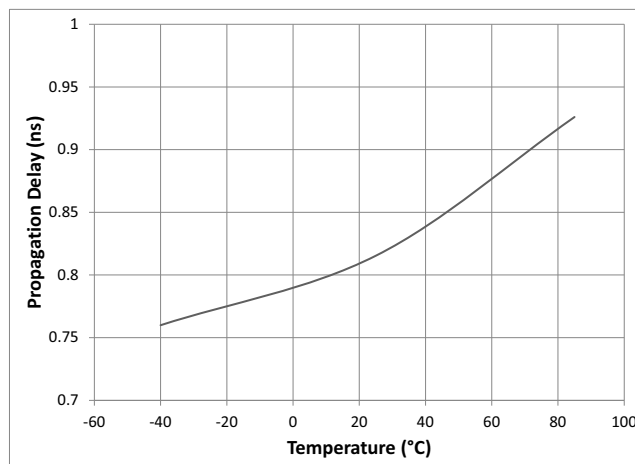

Propagation Delay versus Temperature

Note: This is for a single device. For more details see the

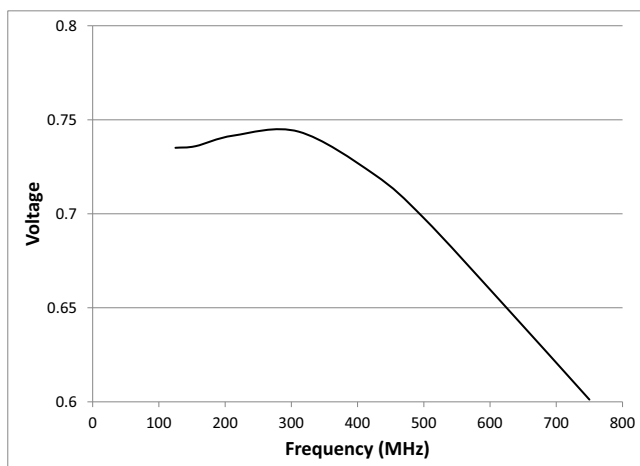

V_{OD} versus Frequency

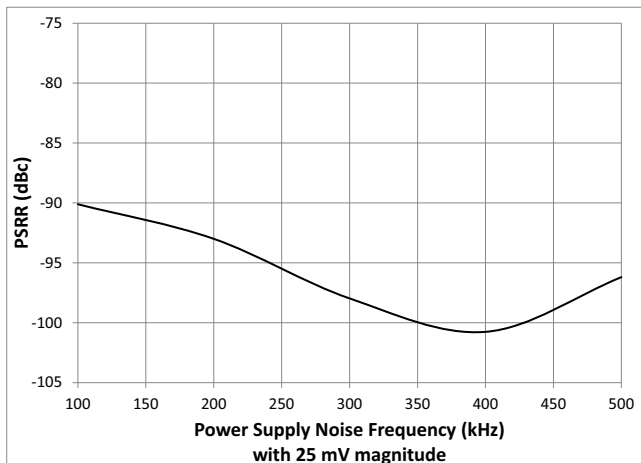

Power Supply Tone Frequency (at 25 mV) versus PSRR at 125 MHz

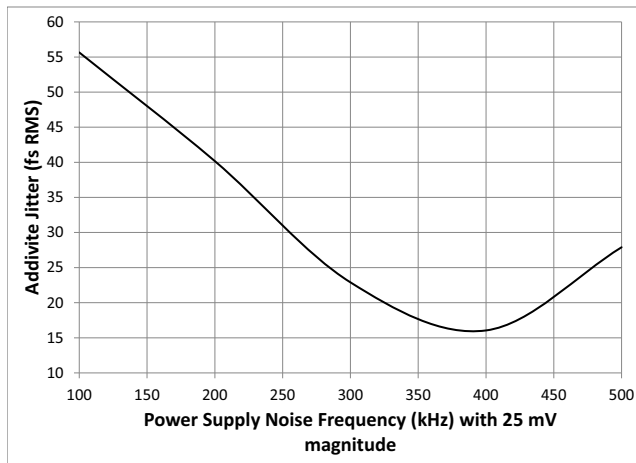

Power Supply Tone Frequency (at 25 mV) versus Additive Jitter at 125 MHz

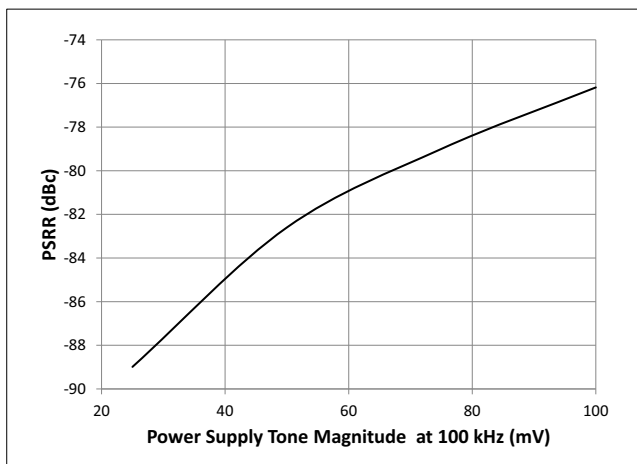

Power Supply Tone Magnitude (at 100 kHz) versus PSRR at 125 MHz

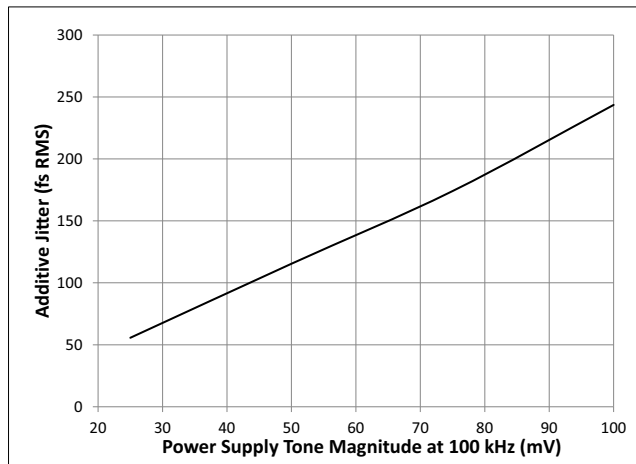

Power Supply Tone Magnitude (at 100 kHz) versus Additive Jitter at 125 MHz

7.0 Package Characteristics

Thermal Data

Parameter	Symbol	Test Condition	Value	Unit
Junction to Ambient Thermal Resistance	Θ_{JA}	Still Air	37.4	$^{\circ}\text{C}/\text{W}$
		1 m/s	33.1	
		2 m/s	31.5	
Junction to Case Thermal Resistance	Θ_{JC}		24.4	$^{\circ}\text{C}/\text{W}$
Junction to Board Thermal Resistance	Θ_{JB}		19.5	$^{\circ}\text{C}/\text{W}$
Maximum Junction Temperature*	T_{jmax}		125	$^{\circ}\text{C}$
Maximum Ambient Temperature	T_A		85	$^{\circ}\text{C}$

8.0 Mechanical Drawing

