



Chipsmall Limited consists of a professional team with an average of over 10 year of expertise in the distribution of electronic components. Based in Hongkong, we have already established firm and mutual-benefit business relationships with customers from,Europe,America and south Asia,supplying obsolete and hard-to-find components to meet their specific needs.

With the principle of “Quality Parts,Customers Priority,Honest Operation,and Considerate Service”,our business mainly focus on the distribution of electronic components. Line cards we deal with include Microchip,ALPS,ROHM,Xilinx,Pulse,ON,Everlight and Freescale. Main products comprise IC,Modules,Potentiometer,IC Socket,Relay,Connector.Our parts cover such applications as commercial,industrial, and automotives areas.

We are looking forward to setting up business relationship with you and hope to provide you with the best service and solution. Let us make a better world for our industry!



## Contact us

Tel: +86-755-8981 8866 Fax: +86-755-8427 6832

Email & Skype: info@chipsmall.com Web: www.chipsmall.com

Address: A1208, Overseas Decoration Building, #122 Zhenhua RD., Futian, Shenzhen, China



Spec.No.: MES-DG60B038A

SPECIFICATIONS  
FOR  
MANUAL INSERTION  
MAGNETIC CARD READER

Z U - 1 8 7 0 M A 6 T 2

MATSUSHITA ELECTRIC INDUSTRIAL CO.,LTD.

MATSUSHITA INDUSTRIAL EQUIPMENT CO.,LTD.

## CONTENTS

1. INTRODUCTION-----	P-1
2. COMPOSITION-----	P-1
3. SPECIFICATION-----	P-1
4. TERMINAL NO. OF CONNECTOR-----	P-3
5. INTERFACE REQUIREMENTS-----	P-3
6. NOTES FOR BETTER OPERATION-----	P-5
7. APPEARANCE-----	P-6
8. CONNECTOR DIMENSION-----	P-7
9. MAGNETIC CARD SPECIFICATION-----	P-7
10. LIFE OF PARTS-----	P-8
11. MAINTENANCE METHOD-----	P-8
12. CAUTIONS ON THE USE-----	P-8

## 1. INTRODUCTION

This specification applies to the Panasonic magnetic card reader, featuring small size, light weight and high performance.

## 2. COMPOSITION

The magnetic card reader is composed of the mechanical portion, double circuits for reading.

### 1) Mechanical portion

The mechanical portion is mainly composed of the following parts.

1. Body (Color:Transparence)
2. Card entrance slot (Color: Black)
3. Magnetic head
4. Rubber seal

### 2) Circuit portion

1. Read amplifier circuit for 2 tracks

## 3. SPECIFICATION

### 3.1 CARD STANDARD

Refer to Magnetic Card Specification (9).

### 3.2 FUNCTION

- |                                   |                          |
|-----------------------------------|--------------------------|
| (1) Read/Write                    | : Read only              |
| (2) Read timing                   | : Ejection               |
| (3) Compatibility                 | : Cards and installation |
| (4) Installation of the transport | : Horizontal direction   |

### 3.3 BASIC PERFORMANCE

#### (1) Performance

	ZU-1870MA6T2	
Card standard	ISO 7810,7811	
	IS01	IS02
Track used	Track 1st	Track 2nd
Recording method	FM	FM
Recording density	210 BPI	75 BPI
Recording Capacity	79 characters (7-bit code)	40 characters (5-bit code)

- (2) Card operation speed : 10 cm/s to 100 cm/s
- (3) Magnetic head Channel : 2  
Channel width : 1.4 mm
- (4) Insulation resistance : More than 10 MΩ at DC 250 V  
(Measured between P.C.B. ground terminal and frame)
- (5) UL File No. : E140407
- (6) Waterproof level : IPX4

### 3.4 ENVIRONMENT REQUIREMENTS

- (1) Temperature range : -20 °C to 60 °C  
(Operation)
- (2) Temperature range : -30 °C to 70 °C  
(Conservation)
- (3) Humidity range : 10 % RH to 90 % RH  
(Operation) (No condensation allowed)
- (4) Humidity range : 10 % RH to 90 % RH  
(Conservation) (No condensation allowed)
- (5) Vibration : Vibration sweep 10 Hz to 50 Hz,  
sweep 0.5 oct/min  
X,Y,Z directions : 10 m/s<sup>2</sup>
- (6) Shock durability : 294 m/s<sup>2</sup> (30 G)

### 3.5 PHYSICAL CHARACTERISTICS

- (1) Dimension : (W) 90 mm x (D) 119.5 mm x (H) 46 mm
- (2) Mass : Approx. 100 g
- (3) Power supply : DC 5 V  $\pm$  0.5 V / Ripple(Less than 25 mA)
- (4) Ripple : Within 50 mV<sub>p-p</sub>
- (5) Operating place : Indoor

### 3.6 ERROR RATE

(at indoor conditions by continuous running)

- (1) Error : Less than 0.5 %

\* Condition .....In a clean office room.

In damp or dusty atmosphere, the life may be 1/3 to 1/5 of the above figure.

## 4. TERMINAL NO. OF CONNECTOR

### 4.1 OUTPUT SIGNAL

Connector Pin No.	Signal name	Connector Pin No.	Signal name
1	DC 5 V	5	/RCL2
2	/RDT1	6	/CLD
3	/RCL1	7	GND
4	/RDT2	-	-

Connector: 641216-7

## 5. INTERFACE REQUIREMENTS

### 5.1 OUTPUT VOLTAGE

	Min(V)	Max(V)	Conditions
H level "0"	4.0	V <sub>cc</sub>	I <sub>OH</sub> = -1.0 mA
L level "1"	-	0.4	I <sub>OL</sub> = 4.0 mA

## 5.2 OUTPUT SIGNALS

The following paragraphs describe the requirements and interface signals between the user terminal and the Magnetic Card Reader shown in Figure 1.

The general timing sequence for entering data from the Magnetic Card Reader to the user terminal is shown in Figure 2.

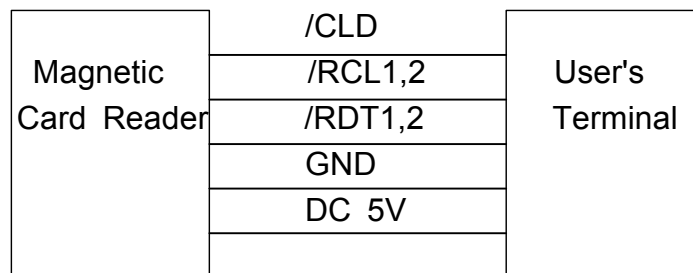

Figure 1

### (1) /CLD (CARD LOAD)

The /CLD line will be High when a Magnetic Card is inserted in the end of Magnetic Card Reader.

The /CLD line will be Low at all other times.

### (2) / RCL1,2 (READ CLOCK)

This is used to sample the data line by it's falling edges.

The time relationship of the clock with respect to the other signals is shown in Figure 2.

User's Terminal starts to carry out sampling of the read data by the falling edge of the signal.

In case of performing sampling other than the falling edge sampling method

(such as detecting "L" of /RCL by means of polling)to read /RDT, check /RCL width if it is appropriate.

### (3) /RDT1,2 (READ DATA)

At the moment /RCL change from High to Low ;

/RDT is "1" when the /RDT line is Low, and

/RDT is "0" when the /RDT line is High.

### 5.3 TIMING CHART

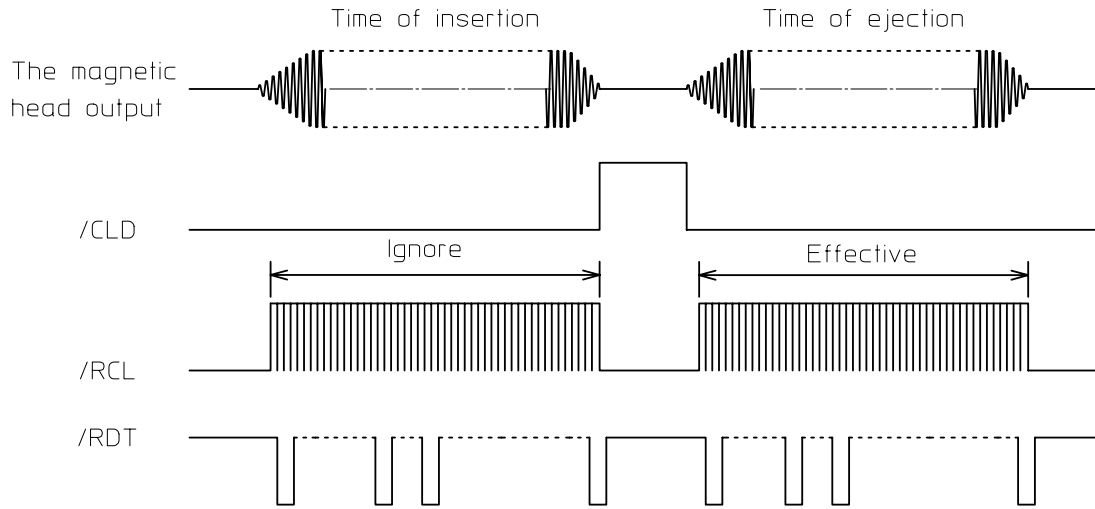

#### Detail Chart

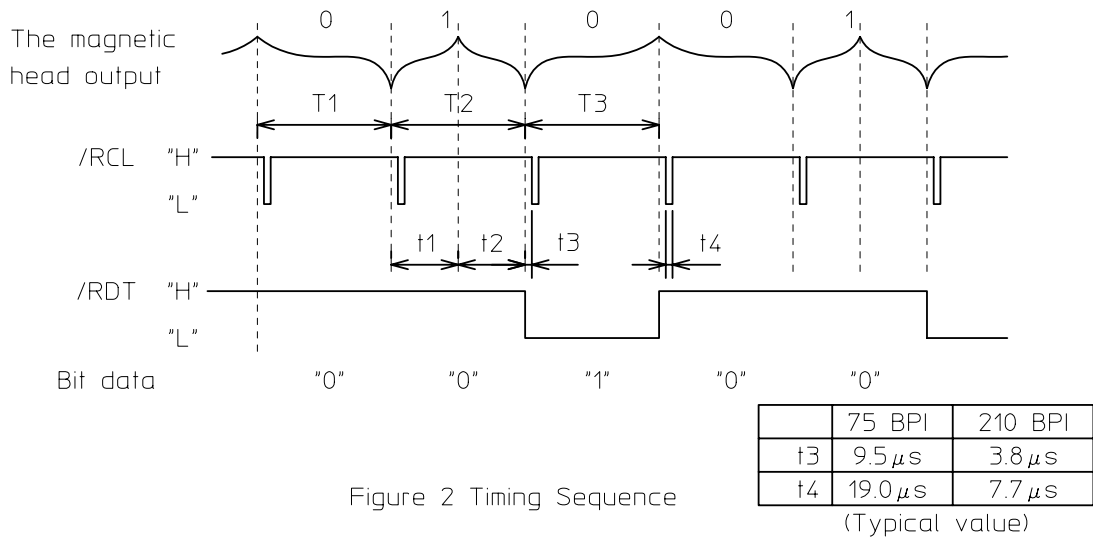

Figure 2 Timing Sequence

When the jitter of the magnetic head output is 0 % , the following equation is satisfied.

$$T=T1=T2=T3, t1=t2$$

$$\text{Note : } T \text{ (s)} = \frac{2.54 \text{ cm/inch}}{\text{Recording density (BPI)}} \times \frac{1}{\text{Card speed (cm/s)}}$$

### 6. NOTES FOR BETTER OPERATION

- (1) The card should be inserted in the specified direction.
- (2) The card which conformed ISO standard should be used.
- (3) The cards should not be dirty, scratched or deformed.



## 7. APPEARANCE

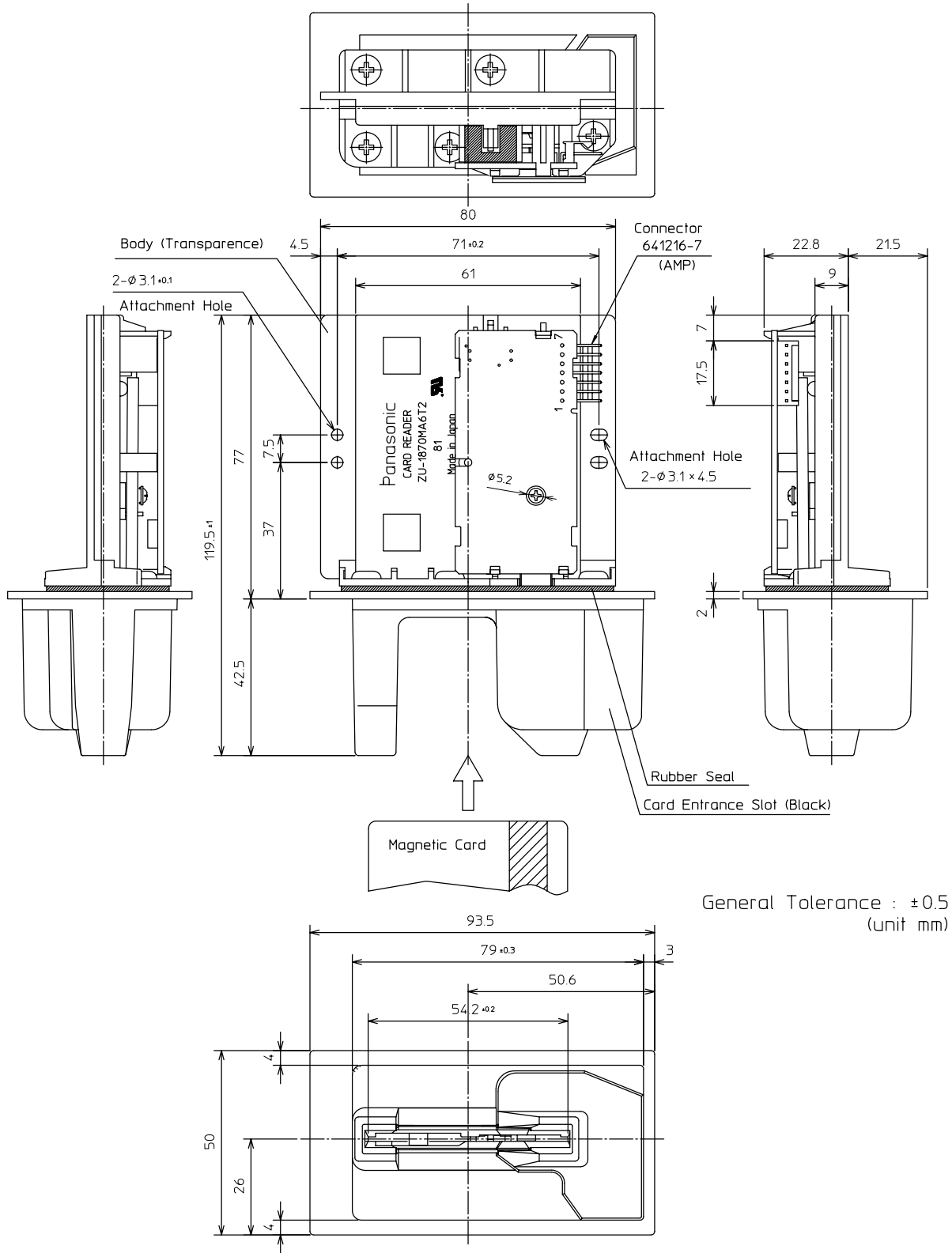

8. CONNECTOR DIMENSION  
POST(641216-7 AMP)

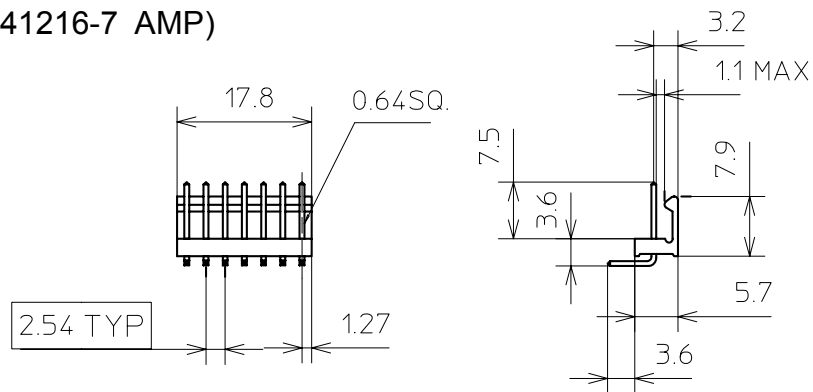

9. MAGNETIC CARD SPECIFICATION  
9.1 CARD SPECIFICATION

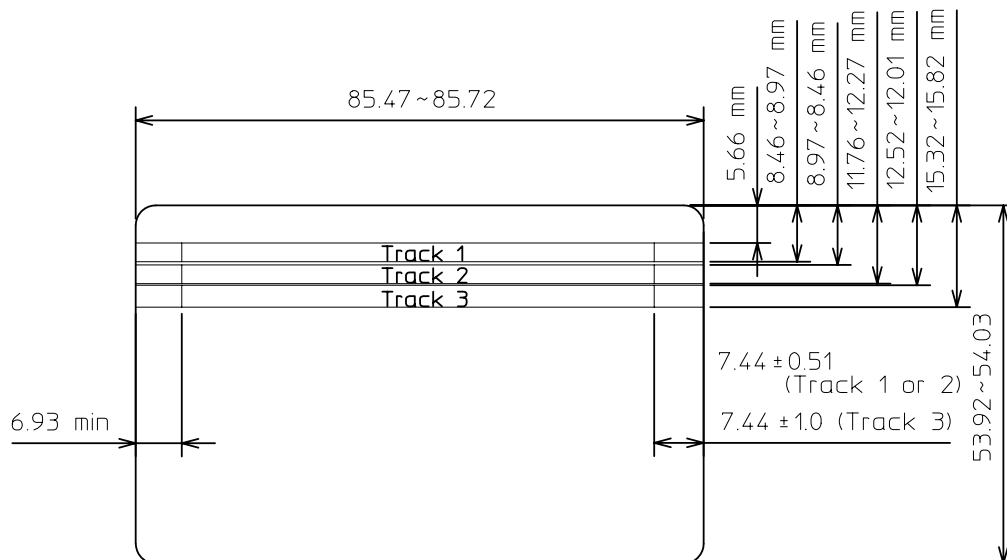

- (1) Thickness : 0.76 mm (tolerance ± 0.08 mm)
- (2) Transformation : 2 mm max.
- (3) Impermeability rate : More than 2.0  
(Measured by light permeance desitometer)

9.2 MAGNETIC CHARACTERISTICS

- (1) Coercive force (Hc) :  $2.4 \times 10^4$  A/m (300 Öe ± 12%)
- (2) Residual flux ( $\phi_r$ ) :  $1.25 \times 10^{-8}$  Weber/cm  
( $1.25 \pm 0.15$  maxwell/cm)
- (3) Squareness ratio ( $\phi_r/\phi_m$ ) : More than 0.70

## 10. LIFE OF PARTS

Magnetic head : 500,000 passes

\*Condition ..... In a clean office room.

In damp or dusty atmosphere, the life may be  
1/3 to 1/5 of the above figure.

## 11. MAINTENANCE METHOD

When replacing parts, exchange the card reader unit.

## 12. CAUTIONS ON THE USE

Please be noted that we do not guarantee proper performance of the card reader if it is used other than the indicated specification range.

### 12.1 At the installation

- (1) Do not drop or bump anything against a card reader.  
Otherwise, failure may be the result.
- (2) Do not touch the P.C.B. with bare hands.
- (3) Be sure to install on a flat surface so as to prevent any force to be applied to the card reader at the installation.
- (4) Installation of a card guide plate at the both (front and back) sides of the card running part may reinforce stability.
- (5) The card reader should avoid installation of the following environment.
  - Watery, humid or dusty place.
  - Near machines which generate magnetic field or inducted noise.  
(printer, LED display, CRT etc.)
  - Place which gets direct sunlight.

## 12.2 At the use

- (1) Be sure to use a card which conforms ISO standard.  
Anti-magnetic of the applied card should be  $2.4 \times 10^4$  A/m to  $2.4 \times 10^5$  A/m (300 Öe to 3000 Öe) of ISO standard.
- (2) Pulse width of the period "L" of /RCL is about  $7.7 \mu\text{S}$  for the card conformable to ISO1 (210 BPI specification), and about  $19 \mu\text{S}$  in case of ISO2 (75 BPI specification). If sampling method other than falling edge sampling (such as a method detecting "L" of /RCL by means of polling ) is used, please check with us since data may not be read depending on polling frequency at the host side.
- (3) Card operation speed should be within the specification range.  
Forced stop or change of speed during the card operation may cause a read error.  
Appropriate speed to maintain stable operation is 30 cm/s to 60 cm/s.
- (4) Store the card with caution to prevent dirt, scratch and distortion.  
Especially no foreign matter shall be stuck on the magnetic stripe surface. Use of such card may result in a read error.
- (5) Insert a cleaning card and clean the head periodically to prevent wearing of the magnetic head.  
Head cleaning using the cleaning card should be performed about once a week if the room is not dusty.
- (6) Depends on installation environment (incorporation condition) or operation condition, external noise or electrostatic and so on may affect the machine, and which may cause an error or a wrong operation. Check the level of noise resistance and electrostatic resistance of your factory before using the card reader.
- (7) Be careful not to splash the gasoline or light oil on the head cover (Rubber seal). There is possibility that the rubber seal spoil its water proof performance due to expansion or transformation.
- (8) Please avoid touch rubber seal directly. It is possible that the rubber seal spoil its water proof performance due to transformation or split.