



Chipsmall Limited consists of a professional team with an average of over 10 year of expertise in the distribution of electronic components. Based in Hongkong, we have already established firm and mutual-benefit business relationships with customers from,Europe,America and south Asia,supplying obsolete and hard-to-find components to meet their specific needs.

With the principle of "Quality Parts,Customers Priority,Honest Operation,and Considerate Service",our business mainly focus on the distribution of electronic components. Line cards we deal with include Microchip,ALPS,ROHM,Xilinx,Pulse,ON,Everlight and Freescale. Main products comprise IC,Modules,Potentiometer,IC Socket,Relay,Connector.Our parts cover such applications as commercial,industrial, and automotives areas.

We are looking forward to setting up business relationship with you and hope to provide you with the best service and solution. Let us make a better world for our industry!



Contact us

Tel: +86-755-8981 8866 Fax: +86-755-8427 6832

Email & Skype: info@chipsmall.com Web: www.chipsmall.com

Address: A1208, Overseas Decoration Building, #122 Zhenhua RD., Futian, Shenzhen, China



**SPECIFICATION for
MAGNETIC CARD READER
BUILT IN RS232**

Model #

ZU-1870MA8R2

Revision 1.00

JUL 2004

PRECAUTIONS

READ THIS SECTION CAREFULLY BEFORE INSTALLING OR USING THIS READER MODULE.

- **Usage**

Avoid Extreme Heat and Cold

Do not store or use the reader module in locations exposed to heat, direct sunlight, or extreme cold.

Avoid moving the device with which it was incorporated between locations with large temperature differences. If the moisture condensation should occur, do not use the device.

Operation: -10 °C to +50 °C

Storage: -20 °C to +60 °C

Avoid Humidity, Liquids and Dust

Do not store or use the reader module in locations exposed to high humidity, liquids (include rain) or dust.

If used in dusty conditions, the magnetic head life will be shortened.

Avoid Corrosive Gases

Keep the reader module away from oil or corrosive gases (salt, brimstone, chlorine, acid, alkali, etc.).

Avoid Radio Frequency Interference

Do not use the reader module near a television or radio receiver.

Avoid Magnetic Fields

Keep the reader module away from magnets and magnetic field sources, such as high voltage, strong electrical current, magnetic security devices or industrial equipment (speakers, microwave ovens and CRT display, etc.).

Avoid Locations Near Electrical Appliances or Other Devices that Emit Electrical Noise

Keep the reader module away from electrical noise sources, such as electric motors, printer, or computer equipment.

Keep Clean the Magnetic Head

Dirt, metal dust and magnetic particles etc. may cause read error.

You need to clean the magnetic head using the cleaning cards.

Cleaning is recommended every week or when read problems occur.

Do Not Apply More than the Specified Voltages

Do not apply any reverse voltage.

Voltage: DC +4.75 V to +12 V

Do Not Use a Cracked or Deformed Card

Store the card with caution to prevent dirt, scratch and distortion. No foreign matter should be stuck on the magnetic stripe surface. Use of such card may result in a read error.

- **Handling**

Do Not Disassemble the reader module

Do not attempt to disassemble, or modify it.

Do Not Touch the Printed Circuits, Connector Pins or Components

Before handling the reader module, discharge the static electricity from your body by wearing on the ESD protection such as a grounded wrist strap.

Always handle it by the frame.

Avoid Dropping, Bumping or Strong Impact

Avoid subjecting the reader module to severe vibrations or impact.

Do Not Connect or Disconnect Any Cables while the Power supply is turned On

- **Others**

Use Specified Cards

Be sure to use a card, which conforms to ISO standard. Anti-magnetic of the applied card should be 2.4×10^4 A/m to 2.4×10^5 A/m of ISO standard.

Use a card which is encoded the magnetic strip on the front or back of the card. Do not support to read a card which is encoded on both side of the front and back of the card.

Card operation speed should be within the specification range. Forced stop or change of speed during the card operation may cause a read error. Appropriate speed to maintain stable operation is 30 cm/s to 60 cm/s.

Be Careful when Handling and Storage the Cards

Do not bend or twist the cards.

Do not attach oil, fats or any greasy substance on the cards.

TABLE OF CONTENTS

1. INTRODUCTION	1
1.1. RELATED DOCUMENTS.....	1
1.2. DEFINITIONS	1
2. SPECIFICATIONS	2
2.1. PRODUCT NAME	2
2.2. FEATURES	2
2.3. FUNCTION	2
2.4. PHYSICAL DIMENSIONS.....	2
2.5. POWER SUPPLY.....	2
2.6. ENVIRONMENTS	3
2.7. LIFE AND RELIABILITY.....	3
2.8. MAGNETIC STRIPE CARD STANDARD.....	4
2.8.1. PARAMETERS	4
2.8.2. PHYSICAL CHARACTERISTICS	4
2.8.3. MAGNETIC CHARACTERISTICS.....	4
2.8.4. LOCATION OF TRACKS	5
2.9. BLOCK DIAGRAM	6
2.10. CONNECTORS.....	7
2.10.1. CARD READER CONNECTOR.....	7
2.10.2. HOST RS-232C CONNECTOR (PC/AT compatible)	7
3. HOST PROTOCOL	8
3.1. PHYSICAL LAYER.....	8
3.2. TRANSPORT LAYER.....	8
3.2.1. COMMAND FORMAT	8
3.2.2. RESPONSE FORMAT	9
3.2.3. COMMUNICATION SEQUENCE	10
3.3. COMMAND LAYER.....	12
3.3.1. CONFIGURATION COMMANDS.....	13
Change Baud Rate	13
Auto Clear	14
Auto Send	15
Auto Notify	16
3.3.2. STATUS COMMANDS.....	17
Send Reader Status	17
Send Track Status.....	19
Send Firmware Version.....	20
3.3.3. TRACK DATA COMMANDS	21
Clear Track Data	21
Transmit Track Data.....	22
3.3.4. READER COMMANDS.....	23
Reset Reader.....	23

4. MAINTENANCE..... 24

5. APPEARANCE..... 25

1. INTRODUCTION

This specification describes Panasonic's manual insertion type Magnetic Card Reader (UCI-MAG) with built in RS232 interface and decoder.

1.1. RELATED DOCUMENTS

ISO/IEC 7810:2003	Identification cards – Physical characteristics
ISO/IEC 7811-1:2002	Identification cards – Recording technique – Part 1: Embossing
ISO/IEC 7811-2:2001	Identification cards – Recording technique – Part 2: Magnetic stripe – Low coercively
ISO/IEC 7811-3:1995	Identification cards – Recording technique – Part 3: Location of embossed characters on ID-1
ISO/IEC 7811-4:1985	Identification cards – Recording technique – Part 4: Location of read-only magnetic tracks – Tracks 1 and 2
ISO/IEC 7811-5:1985	Identification cards – Recording technique – Part 5: Location of read-write magnetic track – Track 3

1.2. DEFINITIONS

The glossaries to be used in this document are defined as follows (by alphabetically order).

ASCII	American Standard Code for Information Interchange
CR	ASCII Carriage Return (0Dh)
LF	ASCII Line Feed (0Ah)
SH	High digit of 8 bit hexadecimal checksum
SL	Low digit of 8 bit hexadecimal checksum

2. SPECIFICATIONS

2.1. PRODUCT NAME

Product Name: Manual insertion type magnetic card reader built in RS232 (Full insertion type)
Model No.: ZU-1870MA8R2

2.2. FEATURES

Magnetic Head: Double sided heads
Reading Track: 2 tracks (ISO1 and ISO2)
Reading Speed: 10 cm/s to 120 cm/s
Raindrop proof: IPx4

2.3. FUNCTION

Card Operation: Insertion / Ejection
Read/Write: Read only
Reading Direction: Backward (Ejection)

2.4. PHYSICAL DIMENSIONS

Width: 93.5 mm
Depth: 121.0 mm
Height: 50.0 mm
Weight: Approx. 125 g

2.5. POWER SUPPLY

Voltage: DC +4.75 V to +12 V
Ripple: Less than 50 mV p-p
Current Consumption: Approx. 30 mA

2.6. ENVIROMENTS

Operating Temperature:	-10 °C to +50 °C
Operating Humidity:	10 % RH to 90 % RH (No condensation allowed)
Storage Temperature:	-20 °C to +60 °C
Storage Humidity:	10 % RH to 95% RH (No condensation allowed) (24hours)
* Test procedure:	Place the card reader in the standard environment (temperature: 20 °C ± 5 °C, humidity: 35 % RH to 60 % RH). Leave it for 12 hours, and measure the functions. Make sure no abnormality is found.
Vibration Sweep:	10 Hz/mm to 50 Hz/mm (X, Y, Z directions)
Shock Durability:	294 m/s ² (30 G)
Usage:	Out door is available.
Others:	Make sure any source of noise that may deteriorate the characteristics of the card reader is not present around the card reader.

2.7. LIFE AND RELIABILITY

Magnetic Head: 500,000 times pass (2 passes / operation)

Note: The life is reliability number based on the result tested in a “clean office” environment. These numbers may be shortened dependent on the actual environment. Especially in a dusty environment, even in the indoor application, dust or sand may shorten the life against the mechanical parts and most of the card transport mechanisms. In these cases, warranty of the card reader may be void unless the proper protection and countermeasures are performed by the terminal side. (In a clean office room. In damp or dirty atmosphere, the life may be 1/3 to 1/5 of the above figure.)*

**dusty environment: Refer to e.g. IEC 68, EN30721-3-3 class 3S2 or worse.*

2.8. MAGNETIC STRIPE CARD STANDARD

2.8.1. PARAMTERS

Card Specification:

Track Position	Track 1 ISO1	Track 2 ISO2
Recording Method	F2F	F2F
Recording Density	210 BPI	75 BPI
Recording Capacity	79 characters (7 bits)	40 characters (5 bits)

2.8.2. PHYSICAL CHARACTERISTICS

Thickness: 0.76 mm \pm 0.08 mm

Warpage: 2.5 mm max. (include relief height of embossed characters)

2.8.3. MAGNETIC CHARACTERISTICS

Coercive Force (Hc): 2.4×10^4 A/m to 2.4×10^5 A/m

Residual Flux (ϕ_r): 1.25×10^{-8} Wb/cm \pm 0.15×10^{-8} Wb/cm

Squareness Ratio(ϕ_r/ϕ_m): more than 0.70

2.8.4. LOCATION OF TRACKS

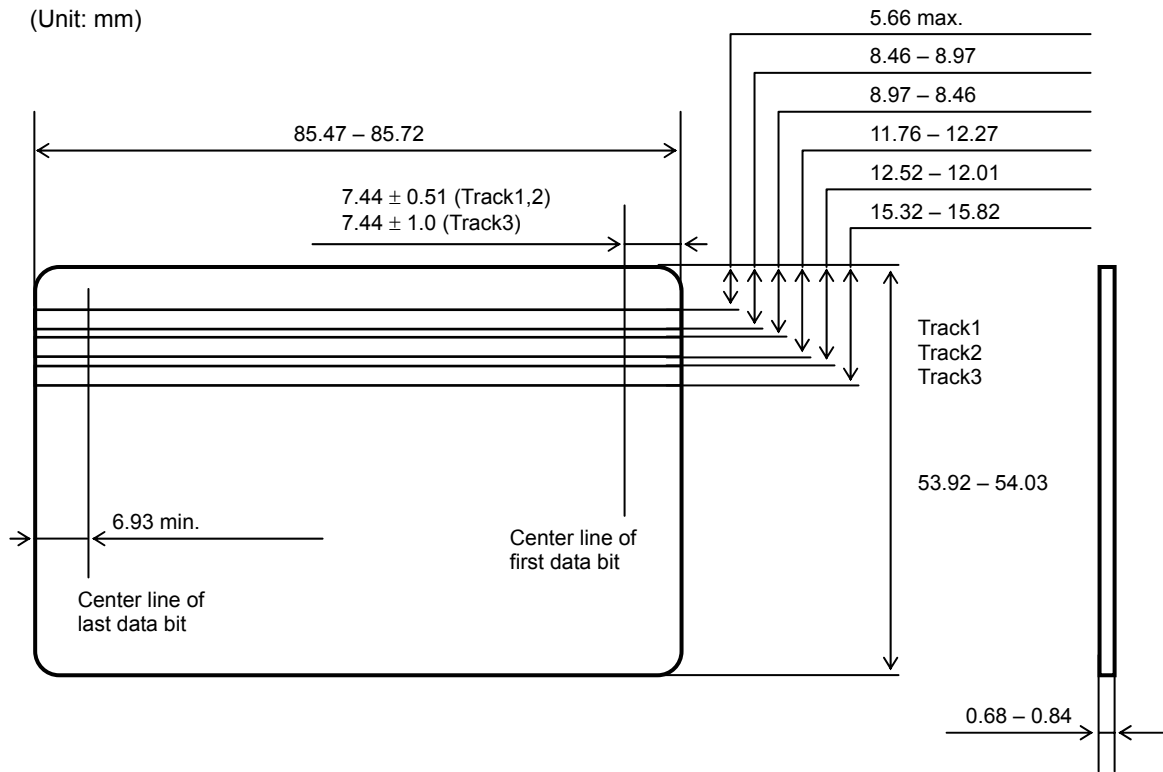

2.9. BLOCK DIAGRAM

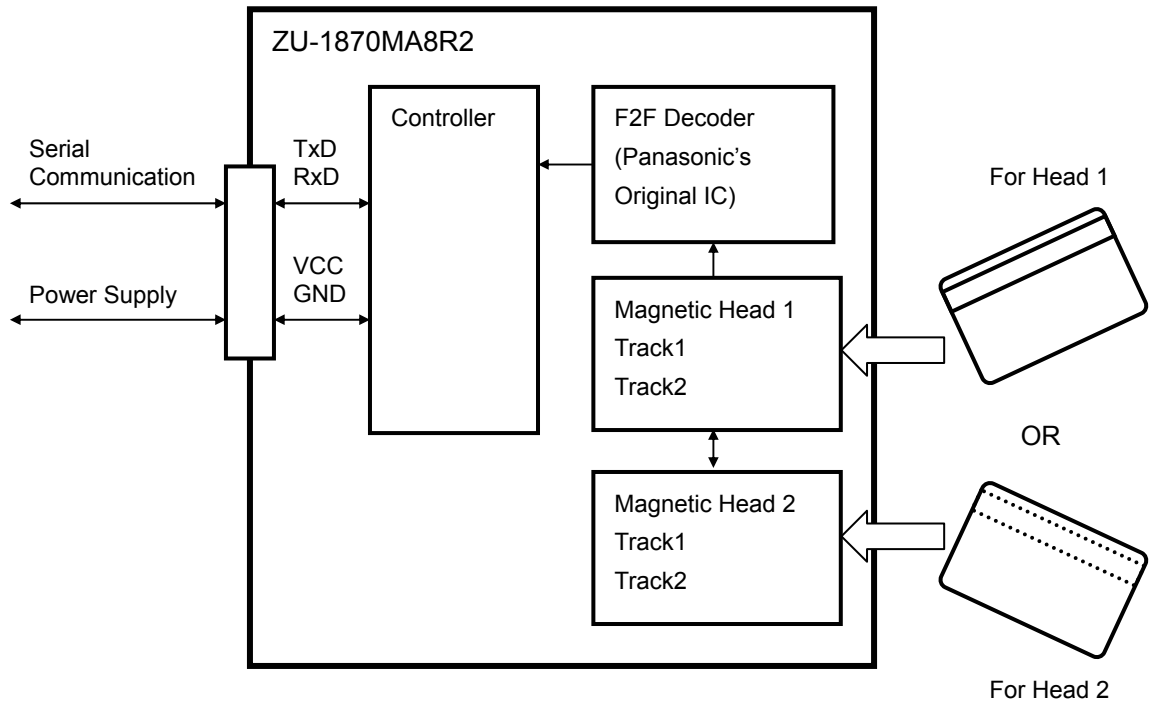

2.10. CONNECTORS

2.10.1. CARD READER CONNECTOR

Connector Name: CN1
 Model No.: 53261-0590 (Molex)
 Mating Connector: 51021-0500 (Molex)

Pin Assignments:

Pin #	Signal Name	I/O	Description
1	SG	-	Signal Ground
2	RxD	In	Serial Receive
3	TxD	Out	Serial Transmit
4	Vcc	-	Power supply (DC 4.75V to 12V)
5	Vcc	-	Power supply (DC 4.75V to 12V)

2.10.2. HOST RS-232C CONNECTOR (PC/AT compatible)

Connector Name: DB-9

Pin Assignments:

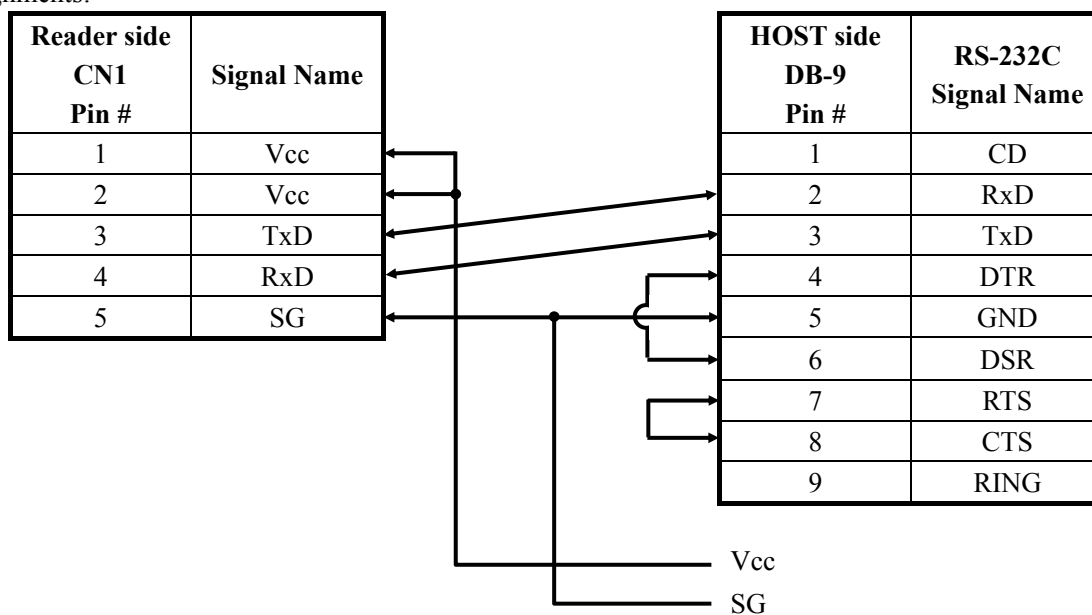

3. HOST PROTOCOL

3.1. PHYSICAL LAYER

The list of communication parameters is shown below:

Item	Contents
Transmission Protocol	Asynchronous
Communication Method	Half-duplex
Start bit	1 bit
Data length	8 bits
Parity	None
Stop bit	1 bit
Communication Speed	9600 / 19200 bps

The baud rate is selectable, and it can be changed using a *Change Baud Rate* command.

The setup at factory shipping is 9600 bps.

3.2. TRANSPORT LAYER

3.2.1. COMMAND FORMAT

:	CMD	PARAM	CR
(1 byte)	(1 byte)	(0 to more)	(1byte)

Field	Value	Description
:	3Ah	Colon; Shows the start of message packet.
CMD	Any value	Command Code; Defined in "3.3 COMMAND LAYER"
PARAM	Any value	Parameter; Defined in "3.3 COMMAND LAYER"
CR	0Dh	Carriage Return; Shows the end of message packet.

3.2.2. RESPONSE FORMAT

Response format with a data:

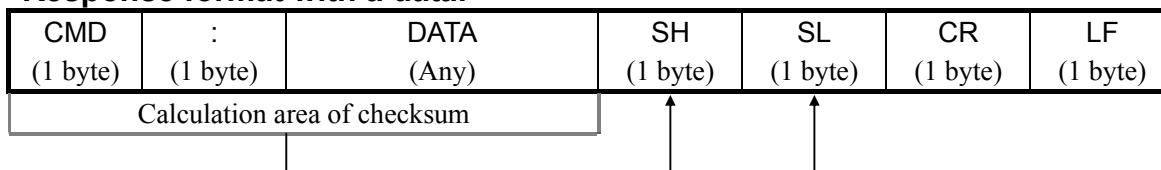

Response format without a data:

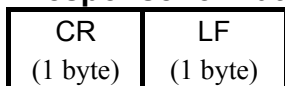

Field	Value	Description
CMD	Any value	Command Code; Shows the
:	3Ah	Colon; Splits command code and a data field.
DATA	Any value	Data; Defined in "3.3 COMMAND LAYER"
SH	Any value	High digit of 8 bits hexadecimal checksum*
SL	Any value	Low digit of 8 bits hexadecimal check sum*
CR	0Dh	Carriage Return; Shows the end of message packet.
LF	0Ah	Line Feed; Shows the end of message packet.

*Calculating Procedure of Checksums

In case of example that a return data is "SE:400000030000".

1st step: "S" (53h) + "E" (45h) + ":" (3Ah) + "4" (34h) + "0" (30h) + "0" (30h) + "0" (30h) + "0" (30h) + "0" (30h) + "0" (30h) + "3" (33h) + "0" (30h) + "0" (30h) + "0" (30h) + "0" (30h) = 319h

2nd step: Neglect 3h (upper byte of 319h)

3rd step: Calculate the two's complement value of 19h (lower byte of 319h)

$$100h - 19h = E7h \text{ (E7h is the two's complement value of 19h)}$$

Consequently SH is "E" (45h) and SL is "7" (37h)

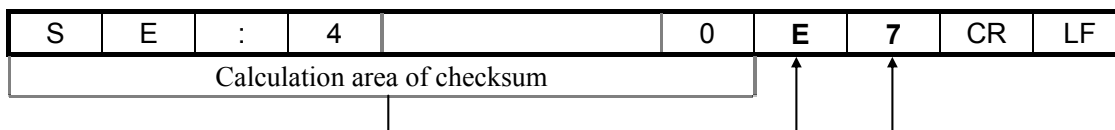

3.2.3. COMMUNICATION SEQUENCE

Normal Communication Sequence

Normal communication sequence is shown in next figure.

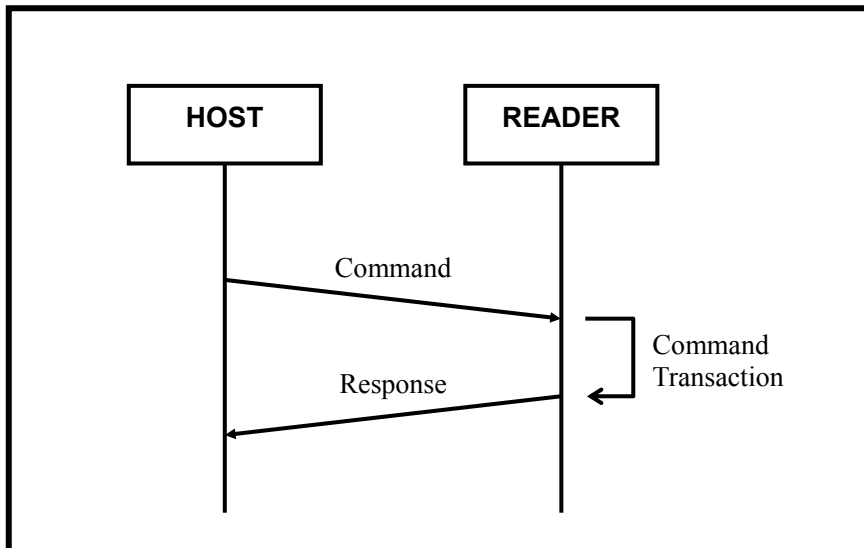

Communication Errors and Retry Sequence

Communication Errors and Retry sequence is shown in next figure.

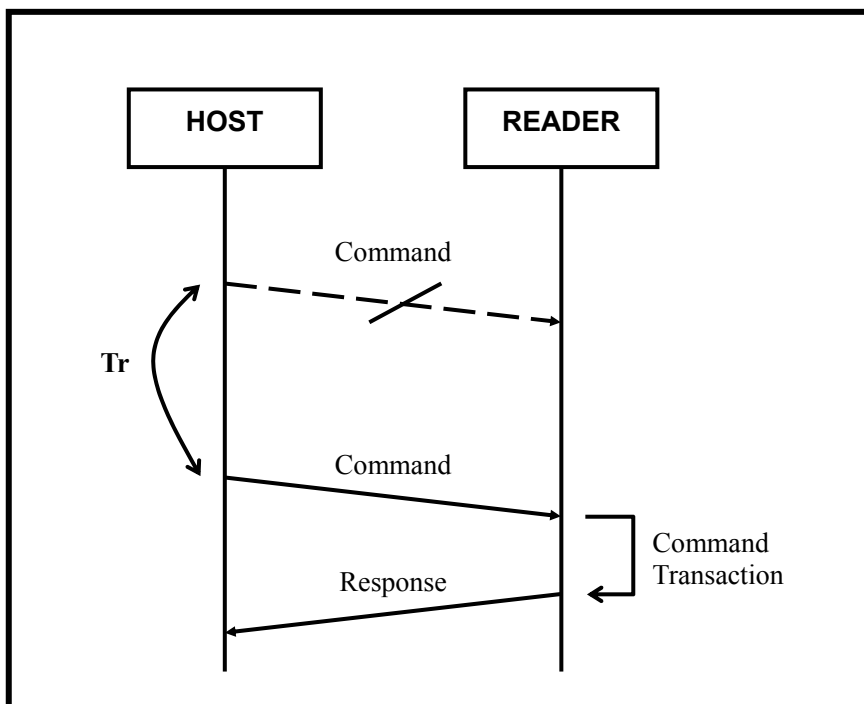

When the reader doesn't respond for **Tr** (Retry wait), HOST may retries the request.

Tr should be more than 1 second when using commands with timeout.

Magnetic Card Read Polling Sequence

Magnetic Card Read Polling sequence is shown in next figure.

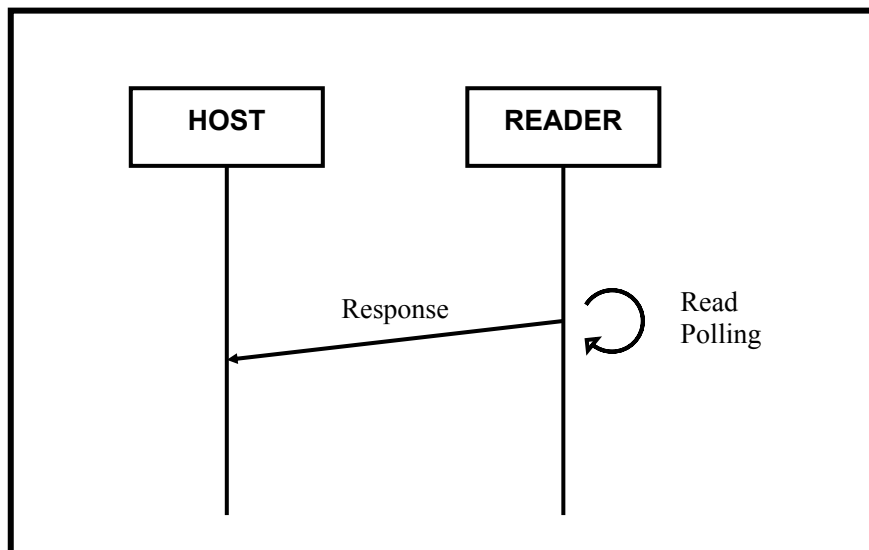

AUTOSEND/AUTONOTIFY mode are enabled, a response is automatically transmitted at time of card inserted and card read.

The message transmitted with the combination in the mode is shown below:

Mode		Response		
AUTO SEND	AUTO NOTIFY	Card Insert	Card Read (with no error)	Card Read with ejection (with error)
Enable	Disable	-	<Track data>	“error.”
Disable	Enable	“Card Inserted”	“Track Read”	“Track Read”
Enable	Enable	“Card Inserted”	<Track data>	“error.”
Disable	Disable	-	-	-

“” quotation mark means message strings.

3.3. COMMAND LAYER

Classification	Command	Code	Description
Configuration Commands	Change Baud Rate	B	Sets the communication speed.
	Auto Clear	A	Automatically clear track buffers after sending track data.
	Auto Send	S	Automatically send track data as soon as card has been swiped.
	Auto Notify	N	Automatically send the message as soon as card has been swiped.
Status Commands	Send Reader Status	SR	Sends the reader status, its configuration.
	Send Track Status	ST	Sends the track status.
	Send Firmware Version	V	Sends the firmware version of the reader.
Track Data Commands	Transmit Track Data	T	Transmits a data on track.
	Clear Track Data	C	Clears track buffers.
Reader Commands	Reset Reader	RX	Reset the reader.

3.3.1. CONFIGURATION COMMANDS

All configurations set up by the configuration commands are saved at an EEPROM. After a power up the reader, all configurations are loaded from EEPROM.

Change Baud Rate

Description:

This command sets the serial I/O line baud rate.

Command:

Bx

Where:

x is the baud rate number. The specifies values are as follows:

Value	Baud rate
“3” (33h)	9600 bps (Setup at factory shipping)
“4” (34h)	19200 bps

Response:

[CR][LF]

Note: The response is returned with the OLD baud rate.

Example:

Command for set the serial I/O line baud rate is 19200bps:

:	B	4	[CR]
3Ah	42h	34h	0Dh

Auto Clear

Description:

This command sets AUTOCLEAR bit.

Command:

Ab

Where:

b is the AUTOCLEAR bit. The specifies values are as following:

Value	Auto Clear
"0" (30h)	Disable
"1" (31h)	Enable

Note: If AUTOCLEAR bit is enabled, the card reader will automatically clear track buffers after sending track data. Then the Host will not be able to get track data again.

If AUTOCLEAR bit is disabled, track data remain in buffer until track clear command is sent.

Response:

[CR][LF]

Example:

Command for set the AUTOCLEAR bit is enabled:

:	A	1	[CR]
3Ah	41h	31h	0Dh

Auto Send

Description:

This command sets AUTOSSEND bit. In case that the AUTOSSEND bit is enable, the card reader will automatically send track data as soon as card has been swiped.

Command:

Sb

Where:

b is the AUTOSSEND bit. The specifies values are as following:

Value	Auto Send
"0" (30h)	Disable
"1" (31h)	Enable

Response:

[CR][LF]

Example:

Command for set the AUTOSSEND bit is enabled:

:	S	1	[CR]
3Ah	53h	31h	0Dh

Auto Notify

Description:

This command sets AUTONOTIFY bit.

Command:

Nb

Where:

b is the AUTONOTIFY bit. The specifies values are as following:

Value	Auto Notify
“0” (30h)	Disable
“1” (31h)	Enable

Note: If AUTONOTIFY bit is enabled and AUTOSEND bit is disabled, the card reader will send the message “Card Inserted” as soon as card has been inserted and the message “Track Read” as soon as card has been read.

See “3.2.3 COMMUNICATION SEQUENCE – Mag Card Read Polling Sequence”.

Response:

[CR][LF]

Example:

Command for set the AUTONOTIFY bit is enabled:

:	N	1	[CR]
3Ah	4Eh	31h	0Dh

Response for the message as soon as card has been inserted:

C	a	r	d	_	l	n	s	e	r	t	e	d	[CR]	[LF]
43h	61h	72h	64h	20h	49h	6Eh	73h	65h	72h	74h	65h	64h	0Dh	0Ah

Response for the message as soon as card has been read:

T	r	a	c	k	_	R	e	a	d	[CR]	[LF]
54h	72h	61h	63h	6Bh	20h	52h	65h	61h	64h	0Dh	0Ah

3.3.2. STATUS COMMANDS

Send Reader Status

Description:

This command requests the reader to send the reader status, its configuration.

Command:

SR

Response:

SR:abcj.scnde.xyz.t.[SH][SL][CR][LF]

Where:

The reader status is as following:

Item	Description	Value
<i>a</i>	Card Load 1 signal	"0" (30h) = not detected "1" (31h) = detected
<i>b</i>	Card Load 2 signal	"0" (30h) = not detected "1" (31h) = detected
<i>c</i>	Card Load 3 signal	"0" (30h) = not detected "1" (31h) = detected
<i>i</i>	Card Inserted signal	"0" (30h) = not detected "1" (31h) = detected
<i>s</i>	AUTOSEND bit	"0" (30h) = disabled "1" (31h) = enabled
<i>c</i>	AUTOCLEAR bit	"0" (30h) = disabled "1" (31h) = enabled
<i>n</i>	AUTONOTIFY bit	"0" (30h) = disabled "1" (31h) = enabled
<i>d</i>	Track read direction	"0" (30h) = forward "1" (31h) = backward
<i>e</i>	Start/End character including in track data	"0" (30h) = not include "1" (31h) = include
<i>x</i>	Track #1 configuration	"0" (30h) = disabled "1" (31h) = enabled
<i>y</i>	Track #2 configuration	"0" (30h) = disabled "1" (31h) = enabled
<i>z</i>	Track #3 configuration	"0" (30h) = disabled "1" (31h) = enabled
<i>T</i>	Reader Type number	"0" (30h) to "6" (36h)

Example:

Command for the reader status:

:	S	R	[CR]
3Ah	53h	52h	0Dh

Response for the reader status:

S	R	:	1	0	1	1	.	1	1	0	1	1	.
53h	52h	3Ah	31h	30h	31h	31h	2Eh	31h	31h	30h	31h	31h	2Eh
1	1	0	.	3	.	E _[SH]	D _[SL]	[CR]	[LF]				
31h	31h	30h	2Eh	33h	2Eh	45h	44h	0Dh	0Ah				

- Card Load1 signal = detected
- Card Load2 signal = not detected
- Card Load3 signal = detected
- Card Inserted signal = detected
- AUTOSEND bit = enabled
- AUTOCLEAR bit = enabled
- AUTONOTIFY bit = disabled
- Track read direction = backward
- Start/End character including in track data = enabled
- Track #1 configuration = enabled
- Track #2 configuration = enabled
- Track #3 configuration = disabled
- Reader Type number = 3: Half/Full insertion (1 sensor in back)

Send Track Status

Description:

This command requests the reader to send the track status.

Command:

ST

Response:

ST:dsercc.dsercc.dsercc.[SH][SL][CR][LF]

Where:

First set of “dsercc” is for Track #1 status, second set is for Track #2, and Third set is Track #3.
The track status is as following:

Item	Description	Value
d	Data detection on track	“0” (30h) = not detected “1” (31h) = detected
s	Start character detection	“0” (30h) = not detected “1” (31h) = detected
e	End character detection	“0” (30h) = not detected “1” (31h) = detected
r	LRC error check results	“0” (30h) = passed “1” (31h) = error
cc	Two characters representing the hex value of byte count of track	“00” = 0 byte to “FF” = 255 bytes

Note: “CC” is RAW data length of magnetic card. NOT transmitted data on track.

Example:

Command for send the track status:

:	S	T	[CR]
3Ah	53h	54h	0Dh

Response for the track status: 78 bytes on Track #1, 19 bytes on Track #2 and 0 byte on Track #3

S	T	:	1	1	1	1	4	E	.	1	1	1	1
53h	54h	3Ah	31h	31h	31h	31h	34h	45h	2Eh	31h	31h	31h	31h
1	3	.	0	0	0	0	0	0	.	1 _[SH]	0 _[SL]	[CR]	[LF]
31h	33h	2Eh	30h	30h	30h	30h	30h	30h	2Eh	31h	30h	0Dh	0Ah