



Chipsmall Limited consists of a professional team with an average of over 10 year of expertise in the distribution of electronic components. Based in Hongkong, we have already established firm and mutual-benefit business relationships with customers from,Europe,America and south Asia,supplying obsolete and hard-to-find components to meet their specific needs.

With the principle of “Quality Parts,Customers Priority,Honest Operation,and Considerate Service”,our business mainly focus on the distribution of electronic components. Line cards we deal with include Microchip,ALPS,ROHM,Xilinx,Pulse,ON,Everlight and Freescale. Main products comprise IC,Modules,Potentiometer,IC Socket,Relay,Connector.Our parts cover such applications as commercial,industrial, and automotives areas.

We are looking forward to setting up business relationship with you and hope to provide you with the best service and solution. Let us make a better world for our industry!



Contact us

Tel: +86-755-8981 8866 Fax: +86-755-8427 6832

Email & Skype: info@chipsmall.com Web: www.chipsmall.com

Address: A1208, Overseas Decoration Building, #122 Zhenhua RD., Futian, Shenzhen, China



Spec : MIS-DG60B115

SPECIFICATION
FOR
MAGNETIC CARD READER
(Manual Insertion type)
WITH
RS-232C Interface
Z U - 1 8 9 0 M R 0 2

SEP. 2003

MATSUSHITA ELECTRIC INDUSTRIAL CO., LTD.

MATSUSHITA INDUSTRIAL EQUIPMENT CO., LTD.

REVISED RECORD

Date	Document No.	Contents of revision	Page

CONTENTS

1. INTRODUCTION	-----	1
2. PRODUCT NAME	-----	1
3. FUNCTION	-----	1
4. EQUIPMENT SPECIFICATION	-----	1
5. CARD STANDARD	-----	2
6. CIRCUIT CONSTRUCTION	-----	3
7. ENVIRONMENTAL CHARACTERISTICS	-----	4
8. HOST RS 232 COMMANDS	-----	4
9. ERROR HANDLING	-----	7
10. UNIT LIFE AND RELIABILITY	-----	8
11. MAINTENANCE	-----	8
12. CAUTION ON THE USE	-----	9
13. APPEARANCE	-----	10

1. INTRODUCTION

This specification describes manual insertion type magnetic card reader with built in RS232 interface and decoder on single board.

2. PRODUCT NAME

- 2.1 Product Name : Manual Insertion type magnetic card reader w/ built-in RS-232
(Full insertion type)
- 2.2 Model No. : ZU-1890MR02

3. FUNCTION

- 3.1 Card operation : Insertion & Ejection
- 3.2 Read/Write : Read only
- 3.3 Read direction : Ejection (Backward)

4. EQUIPMENT SPECIFICATION

- 4.1 Card operating speed : 10 cm/s ~ 120 cm/s
- 4.2 Out dimension : (W) 101.6 mm X (D) 112.6 mm X (H) 76.2 mm
- 4.3 Weight : Approximately 120 g
- 4.4 Supplied voltage
- (1) Supplied voltage : DC 5 V \pm 0.5V
Ripple(Less than 50 mVp.p)
- (2) Current consumption : Approx. 30 mA
- (3) Connector : Molex 53261-0590
- 4.5 Environment requirements : At indoor

5. CARD STANDARD

5.1 Card standard

Card Standard	ISO 1	ISO 2
	Track 1st	Track 2nd
Recording density	210 BPI	75 BPI
Recording capacity	79 Characters (7 bit code)	40 Characters (5 bit code)
Recording method	F2F	F2F

5.2 Location of tracks

ISO (2 Tracks)ISO 7810, ISO 7811

Coercive force(Hc): $2.4 \times 10^4 \text{ A/m} \sim 2.4 \times 10^5 \text{ A/m}$
(300 Oe to 3000 Oe)

(unit mm)

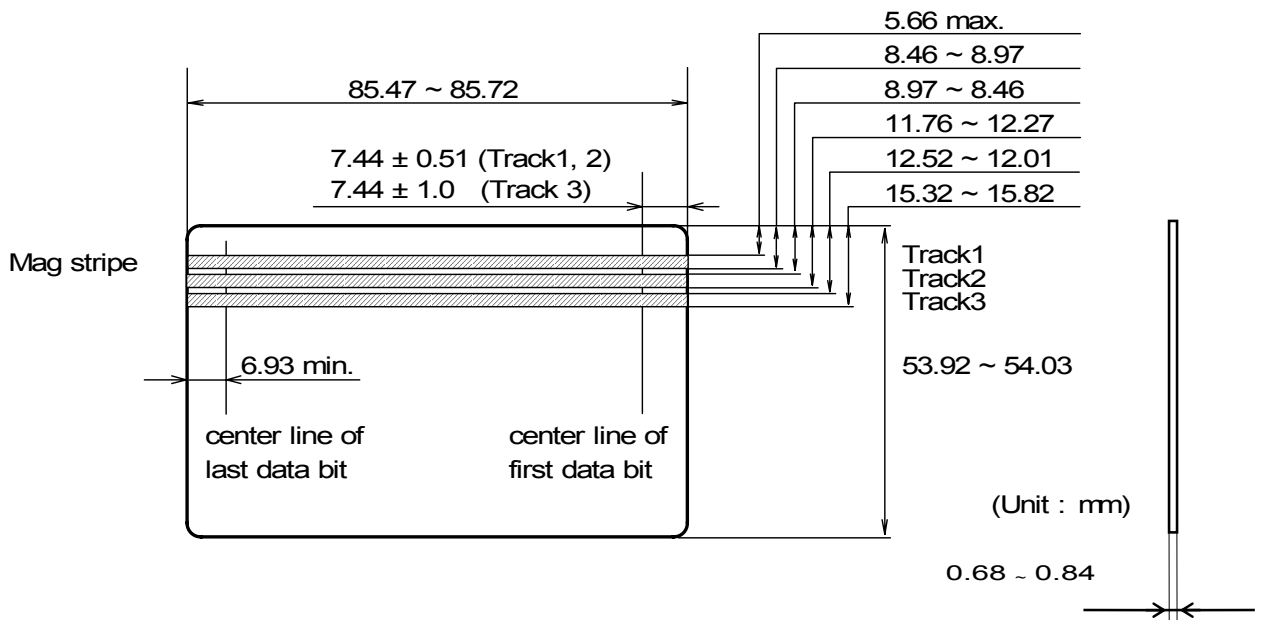
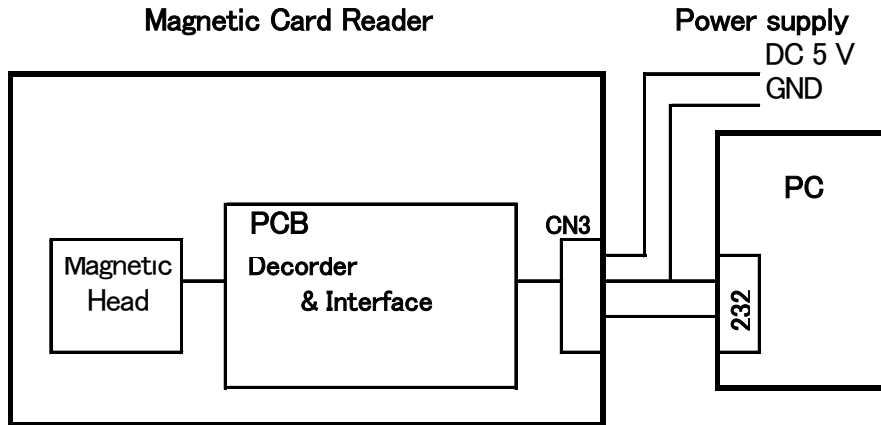

Figure 6.2 Location of Tracks

6. CIRCUIT CONSTRUCTION

6.1 Block diagram



6.2 Card Reader connector

- (1) Connector Name: CN3
- (2) Model No. : Molex 53261-0590
- (3) Pin No. & Signal Name :

Card Reader Side (CN2) Pin No.	RS232 Signal Name	Connection to external equipment
5	DC 5 V	DC power supply
4	DC 5 V	
3	TX	PC
2	RX	PC
1	GND	DC power supply & PC

(Ref.) Receptacle: Molex 51021-0500
Terminal : Molex 50079-8000

7. ENVIRONMENTAL CHARACTERISTICS

7.1 Operating temperature Range : -10 °C ~ +50 °C

7.2 Operating humidity Range : 10 % ~ 90 % RH (No condensation allowed)

7.3 Storage temperature Range : -20 °C ~ +60 °C

7.4 Storage humidity Range : 10 % ~ 95 %RH(No condensation allowed)
(24hours)

* Test procedure : Place the card reader in the standard environment (temperature: 20 °C ± 5 °C, humidity: 35 % ~ 60 %RH). Leave it for 12 hours, and measure the functions. Make sure no abnormality is found.

7.5 Vibration : Vibration sweep 10 Hz/m ~ 50 Hz/m
X,Y,Z directions

7.6 Shock durability : 294 m/s² (30 G)

7.7 Others : Make sure any source of noise that may deteriorate the characteristics of the card reader is not present around the card reader.

8. HOST RS 232 COMMANDS

8.1 General Description

All command strings begin with a “:” as shown and end with [CR] (not shown)

[CR] = ASCII carriage return character, 0DH.

[LF] = ASCII line feed character, 0AH.

<sh> = high digit of 8 bit hexadecimal checksum

<sl> = low digit of 8 bit hexadecimal checksum

Mode : Polling mode

Auto Send Mode (default)

Configuration – Saved in EEPROM.

8.2 Configuration Commands

:Bx - Change Baud rate x=3-> 9600, x=4->19200

:EtB - Enable/disable track reading 't' where t = 1 to 3 b=0 means disable, b=1 means enable

:X1 - Read direction: reverse

:Ab - Auto clear bit, if b=0 disable, if b=1 enable

if Autoclear = 1, the card reader will automatically clear track buffers after sending track data, user will NOT be able to poll data again.

if Autoclear = 0, data will remain in buffer until track clear command is sent.

:Sb - Auto send bit, if b=0 disable, if b=1 enable

if Autosend = 1, the card reader will automatically send track data as soon as card has been

swiped, user does not have to poll data.

:Nb - Auto notify bit, if b=0 disable, if b=1 enable

if Autonotify = 1 and Autosend=0, the card reader will send the message "TRACK READ" as soon as the card has been swiped. The user can then poll the data with :Tn command.

:Jb - Include start (%) and end (?) characters in track data, if b=0 disable, if b=1 enable

:RT3 - Select Reader type (determines which card load signals to use)

3= Half/Full insertion using only 1 sensor in back,
Returns: reader status

8.3 Status Commands

:SR - Send reader status, its configuration

Returns: SR:ABCI.scnde.xyz.t.<sh><sl><CR><LF>

Where:

A=CardLoad1 signal = 0 or 1

B=CardLoad2 signal = 0 or 1

C=CardLoad3 signal = 0 or 1

I=CardInserted signal = 0 or 1

s=AutoSend configuration bit = 0 or 1

c=AutoClear configuration bit = 0 or 1

n=AutoNotify configuration bit = 0 or 1

d=direction configuration bit = 0 or 1 (1 = reverse)

e=UseStartEnd configuration bit = 0 or 1

x=Track 1 enable bit = 0 or 1 (1=enabled)

x=Track 2 enable bit = 0 or 1 (1=enabled)

x=Track 3 enable bit = 0 or 1 (1=enabled)

t=Reader Type character = 0,1,2,3 see RT command

:ST - Send track status

Returns: ST:dsercc.dsercc.dsercc.<sh><sl><CR><LF>

Where:

d= data was detected on track

s= start character was detected

e = end character was detected

r = LRC check was passed

cc = two characters representing the hex value of byte count of track.

First set of "dsercc" is for track 1, second set is for track 2, and third set is for track 3.

:V - Send Firmware Version

Returns: PANASONIC MIECOA UCI-MAG vx.xx Copyright xxxx

8.4 Track Data Commands

- :CA - Clear All tracks

- :TA - Transmit All tracks (1,2,3)
 - same as sending :T1, :T2, :T3 in sequence
 - note: track data will only be send if the track enable bit for that particular track is set

- :Tt - Transmit track 't' data buffer in ASCII
 - where t = 1,2, or 3 for the track number
 - Example Returns: T1:%1234567890?.<sh><sl><CR><LF>
 - If there is an LRC error in the track data a:
T1:error. <sh><sl><CR><LF>

- :Ct - Clear track t

8.5 Reset Command

- :RX - Reset System

8.6 Default settings

- Firmware Version = PANASONIC MIECOA UCI-MAG v3.04 Copyright 1999
- Baud Rate = 9600BPS , no parity, 8 data bits, 1 stop bit
- Reader Type = 3 (Half/Full insertion, Reverse read)
- Read Direction = 1 (Backward)
- Track 1 = Enabled
- Track 2 = Enabled
- Track 3 = Disabled
- AutoNotify = FALSE
- AutoSend = TRUE
 - The card reader will automatically send track data as soon as card has been swiped, user does not have to poll data.
- AutoClear = TRUE
 - The card reader will automatically clear track buffers after sending track data, user will NOT be able to poll data again.
- Include Start & End = TRUE

9. ERROR HANDLING

9.1 Magnetic Card Read Errors

If a card read is bad no data (Tx:error.<sh><sl><CR><LF>) will be returned when track data is requested with the T1, T2, T3, or TA commands.

If AutoClear = 0 when the :SR command will return the status of the most recent card swipe. The status return string contains data on Missing STX, ETX, and LRC errors for each track. Please see the details of the :SR command in the preceding section.

9.2 Communication Errors

The card reader will acknowledge most RS232 commands with either a data string or <CR>. Please see preceding section for details. If the card reader fails to receive the command correctly it will not respond. The Host PC control software should assume that if no response is received in 1 second a communication error has occurred and the command should be resent.

<Calculating Procedure of checksums>

Example) In case that a return data is "SE:400000030000".

1st step) $S(53h)+E(45h)+:(3Ah)+4(34h)+0(30h)+0(30h)+0(30h)+0(30h)+0(30h)+0(30h)+3(33h)+0(30h)+0(30h)+0(30h)+0(30h) = 319h$

2nd step) Neglect 3 (upper byte of 319h).

3rd step) Calculate the two's complement value of 19h (lower byte of 319h).

$100h-19h = E7h$ (E7 is the two's complement value of 19h.)

Consequently sh is 45h ("E") and sl is 37h ("7").

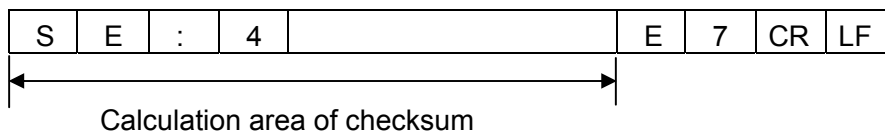

9.3 Power Failure

If power fails and is then restored, the unit is reset and reinitialized. On reset the card reader will send the current firmware revision. In this way a host PC can tell when power has been lost on the card reader.

10. UNIT LIFE AND RELIABILITY

10.1 Life

Magnetic head : 300,000 times pass (2 passes / operation)
(conditions) In a clean office room. In damp or dirty atmosphere, the life may be 1/3 to 1/5 of the above figure.

10.2 Error rate : Less than 0.1 %

(conditions) This error rate is obtained when a new normal card(data "1010xxx) is horizontally passed at the standard speed (30 cm/s ~ 60 cm/s) by manual operation in the clean environment at delivery from our company.

11. MAINTENANCE

Because of difficulty in changing components on the P.C Board, replacement of whole unit is recommended for service and maintenance.

12. CAUTIONS ON USE

Please be noted that we do not guarantee proper performance of the card reader if it is used other than the indicated specification range.

12.1 During installation

- (1) Do not drop or bump anything against the card reader. Otherwise, failure may be the result.
- (2) Do not touch the P.C.B. with bare hands.
- (3) Be sure to install on a flat surface so as to prevent any force to be applied to the card reader during installation.
- (4) Avoid installing the Card Reader in the following environment.
 - * Watery, humid or dusty place.
 - * Near machines which generate magnetic field or inducted noise. (Printer, LED display, CRT etc.)
 - * Place which gets direct sunlight.

In the case that the card readers are used in the environment full of dust etc., the life time of the magnetic head and mechanism for transferring cards will decrease.

12.2 During use

- (1) Be sure to use a card which conforms to ISO standard. Anti-magnetic of the applied card should be 2.4×10^4 A/m to 2.4×10^5 A/m of ISO standard.
- (2) Card operation speed should be within the specification range. Forced stop or change of speed during the card operation may cause a read error. Appropriate speed to maintain stable operation is 30 cm/s to 60 cm/s.
- (3) Store the card with caution to prevent dirt, scratch and distortion. No foreign matter should be stuck on the magnetic stripe surface. Use of such card may result in a read error.
- (4) Insert a cleaning card and clean the head periodically to prevent wearing of the magnetic head. Head cleaning using the cleaning card should be performed about once a week if the room is not dusty.
- (5) Environment conditions such as external noise or electrostatics etc. may affect operation of the card reader and interface. Check the level of noise resistance and electrostatic resistance of your factory before using the card reader.

13. APPEARANCE

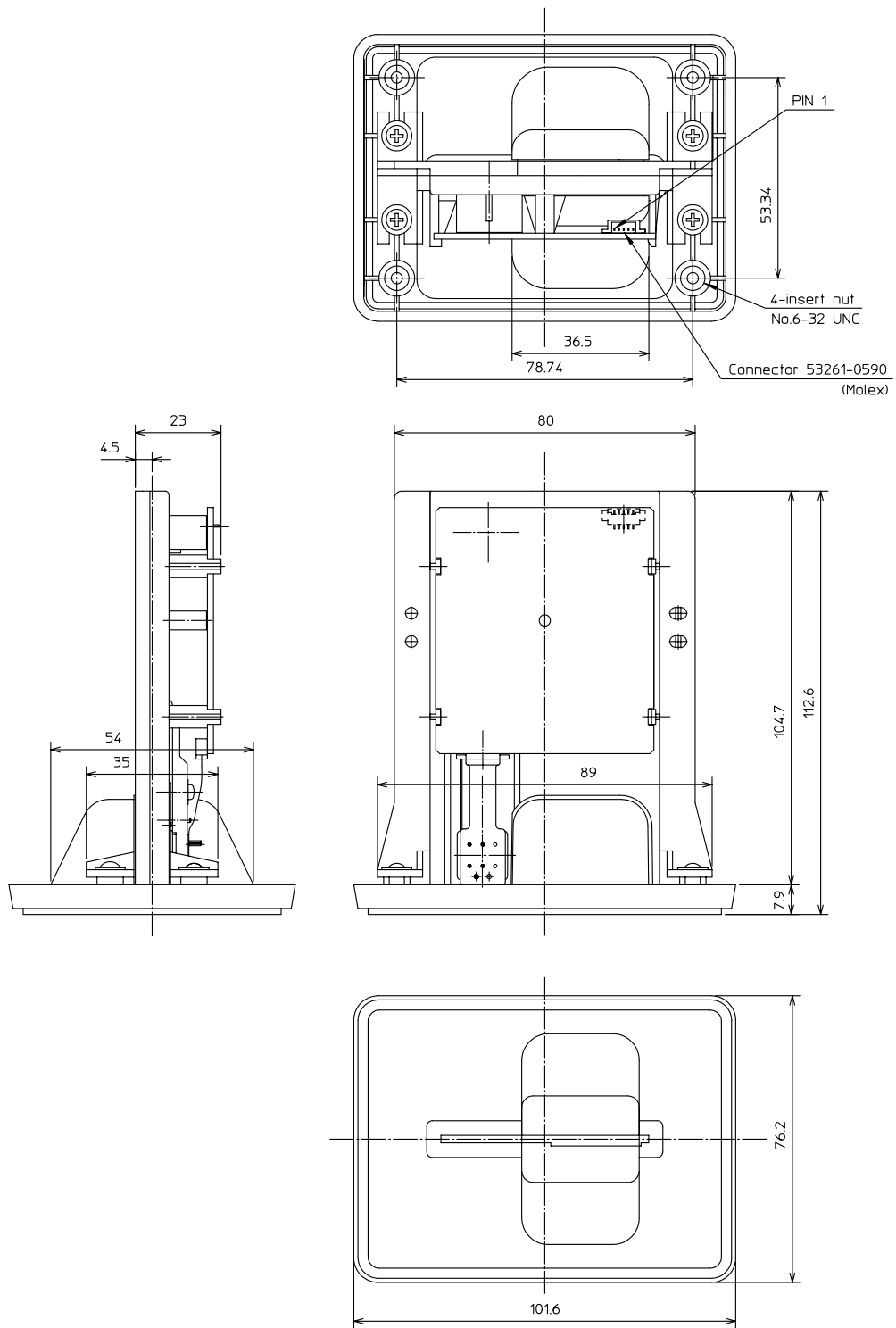

General Tolerance ± 0.5

Unit : mm