



Chipsmall Limited consists of a professional team with an average of over 10 year of expertise in the distribution of electronic components. Based in Hongkong, we have already established firm and mutual-benefit business relationships with customers from,Europe,America and south Asia,supplying obsolete and hard-to-find components to meet their specific needs.

With the principle of “Quality Parts,Customers Priority,Honest Operation,and Considerate Service”,our business mainly focus on the distribution of electronic components. Line cards we deal with include Microchip,ALPS,ROHM,Xilinx,Pulse,ON,Everlight and Freescale. Main products comprise IC,Modules,Potentiometer,IC Socket,Relay,Connector.Our parts cover such applications as commercial,industrial, and automotives areas.

We are looking forward to setting up business relationship with you and hope to provide you with the best service and solution. Let us make a better world for our industry!



## Contact us

Tel: +86-755-8981 8866 Fax: +86-755-8427 6832

Email & Skype: info@chipsmall.com Web: www.chipsmall.com

Address: A1208, Overseas Decoration Building, #122 Zhenhua RD., Futian, Shenzhen, China



SPEC.No. • MES-DG60B083

SPECIFICATION  
FOR  
MAGNETIC CARD READER  
(Manual Insertion ••type)

ZU-M2121S453  
••

FEB . 2001

MATSUSHITA ELECTRIC INDUSTRIAL CO., LTD.

MATSUSHITA INDUSTRIAL EQUIPMENT CO., LTD.  
OSAKA •• JAPAN

## CONTENTS

1. INTRODUCTION	1
2. PRODUCT NAME	1
3. FUNCTION	1
4. EQUIPMENT SPECIFICATION	1
5. CARD STANDARD	2
6. CIRCUIT CONSTRUCTION	3
7. ENVIRONMENTAL CHARACTERISTICS	5
8. UNIT LIFE	6
9. GUARANTEE	6
10. MAINTENANCE	6
11. CAUTIONS ON THE USE	6
12. APPEARANCE	8

## 1. INTRODUCTION

This specification describes about manual Insertion type magnetic card reader, featuring small size, light weight and high performance which enable to read card data encoded by following ISO 2 standards.

## 2. PRODUCT NAME

- 2.1 Product Name • • Manual Insertion type magnetic card reader
- 2.2 Model No. • • ZU-M2121S453

## 3. FUNCTION

- 3.1 Card operation • • One way,insertion••
- 3.2 Read/Write • • Read only

## 4. EQUIPMENT SPECIFICATION

- 4.1 Card operating speed • • 40 cm/s • • 120 cm/s
- 4.2 Out dimension • • (W) 75 mm • (D) 92 mm • (H) 28 mm
- 4.3 Mass • • Approximately 55 • •
- 4.4 Supplied voltage
  - (1) Supplied voltage(DC) • • DC 5 V (tolerance  $\pm 0.5$  V) / Ripple (Less than 50 mV p-p)
  - (2) Current consumption • • TYP. 20 mA, MAX. 25 mA
  - (3) Absolute maximum applied voltage • • DC 7 V
- 4.5 Connector • • JAE IL-7P-S3FP2 (Refer to 6.5)
- 4.6 Environment requirement • • At indoor

••

## 5. CARD STANDARD

### 5.1 Card standard

Materials and dimensions of the card should be submitted to ISO standards. But defined items in this specification are prior to these standards.

Table 5.1 Card standard

Card Standard	ISO7810, ISO7811
	Track 2 <sup>nd</sup>
Recording density	75 BPI
Recording capacity	23 Characters ( 5 bit code)
Recording method	F2F

Note: Start sentinel, End sentinel and LRC are Included in the recording capacity.

### 5.2 Location of tracks

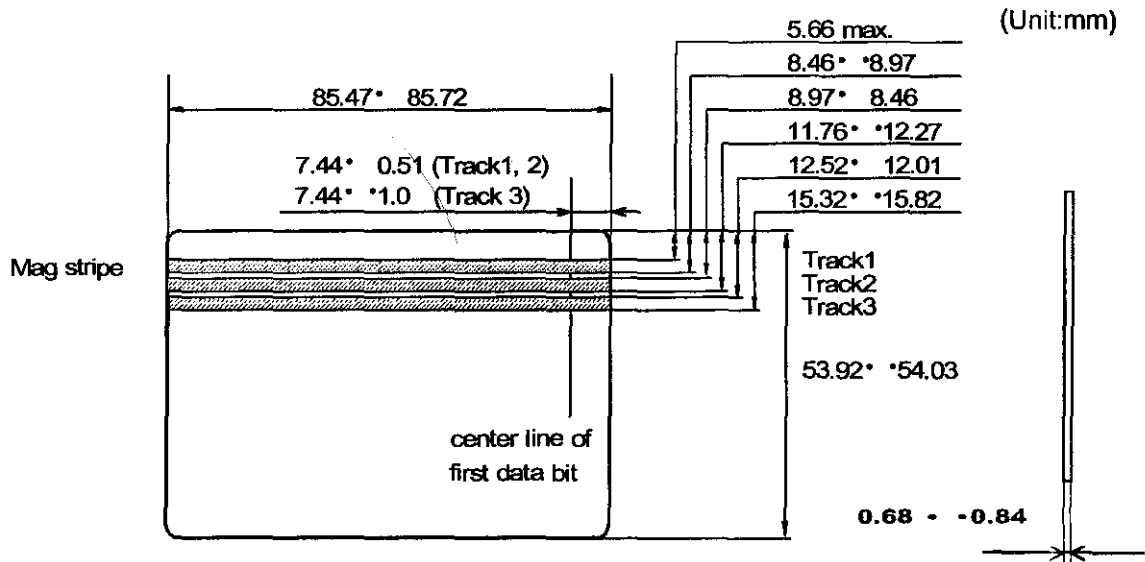

Figure 6.2 Location of Tracks

### 5.3 Physical characteristics

- (1) Thickness : 0.76 mm (tolerance  $\pm 0.08$  mm)
- (2) Card Warpage : 2.5 mm max.  
(include relief height of embossed characters)

### 5.4 Magnetic characteristics

- (1) Coercive force (Hc) :  $2.4 \cdot 10^4$  A/m  $\cdot 2.4 \cdot 10^4$  A/m
- (2) Residual flux ( $\cdot r$ ) :  $1.25 \times 10^{-8}$  Weber/cm (tolerance  $\pm 0.15 \times 10^{-8}$  Weber/cm)
- (3) Squareness ratio : More than 0.70  
( $\cdot r/\cdot m$ )

## 6. CIRCUIT CONSTRUCTION

### 6.1 Block diagram

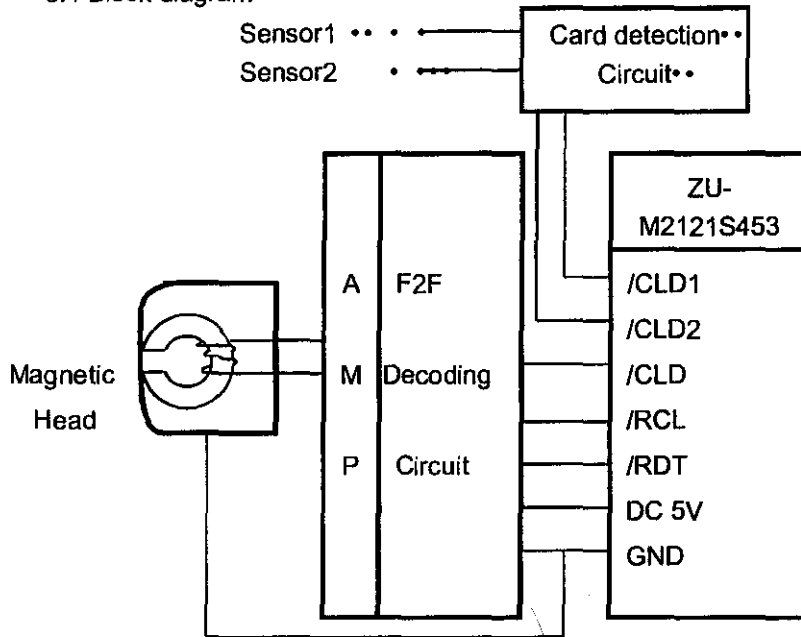

Fig 6.1 •• Block diagram ••

••

### 6.2 Interface requirement

- (1) Signal Level •• CMOS level
- (2) Signal Logic •• Low active••
- (3) Connection condition••

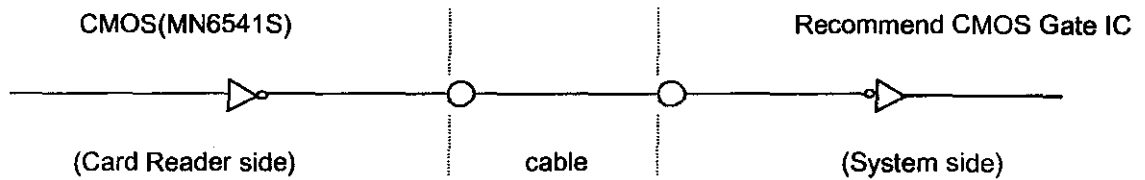

Fig 6.2 Connection of output circuit

### (4) Output voltage

Table 7.2 Output voltage

	Min(V)	Max(V)	Conditions
H level •• "0"••	4.0	V <sub>cc</sub>	I <sub>...=</sub> -1.0 mA
L level •• "1"••	-	0.4	I <sub>...=</sub> 4.0 mA

### 6.3 Explanation of input/output signal

- (1) /CLD2(CARD LOAD): The /CLD2 line will be Low when a Magnetic Card is inserted in the . . . . .  
. . . . . end of Magnetic Card Reader.  
The /CLD2 line will be High at all other times.
- (2) /CLD1(CARD LOAD): The /CLD1 line will be Low when a Magnetic Card inserts in the  
Magnetic Card Reader.  
The /CLD1 line will be High at all other times.
- (3) /CLD (CARD LOAD): When the /CLD line will be Low when a encoded Magnetic Card inserts  
in the Magnetic Card Reader, and when a encoded Magnetic Card  
inserts in the end of Magnetic Card Reader the /CLD line will be high.
- (4) /RCL(READ CLOCK): This is used to sample the data line by it's falling edges.  
The time relationship of the clock with respect to the order signals is  
shown in Figure 6.4.
- (5) /RDT(READ DATA): At the moment /RCL change from High to Low ; /RDT is "1" when  
the /RDT line is Low , and /RDT is "0" when the /RDT line is High.

### 6.4 Output signal timing chart

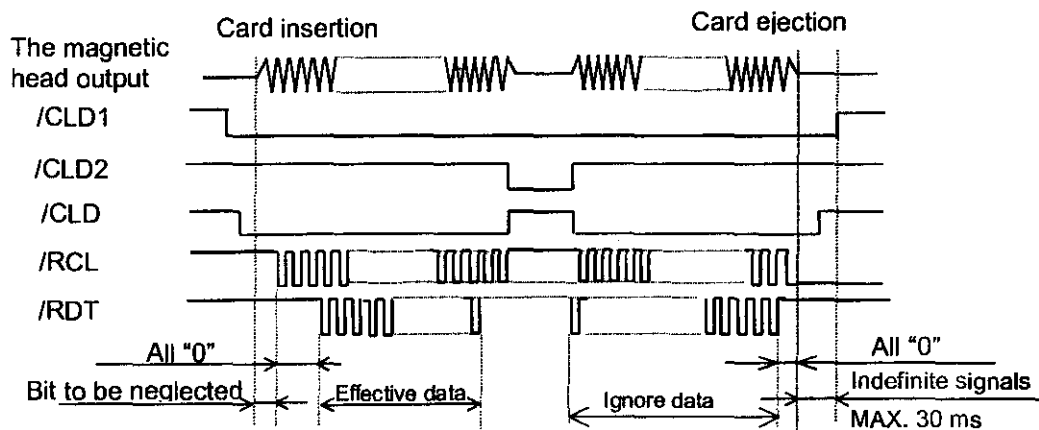

### /RCL & /RDT Detail timing chart

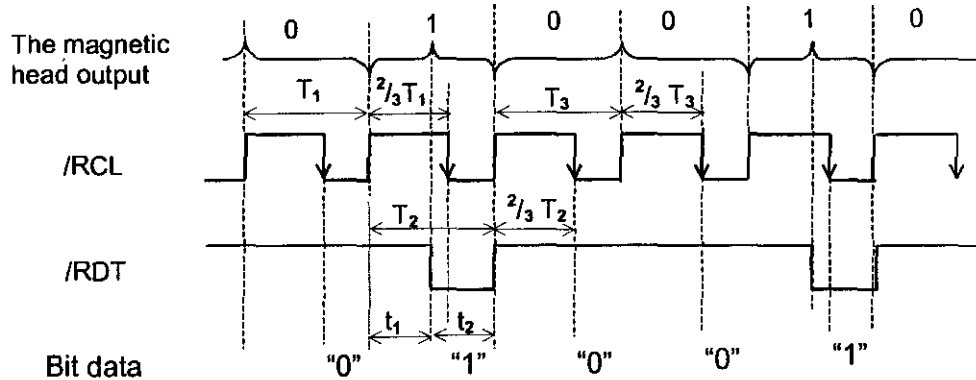

Fig 6.4 Timing sequence(Detail)

When the jitter of the magnetic head output is 0 % , the following equation is satisfied.

$$T=T_1=T_2=T_3, \quad t_1=t_2$$

$$T(s) = \frac{2.54 \text{ cm/inch}}{\text{Recording density (BPI)}} \cdot \frac{1}{\text{Card speed (cm/s)}}$$

6.5 Terminal No. of connector

- (1) Maker : JAE (Japan Aviation Electronics Industry , Limited.)
- (2) Model No : IL-7P-S3FP2
- (3) Pin No. & Signal Name

..... (Card reader side)

Connector Pin No.	Signal Name
1	DC 5V
2••	/RDT••
3	/RCL
4	/CLD
5••	/CLD1
6	/CLD2••
7	GND

(Note) : Cable length shall be less than 300 mm.

7. ENVIRONMENTAL CHARACTERISTICS

7.1 Operating temperature Range : -20 • • ~ 60 • • • •

7.2 Operating humidity Range : 10 % ~ 90 % RH (No condensation allowed)

7.3 Storage temperature Range : -30 • • ~ 70 • • •

7.4 Storage humidity Range : 10 % ~ 95 % RH (No condensation allowed) • • 24 hours • • •

Remarks: Place the card reader in the standard environment (temperature: 20 • • • • 5 • • ; humidity: 35 • • ~ 60 % RH).

Leave it for 12 hours, and measure the functions. Make sure no abnormality is found.

7.5 Vibration : Vibration sweep 10 Hz ~ 50 Hz , sweep 0.5 oct/min, X,Y,Z directions : 10 m/s<sup>2</sup>

7.6 Shock durability : 294 m/s ( 30 G)

7.7 Others : Make sure any source of noise that may deteriorate the characteristics of the card reader is not present around the card reader.



## 8. UNIT LIFE

Life Magnetic head : 300,000 operation

(conditions) In a clean office room. In damp or dirty atmosphere, the life may be 1/3 to 1/5 of the above figure.

## 9. GUARANTEE

If defects should occur within one year after the delivery of the card reader due to improper material or bad workmanship, the defective parts shall be replaced or repaired, free of charge.

## 10. MAINTENANCE

Because of difficulty in changing components on the P.C Board, replacement of whole unit is recommended for service and maintenance.

## 11. CAUTIONS ON THE USE

Please be noted that we do not guarantee proper performance of the card reader if it is used other than the indicated specification range.

### 11.1 At the installation

- (1) Do not drop or bump anything against a card reader. Otherwise, failure may be the result.
- (2) Do not touch the P.C.B. with bare hands.
- (3) Be sure to install on a flat surface so as to prevent any force to be applied to the Card reader at the installation.
- (4) Be sure not to touch the protection cover on the P.C.B at installation so the magnetic head will move correctly.
- (5) The card reader should avoid installation of the following environment.
  - • Watery, humid or dusty place.
  - • Near machines which generate magnetic field or inducted noise.  
(Printer, LED display, CRT etc.)
  - • Place which gets direct sunlight

## 11.2 At the use

- (1) Be sure to use a card which conforms ISO standard.
- (2) Card operation speed should be within the specification range.  
Forced stop or change of speed during the card operation may cause a read error.  
Appropriate speed to maintain stable operation is 30 cm/s • •60 cm/s.
- (3) Store the card with caution to prevent dirt, scratch and distortion.  
Especially, no foreign matter shall be stuck on the magnetic stripe surface.  
Use of such card may result in a read error.
- (4) Insert a cleaning card and clean the head periodically to prevent wearing of the magnetic head.  
Head cleaning using the cleaning card should be performed about once a week if the room is not dusty.
- (5) Depends on installation environment (incorporation condition) or operation condition, external noise or electrostatics and so on may affect the machine, and which may cause an error or a wrong operation.  
Check the level of noise resistance and electrostatic resistance of your factory before using the card reader.

12. APPEARANCE

