



Chipsmall Limited consists of a professional team with an average of over 10 year of expertise in the distribution of electronic components. Based in Hongkong, we have already established firm and mutual-benefit business relationships with customers from,Europe,America and south Asia,supplying obsolete and hard-to-find components to meet their specific needs.

With the principle of “Quality Parts,Customers Priority,Honest Operation,and Considerate Service”,our business mainly focus on the distribution of electronic components. Line cards we deal with include Microchip,ALPS,ROHM,Xilinx,Pulse,ON,Everlight and Freescale. Main products comprise IC,Modules,Potentiometer,IC Socket,Relay,Connector.Our parts cover such applications as commercial,industrial, and automotives areas.

We are looking forward to setting up business relationship with you and hope to provide you with the best service and solution. Let us make a better world for our industry!



Contact us

Tel: +86-755-8981 8866 Fax: +86-755-8427 6832

Email & Skype: info@chipsmall.com Web: www.chipsmall.com

Address: A1208, Overseas Decoration Building, #122 Zhenhua RD., Futian, Shenzhen, China



Brief Description

The ZWIR4512 enables secure low-power wireless IPv6 communication for sensors and small devices. IDT provides a user-programmable, royalty-free 6LoWPAN stack with mesh routing capability with the ZWIR4512. 6LoWPAN is an Internet Engineering Task Force (IETF) standard for building wireless, low-power IP-based sensor and device networks. These networks can easily be integrated into existing IT infrastructure or operate autonomously.

Secure communication is provided by standard-compliant implementations of the Internet Protocol Security (IPSec) protocol suite and the Internet Key Exchange Protocol version 2 (IKEv2), which enable highly secure end-to-end communication, including over unsecure network nodes.

The module is powered by an ARM[®] Cortex[™]-M3 (ARM, Ltd. trademark) microcontroller and provides a rich set of GPIO and peripheral interfaces. Up to 192kB of flash and 32kB of RAM are available for applications. Different low power modes are provided to save energy in battery-operated devices. The modules provide superior radio properties without the need for complicated external RF design.

Benefits

- Uniquely simple programmability
- Standard-compliant security solution
- No need for external microcontroller
- Plug-and-play integration into local and wide-area networks
- No RF design required
- 2D barcode label containing MAC address
- Superior radio propagation
- ETSI/FCC certified

Typical ZWIR4512 Application Setup

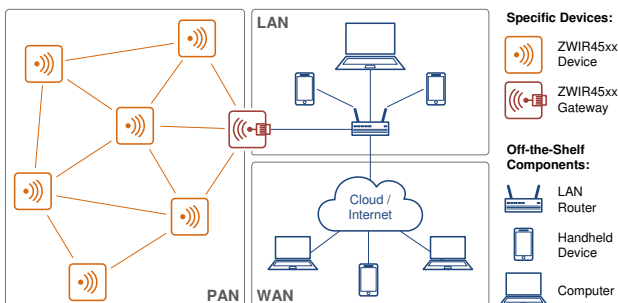

Hardware Features

- License-free 868/915 MHz frequency bands
- ARM[®] Cortex[™]-M3 32-bit microcontroller
- ≤192kB flash and 32kB RAM for user applications
- Unique EUI64 address
- 4 channels in EU mode; 10 channels in US mode
- 19 (ZWIR4512AC1) or 21 (ZWIR4512AC2) GPIOs with multiplexed peripheral functions:
 - 2 x UART, SPI, 3 x ADC, 2 x DAC, 11 x PWM, USB, CAN, I²C[™] (NXP trademark), 8 x timer
 - Several 5V tolerant I/Os available
- Low current consumption: 3.5 μA in Standby Mode; 10.5 mA in Receive Mode; 16.0 mA in Transmit Mode @ 0 dBm
- Modulation schemes
 - BPSK (20 kbps EU, 40 kbps US)
 - O-QPSK (100 kbps EU, 250 kbps US)
- Receiver sensitivity: up to -110 dBm
- TX output power: up to 10 dBm (US Mode)

Firmware Features

- Serial command interface with built-in security and over-the-air update (OTA) functionality
- Royalty-free library bundle for custom firmware: 6LoWPAN communication library with mesh routing capability; IPSec and IKEv2 security libraries; over-the-air update library; several peripheral libraries

Available Support

- Development Kit
- Programming guide and application notes
- Ethernet, USB and UART gateways
- Free packet sniffer and example programs demonstrating C-API usage
- Windows[®] (Microsoft Corp. trademark) and Linux[®] (Linus Torvalds trademark) support tools

Physical Characteristics

- Supply voltage: 2.0 V to 3.6 V
- Operating temperature: -40 °C to +85 °C
- 30-pin edge-board contact package or 32-pin land grid array package

Stack Architecture

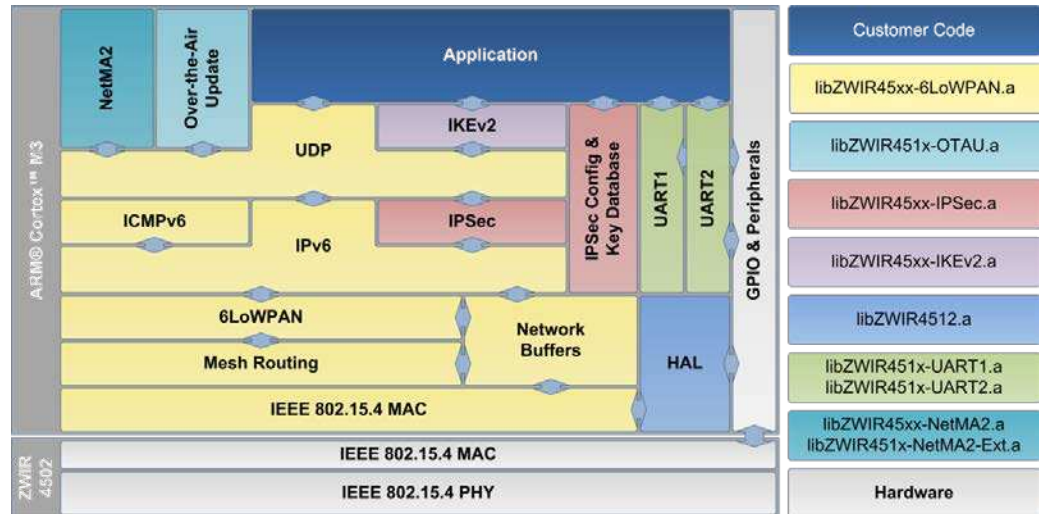

Applications

The ZWIR4512 serves as a universal secure radio communication module. Typical applications include home and industry automation, health monitoring, smart metering / smart grid applications, and key-less entry systems.

Its very low current consumption makes the module suitable for battery-operated devices.

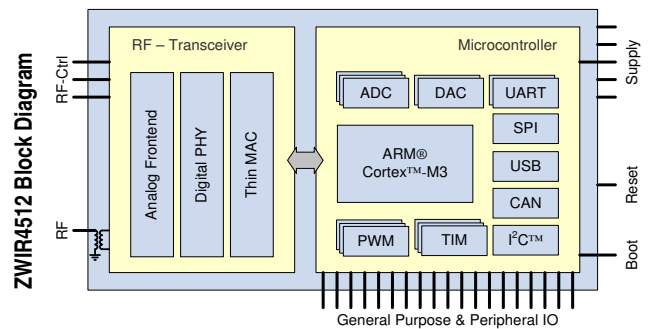

Ordering Information

Product Sales Code	Description	Package
ZWIR4512AC1xA	Unprogrammed module for user application programs	30 pin SMT, 27.9 mm x 16.5 mm
ZWIR4512AC1xI	Preprogrammed module with serial command interface	30 pin SMT, 27.9 mm x 16.5 mm
ZWIR4512AC2xA	Unprogrammed module for user application programs	32 pin LGA, 23.1 mm x 15.1 mm
ZWIR4512AC2xI	Preprogrammed module with serial command interface	32 pin LGA, 23.1 mm x 15.1 mm
ZWIR4512-Devkit	Development Kit	



Corporate Headquarters
6024 Silver Creek Valley Road
San Jose, CA 95138
www.IDT.com

Sales
1-800-345-7015 or 408-284-8200
Fax: 408-284-2775
www.IDT.com/go/sales

Tech Support
www.IDT.com/go/support

DISCLAIMER Integrated Device Technology, Inc. (IDT) reserves the right to modify the products and/or specifications described herein at any time, without notice, at IDT's sole discretion. Performance specifications and operating parameters of the described products are determined in an independent state and are not guaranteed to perform the same way when installed in customer products. The information contained herein is provided without representation or warranty of any kind, whether express or implied, including, but not limited to, the suitability of IDT's products for any particular purpose, an implied warranty of merchantability, or non-infringement of the intellectual property rights of others. This document is presented only as a guide and does not convey any license under intellectual property rights of IDT or any third parties.

IDT's products are not intended for use in applications involving extreme environmental conditions or in life support systems or similar devices where the failure or malfunction of an IDT product can be reasonably expected to significantly affect the health or safety of users. Anyone using an IDT product in such a manner does so at their own risk, absent an express, written agreement by IDT.

Integrated Device Technology, IDT and the IDT logo are trademarks or registered trademarks of IDT and its subsidiaries in the United States and other countries. Other trademarks used herein are the property of IDT or their respective third party owners. For datasheet type definitions and a glossary of common terms, visit www.idt.com/go/glossary. All contents of this document are copyright of Integrated Device Technology, Inc. All rights reserved.

Contents

1	Module Characteristics	5
1.1.	Absolute Maximum Ratings	5
1.1.1.	Voltage Characteristics	5
1.1.2.	Current Characteristics	5
1.1.3.	Thermal Characteristics	5
1.2.	Operating Conditions	5
1.2.1.	General Operating Conditions	5
1.2.2.	Current Consumption per Operating Mode.....	7
2	Module Description.....	7
2.1.	Radio Transceiver	8
2.2.	Microcontroller	8
2.2.1.	MCU Core	8
2.2.2.	Peripherals and Interfaces	8
2.2.3.	Programming and Debugging	8
2.3.	Firmware.....	9
2.3.1.	Serial Command Interface (SCI) Firmware.....	9
2.3.2.	C Application Programming Interface (C-API)	9
2.4.	Power Modes.....	9
2.4.1.	Run Mode.....	10
2.4.2.	Sleep Mode	10
2.4.3.	Stop Mode.....	10
2.4.4.	Standby Mode	10
3	Application Circuits.....	11
3.1.	Power Supply.....	11
3.2.	Reset and Boot Select.....	12
3.3.	Debug Access.....	12
3.4.	Antenna	13
4	Pinout	14
5	Package Dimensions and PCB Footprints	21
5.1.	ZWIR4512AC1.....	21
5.2.	ZWIR4512AC2.....	22
6	Soldering Information	23
7	Customization.....	24
8	Certification.....	24
8.1.	European R&TTE Directive Statements.....	24
8.2.	Federal Communication Commission Certification Statements	24
8.2.1.	Statements	24

8.2.2. Requirements.....	25
8.3. Supported Antennas.....	25
9 Ordering Information.....	25
10 Related Documents.....	26
10.1. Documents Available from IDT.....	26
10.2. Third-Party Documents.....	26
11 Glossary.....	26
12 Document Revision History.....	27

List of Figures

Figure 3.1 Power Supply Schemes.....	11
Figure 3.2 External Circuitry for /RESET and BSEL.....	12
Figure 3.3 JTAG / SWD Connection for Programming and Debugging.....	13
Figure 4.1 ZWIR4512ACx Pinout.....	14
Figure 5.1 ZWIR4512AC1 Package Drawing (top, side, and bottom view).....	21
Figure 5.2 ZWIR4512AC1 Recommended PCB Footprint (in millimeters).....	21
Figure 5.3 ZWIR4512AC2 Package Drawing (top, side and bottom view).....	22
Figure 5.4 ZWIR4512AC2 Recommended PCB Footprint (in millimeters).....	22
Figure 6.1 Recommended Temperature Profile for Reflow Soldering (according to J-STD-020D).....	23
Figure 8.1 FCC Compliance Statement to be Printed on Equipment Incorporating ZWIR4512 Devices.....	25

List of Tables

Table 2.1 Power Modes Overview.....	10
Table 3.1 External Power Supply Components.....	11
Table 4.1 ZWIR4512ACx Pin Description.....	15
Table 4.2 ZWIR4512ACx GPIO Remapping.....	18
Table 4.3 ZWIR4512ACx GPIO Function Overview.....	19
Table 5.1 ZWIR4512AC1 Physical Dimensions and Tolerances.....	21
Table 5.2 ZWIR4512AC2 Physical Dimensions and Tolerances.....	22
Table 6.1 Soldering Profile Parameters (according to J-STD-020D).....	23

1 Module Characteristics

1.1. Absolute Maximum Ratings

The absolute maximum ratings are stress ratings only. The device might not function or be operable above the operating conditions. Stresses exceeding the absolute maximum ratings might also damage the device. In addition, extended exposure to stresses above the operating conditions might affect device reliability. IDT does not recommend designing to the “Absolute Maximum Ratings.”

1.1.1. Voltage Characteristics

Parameter	Symbol	Min	Max	Unit
Main supply voltage	V_{CC}	-0.3	4	V
Backup supply voltage	V_{BAT}	-0.3	4	
Input voltage at 5V-tolerant GPIO pin	V_{GPIO}	-0.3	5.5	
Input voltage at any other GPIO pin		-0.3	$V_{CC}+0.3$	

1.1.2. Current Characteristics

Parameter	Symbol	Max	Unit
Maximum total current consumption	I_{VCC}	175	mA
Driving strength of each GPIOx pin	I_{GPIO}	± 25	
Driving strength of RF-control pins (PACTLN, PACTLP, DIG1)	I_{RFCTRL}	8	

1.1.3. Thermal Characteristics

Parameter	Symbol	Value	Unit
Storage temperature range	T_{STOR}	-40 to +125	°C
Ambient temperature range	T_{AMB}	-40 to +85	

1.2. Operating Conditions

1.2.1. General Operating Conditions

Note: See important notes at the end of the table.

Parameter	Symbol	Min	Typ	Max	Unit
Electrical Characteristics					
Main supply voltage – ADC not used	V_{CC}	2.0		3.6	V
Main supply voltage – ADC used	V_{CC}	2.4		3.6	
Backup supply voltage	V_{BKUP}	1.8		3.6	
Digital I/O high level input voltage	V_{IH}	$V_{CC} - 0.4$			
Digital I/O low level input voltage	V_{IL}			0.4	

Parameter	Symbol	Min	Typ	Max	Unit
Digital I/O high level output voltage	V_{OH}	$V_{CC} - 0.4$			
Digital I/O low level output voltage	V_{OL}			0.4	
MCU Clock Characteristics					
MCU core clock frequency ¹⁾	f_{AHB}	8		64	MHz
MCU core clock frequency accuracy range	Δf_{AHB}	-2		2.5	%
MCU peripheral bus 1 clock frequency ²⁾	f_{APB1}		4		MHz
MCU peripheral bus 2 clock frequency ²⁾	f_{APB2}		8		
RF Parameters					
Frequency range	f_{RF}	865		928	MHz
Output power ³⁾		-11		10	dBm
Output power tolerance		-3		+3	dB
Receiver sensitivity	BPSK, EU Mode			-110	dBm
	BPSK, US Mode			-108	
	QPSK, EU Mode			-101	
	QPSK, US Mode			-101	
Gross data rate	BPSK, EU Mode			20	kBit/s
	BPSK, US Mode			40	
	QPSK, EU Mode			100	
	QPSK, US Mode			250	
Channel spacing	EU Mode			1	MHz
	US Mode			2	
Number of channels	EU Mode ⁴⁾			1 (+3)	
	US Mode			10	
Input/output impedance			50		Ω
Frequency offset		-10		+10	kHz
1) The f_{CORE} clock can be configured to be 8, 16, 32, or 64 MHz. After reset, the clock is set to 8 MHz. 2) f_{APB1} and f_{APB2} are derived from f_{AHB} . Therefore, the same tolerances apply to these clocks. 3) 10 dBm output power is only available in US Mode; EU Mode provides 5 dBm maximum output power. 4) The IEEE802.15.4 standard defines only 1 channel for EU Mode, but extension channels are available in almost all EU countries.					

1.2.2. Current Consumption per Operating Mode

Operating Mode	Condition	Typ ¹⁾	Unit
Run Mode	Receiver active	10.5	mA
	Transmitter active, EU frequency band, BPSK, 0dBm	16.1	
	Transmitter active, EU frequency band, QPSK, 0dBm	15.5	
	Transmitter active, EU frequency band, BPSK, 5dBm	23.4	
	Transmitter active, EU frequency band, QPSK, 5dBm	22.8	
	Transmitter active, US frequency band, BPSK, 0dBm	14.9	
	Transmitter active, US frequency band, QPSK, 0dBm	14.2	
	Transmitter active, US frequency band, BPSK, 5dBm	18.0	
	Transmitter active, US frequency band, QPSK, 5dBm	17.3	
	Transmitter active, US frequency band, BPSK, 10dBm	24.0	
	Transmitter active, US frequency band, QPSK, 10dBm	23.4	
	TRX Off	0.7	
Stop Mode	TRX Off, RTC running	26.5	μA
Standby Mode	TRX Off, RTC running	3.5	
1) Current consumption values refer to devices operating at 25°C with network stack library version 1.9 and an application that does not generate a workload on the MCU.			

2 Module Description

The ZWIR4512 is a programmable wireless IPv6 communication module. Communication is based on 6LoWPAN, a free and open communication standard developed by the Internet Engineering Task Force (IETF). This standard specifies how to transmit IPv6 (Internet Protocol Version 6) packets over low-power wireless personal area networks.

ZWIR4512 modules are available with a preprogrammed command interface, allowing modem-like communication based on simple commands sent over a serial interface. Alternatively, the module is freely programmable on the basis of an application programming interface (API) that exposes abstract communication functionality to the programmer.

Both software options offer secure communication on the basis of the IP Security (IPSec) protocol suite. Additionally, an implementation of the Internet Key Exchange Protocol version 2 (IKEv2) is provided, in order to make key management as easy as possible. IPSec and IKEv2 are the mandated standards for securing IPv6 networks. Refer to *ZWIR45xx Application Note—Using IPSec and IKEv2 in 6LoWPANs* for more detailed information about IPSec and IKEv2.

The module comprises an STM32F103RC ARM[®] Cortex™-M3 microcontroller from ST Microelectronics and a ZWIR4502 transceiver from IDT. These components ensure leading-edge performance values at very low power consumption. The module provides a hardware-programmed 64-bit MAC address that is guaranteed to be globally unique.

2.1. Radio Transceiver

The module includes IDT's ZWIR4502 radio transceiver. This circuit performs modulation and demodulation of outgoing and incoming data, respectively. The modulation scheme is configurable according to the IEEE802.15.4 standard. The radio transceiver is never accessed directly by application code. This task is performed by the communication stack, which encapsulates such low-level functionality in abstract functions.

2.2. Microcontroller

The protocol stack and the user application are executed on an STM32F103RC microcontroller (MCU) from ST Microelectronics. It provides 256 kB flash and 48 kB SRAM memory. The MCU provides a rich set of peripherals and a number of general purpose input/output (GPIO) ports. The GPIO ports of the module are directly connected to the GPIOs of the MCU. Refer to Table 4.1 for an exact mapping.

2.2.1. MCU Core

The MCU core is an ARM[®] Cortex™-M3. This is a 32-bit RISC core with a performance of 1.25 DMIPS/MHz. Using IDT's software stack, the maximum operating frequency is 64 MHz. This allows for computational intensive applications. In order to save power, the core can be shut off completely, waking up only on external activity.

2.2.2. Peripherals and Interfaces

The module was designed to make maximum use of the controller's internal peripherals. Up to 21 digital general purpose I/Os can be used by the application. Most of these I/Os have alternative functions. Some of them are 5V-tolerant. Table 4.1 shows the most commonly used functions available for each interface. Table 4.3 shows all functionalities on a single page, indicating which peripherals must not be used in parallel as their GPIOs are interfering.

In addition to communication interfaces, the module also provides signal conversion peripherals. Three analog-to-digital converters (ADCs), two digital-to-analog converters (DACs) and two pulse-width modulation (PWM) peripherals are available.

2.2.3. Programming and Debugging

Programming and debugging the module is typically done via JTAG. All required MCU ports are connected to module pins for that purpose. Alternatively, Serial Wire Debug (SWD) can be used for programming and debugging. This requires just two pins that have to be reserved, providing two additional GPIO pins.

Alternatively, if debug functionality is not required, it is possible to program the module over a two-wire UART interface. For that purpose, the MCU's internal boot-loader must be started. This is done by holding the BSEL pin of the module high while a reset is performed or the module is powered on. Refer to the MCU documentation for more information about serial programming.

2.3. Firmware

2.3.1. Serial Command Interface (SCI) Firmware

A module programmed with the Serial Command Interface firmware acts as a network processor. In this configuration, the module is controlled over a serial interface that is SPI, USB, or one of the two UARTs. The SCI firmware provides all standard communication functions for data transmission and reception, as well as all security functions and over-the-air update (OTAU) functionality. Access to internal peripherals is limited to digital control of the GPIO pins. Typically, an external microcontroller or a PC is required to control module operation. However, for simple sensing or acting applications, it is also possible to configure the module to run autonomously without the need for an external controller. Refer to the *ZWIR45xx Serial Command Interface Manual* for further information.

2.3.2. C Application Programming Interface (C-API)

A C-API is provided for applications that should run directly on the embedded microcontroller. Communication and security functionalities are encapsulated in a set of libraries that export functions for accessing and controlling them. The library architecture is modular, allowing tailoring applications to user needs. Applications running on the microcontroller can make use of the rich set of peripherals that are provided by the controller.

Depending on the library configuration, there are up to 192 kB of flash and 32 kB of RAM available for the user application. This is sufficient even for complex applications with high memory needs. If over-the-air update (OTAU) functionality is required, the amount of flash available for user applications is reduced to one half. For further information on C-API programming and OTAU, please refer to the *ZWIR451x Programming Guide* and the *ZWIR45xx Over-the-Air Update Manual*.

2.4. Power Modes

The ZWIR4512 module provides a set of operating modes with different capabilities and power requirements. This document only highlights the main features of these operating modes. Table 2.1 gives an overview of the characteristics of the available power modes. See section 1.2.2 for a table of typical current consumption in the different modes.

Refer to the *ZWIR451x Programming Guide* for detailed usage instructions for the low-power modes.

Table 2.1 Power Modes Overview

Mode	Wakeup		Clock		Context ¹⁾	I/O	Transceiver
	Source	Time	MCU Core	Peripherals			
Run			On	On ²⁾	Retained	As configured	On ³⁾
Sleep	Any IRQ	1.8 μ s	Off	Off ⁴⁾	Retained	As configured	Off ⁴⁾
Stop	RTC IRQ External IRQ	5.4 μ s	Off	Off	Retained	As configured	Off ⁴⁾
Standby	RTC IRQ Wakeup pin	50 μ s	Off	Off	Lost	Analog input	Off

1) Refers to the status of the RAM and peripheral register contents after wakeup – the backup registers of the MCU are always available.
 2) Clock is enabled for all peripherals that have been enabled by application code and all peripherals that are used by the library.
 3) Can be powered off by application code.
 4) Remains if peripheral/transceiver is selected as wakeup source.

2.4.1. Run Mode

In Run Mode, all functions of the module are available. The microcontroller and all its peripherals are powered. Typically the transceiver is also powered, but it can be disabled by software. The module enters Run Mode automatically after startup. The application software must switch to one of the other operating modes if required.

2.4.2. Sleep Mode

In Sleep Mode, the microcontroller core is not clocked. The power state of the transceiver and the microcontroller peripherals depends on the wakeup configuration. All peripherals that are selected as a wakeup source continue to operate. After wakeup, the application program continues execution at the position it was stopped. Sleep Mode allows reacting to external events such as the reception of data, external interrupts, or timer events. The power consumption in this mode strongly depends on which peripherals are enabled. The I/O configuration is not changed during Sleep Mode.

2.4.3. Stop Mode

Stop Mode is an ultra-low-power mode with RAM retention. The MCU core and the MCU peripherals are not clocked. Only the internal real-time clock or any external pin can be used for triggering wakeup from Stop Mode. After wakeup, the program continues execution at the position it was stopped. In Stop Mode, all I/Os remain in the configuration that was active when entering Stop Mode.

2.4.4. Standby Mode

Standby Mode is the lowest power mode. The transceiver and all microcontroller peripherals are consequently powered off. RAM contents are lost. Waking up from Standby Mode can be triggered by a real-time-timer event or by one dedicated pin. When going to Standby Mode, all I/Os are put into analog input mode, so the application circuit must ensure that external components receive defined signal levels if required. When the module exits Standby Mode, it is restarted from the reset handler in the same sequence as the restart after power-on or after the reset button has been pressed.

3 Application Circuits

ZWIR4512 modules are designed to require minimal external circuitry. The following sections illustrate how modules must be connected in order to ensure proper power supply, reset behavior, programmability, and radio performance. Instructions for the connection of GPIO pins are not given.

3.1. Power Supply

All internal components of the ZWIR4512 that require a stable power supply are internally decoupled with a number of capacitors. Nevertheless, the module requires one external decoupling capacitor between VCC and GND. This is the minimal external circuitry required for proper operation.

The module provides two different power supply pins: VCC and VSTDBY. V_{CC} is the normal supply voltage that must be applied in Run, Sleep, or Stop Mode. During Standby Mode, the module is powered by V_{STDBY} and V_{CC} can be switched off.

Figure 3.1 shows two possible power supply schemes. Scheme a) connects VSTDBY to the same voltage source as VCC. This is the commonly used configuration. However, scheme b) allows switching off V_{CC} in Standby Mode. This can help reduce power dissipation in applications with ultra-low power requirements. During the complete standby phase, VSTDBY is powered from a buffering capacitor.

Figure 3.1 Power Supply Schemes

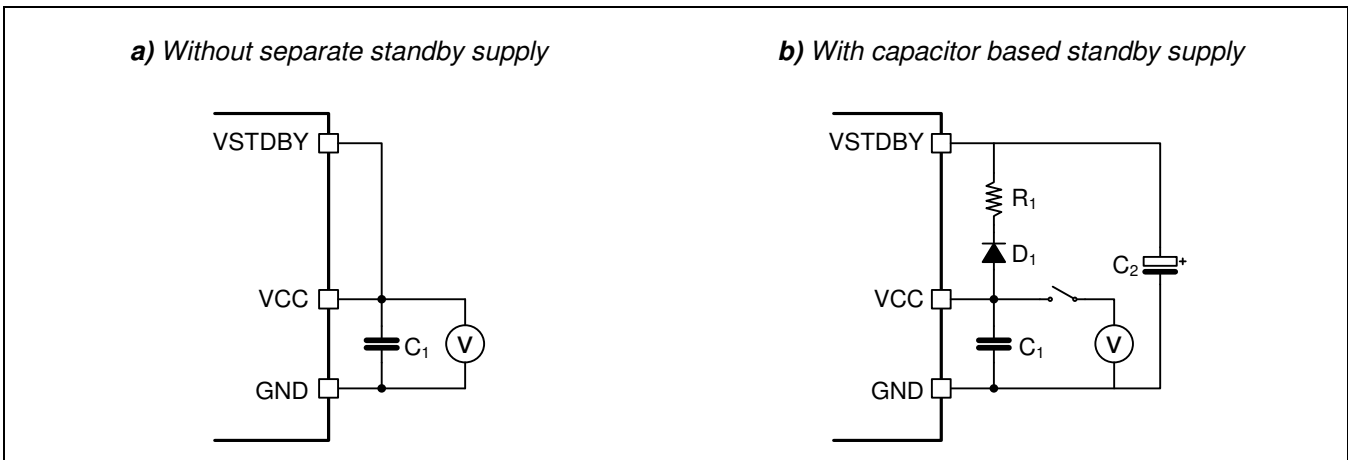

Table 3.1 External Power Supply Components

Symbol	Function	Value/Comment
C ₁	Decoupling capacitor	Mandatory, 10 μ F
R ₁	Charge current limitation	6.8 k Ω
D ₁	Buffering capacitor discharge protection	Schottky diode; e.g., BAT54-02V
C ₂	Buffering capacitor	$\geq 0.1 \mu$ F

3.2. Reset and Boot Select

The /RESET pin is de-bounced and has a pull-up resistor on the PCB. Thus, a push-button can be connected directly to GND or the pin can be left unconnected if it is not required. The boot select pin (BSEL) is pulled down internally. If BSEL is not required, it can be left unconnected. Figure 3.2 shows how these pins are connected externally and illustrates the internal circuitry.

Figure 3.2 External Circuitry for /RESET and BSEL

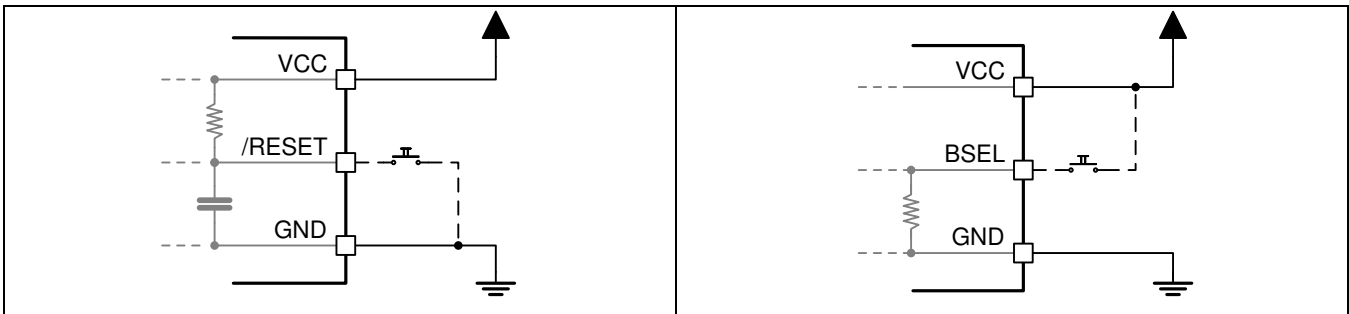

3.3. Debug Access

The ZWIR4512 provides debug access by means of a JTAG or SWD interface. Figure 3.3 shows an example of connecting the module with a 20-pin standard ARM[®] JTAG header. If no JTAG connection is required, the dotted connections can be left out and two additional pins are available as GPIOs.

Figure 3.3 JTAG / SWD Connection for Programming and Debugging

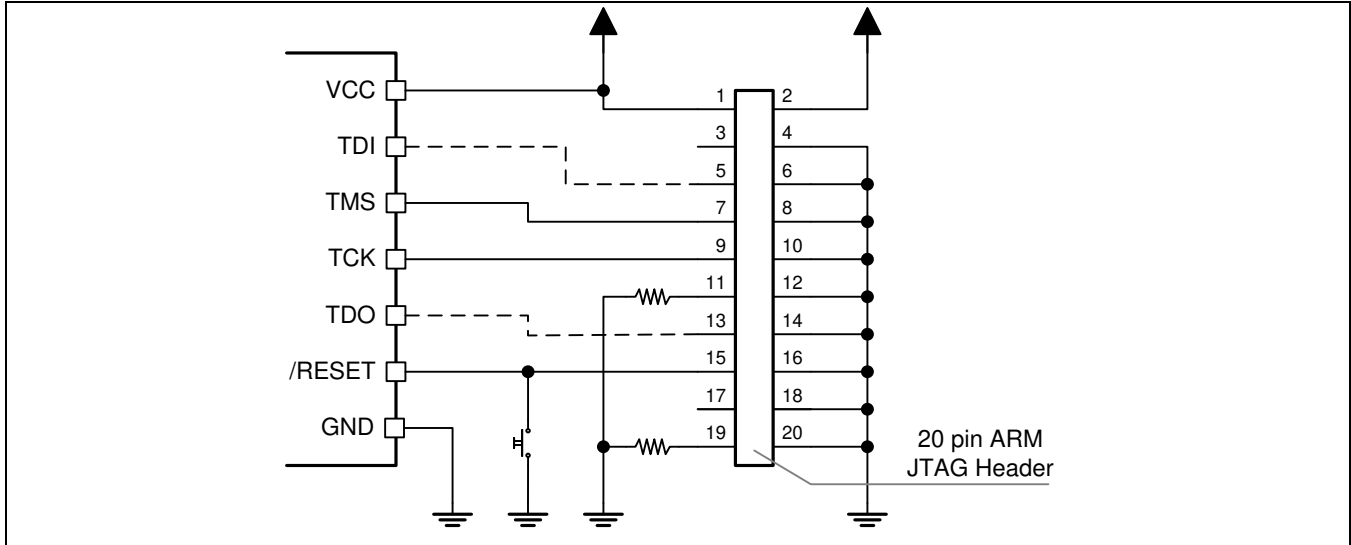

3.4. Antenna

There are two options to connect an external antenna. The antenna can be connected to the module using a coaxial cable that is mounted on the U.FL connector, or an external antenna terminal on the host PCB can be connected to the ANT pin. If the on-board U.FL connector is used, the ANT pin must be left unconnected. An external antenna must be connected with a 50 Ω microstrip wire.

4 Pinout

Each of the ZWIR4512 GPIO pins may have different functionalities, controllable by software. The most commonly used functions available on each pin are listed in Table 4.1. Furthermore, the GPIO peripheral functions are shown as an overview in Table 4.3. The full list of available functions of each pin can be obtained from the STM32F103xC data sheet.

Some peripheral I/O functions are available through different pins. The default GPIO pin for each peripheral function is marked with a ♦ in Table 4.3. When it is possible to remap a peripheral function to another module pin, this is marked with a letter. The corresponding remapping function is described in Table 4.2.

Figure 4.1 ZWIR4512ACx Pinout

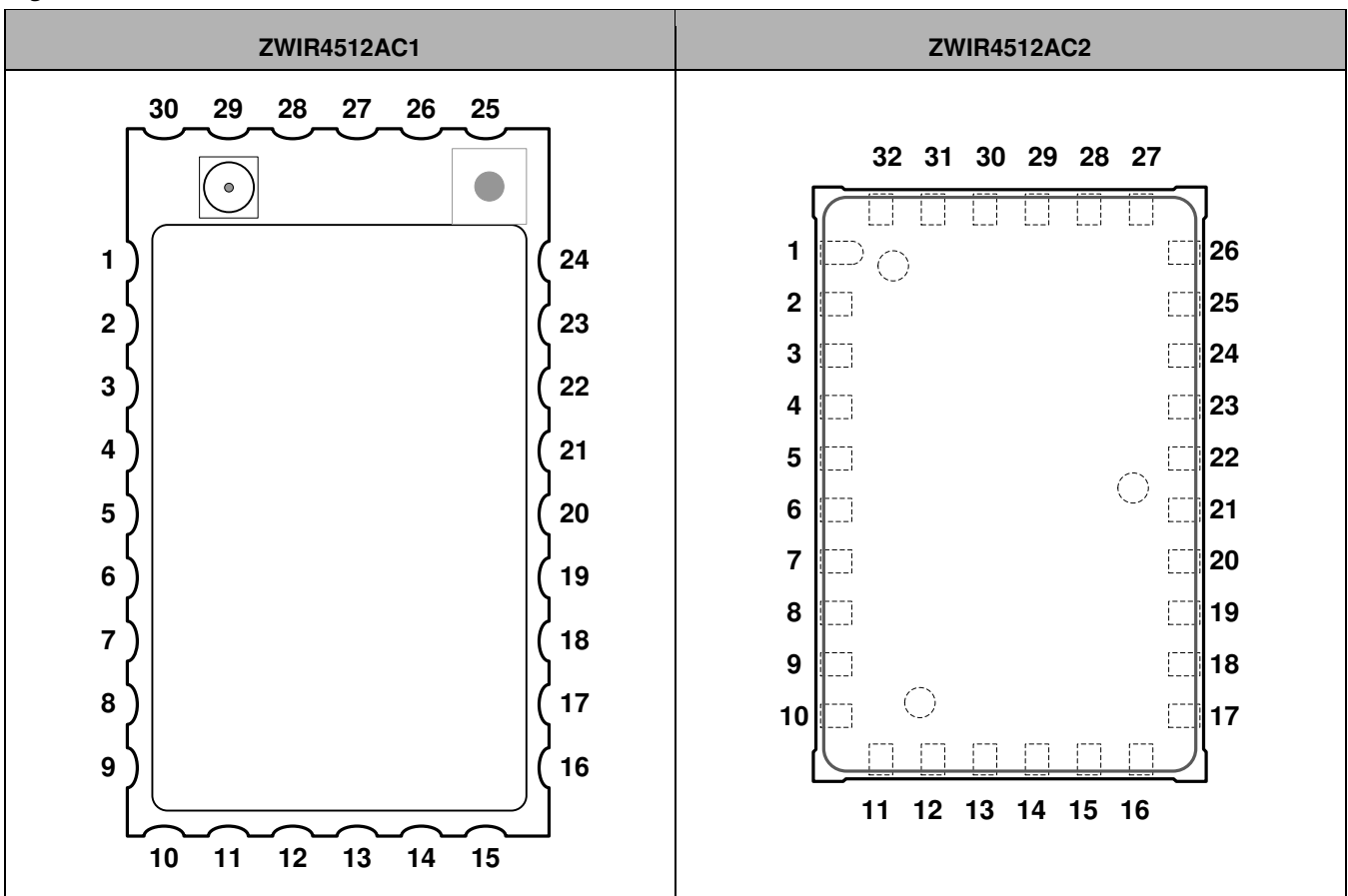

Table 4.1 ZWIR4512ACx Pin Description

Pins		Name	MCU Port	Type ¹⁾	5V	API Function ^{2), 3)}	SCI Function ^{3), 4)}
ZWIR4512AC1	ZWIR4512AC2						
1	1	GPIO7	PA7	IO		GPIO SPI1 – MOSI ADC1 / ADC2 – channel 7 PWM	SPI – MOSI
2	2	GPIO6	PA6	IO		GPIO SPI1 – MISO ADC1 / ADC2 – channel 6 PWM	SPI – MISO
3	3	GPIO5	PA5	IO		GPIO SPI1 – SCK DAC – OUT2 ADC1 / ADC2 – channel 5	SPI – SCK
4	4	GPIO4	PA4	IO		GPIO SPI1 – NSS USART2 – CK DAC – OUT1 ADC1 / ADC2 – channel 4	SPI – NSS GPIO
5	5	GPIO3	PA3	IO		GPIO USART2 – RX ADC1 / ADC2 / ADC3 – channel 3 PWM	UART2 – RX GPIO
6	6	GPIO2	PA2	IO		GPIO USART2 – TX ADC1 / ADC2 / ADC3 – channel 2 PWM	UART2 – TX
7	7	GPIO1	PA1	IO		GPIO USART2 – RTS ADC1 / ADC2 / ADC3 – channel 1 PWM	GPIO UART2 - RTS

Pins		Name	MCU Port	Type ¹⁾	5V	API Function ^{2), 3)}	SCI Function ^{3), 4)}
ZWIR4512AC1	ZWIR4512AC2						
8	8	GPIO0	PA0-WKUP	IO		GPIO WKUP USART2 – CTS ADC1 / ADC2 / ADC3 – channel 0 PWM	GPIO UART2 CTS
9	9	GPIO12	PC13	IO		GPIO TAMPER-RTC	GPIO
18	10	VSTDBY	VBAT	S		Alternative Standby Mode power supply	
10	11	/RESET	NRST	I	✓	Reset	
11	12	GND	GND	S		Ground	
12	13	GPIO9	PA10	IO	✓	GPIO USART1 – RX PWM	UART1 – RX GPIO
13	14	GPIO8	PA9	IO	✓	GPIO USART1 – TX PWM	UART1 – TX GPIO
14	15	VCC	VCC	S		Power supply	
15	16	BSEL	BOOT0	I		Boot mode selection	
n/a	17	GPIO15	PC14	IO		GPIO OSC32 – IN	GPIO
n/a	18	GPIO16	PC15	IO		GPIO OSC32 – OUT	GPIO
16	19	GPIO10	PA11	IO	✓	GPIO USART1 – CTS USB – D- CAN – RX PWM	GPIO UART1 – CTS
17	20	GPIO11	PA12	IO	✓	GPIO USART1 – RTS USB – D+ CAN – TX Timer Trigger (TIM1)	GPIO UART1 – RTS

Pins		Name	MCU Port	Type ¹⁾	5V	API Function ^{2), 3)}	SCI Function ^{3), 4)}
ZWIR4512AC1	ZWIR4512AC2						
19	21	TDO	PB3	IO	✓	<i>JTAG – TDO</i> GPIO PWM	
20	22	TMS	PA13	IO	✓	<i>JTAG – TMS, SWDIO</i> GPIO	GPIO
21	23	TDI	PA15	IO	✓	<i>JTAG – TDI</i> GPIO	GPIO
22	24	TCK	PA14	IO	✓	<i>JTAG – TCK, SWCLK</i> GPIO	GPIO
23	25	GPIO14	PB7	IO	✓	GPIO <i>I²C™ – SDA</i> UART1 – RX PWM	GPIO
24	26	GPIO13	PB6	IO	✓	GPIO <i>I²C™-SCL</i> UART1 – TX PWM	GPIO
25	27	DIG1	-	O		Unused, leave unconnected	
26	28	PACTLN	-	O		PA control (differential) complementary output, leave unconnected if unused	
27	29	PACTLP	-	O		PA control (differential), leave unconnected if unused	
28	30	GND	GND	S		Ground	
29	31	ANT	-	IO		Antenna pin	
30	32	GND	GND	S		Ground	

1) The "Type" column indicates the type of the pin: IO = input/output, I = input only, O = output only, S = power supply.

2) The listed functionalities include only the most important functionalities – please refer to the STM32F103xC data sheet for a full list.

3) Functions listed in italic letters are selected by default if the device is not reprogrammed. GPIOs are analog inputs by default.

4) Any pin marked as GPIO can be configured as indicator for incoming or outgoing packets on network or serial interfaces.

Table 4.2 ZWIR4512ACx GPIO Remapping

Name	Peripheral	Pin	Change	Required Action
A	UART1	RX	PA10 → PB7	Write 1 _{BIN} to AFIO_MAPR[2] (See sections 8.3 and 8.4.2 of the <i>STM32F103xx Reference Manual.</i>)
		TX	PA9 → PB6	
		RTS	PA12 → ∅	
		CTS	PA11 → ∅	
B	Timer 1	CH1N	∅ → PA7	Write 01 _{BIN} to AFIO_MAPR[11:10]
C	Timer 2	Ch2	PA1 → PB3	Write 01 _{BIN} to AFIO_MAPR[9:8]
		Ch1	PA0 → PA15	
D	JTAG	TDI	PA15 → ∅	Write 010 _{BIN} to AFIO_MAPR[26:24]
		TDO	PB3 → ∅	
E	JTAG	TMS	PA13 → ∅	Write 100 _{BIN} to AFIO_MAPR[26:24]
		TCK	PA14 → ∅	
		TDI	PA15 → ∅	
		TDO	PB3 → ∅	

Table 4.3 ZWIR4512ACx GPIO Function Overview

Note: See important notes at end of table.

ZWIR4512AC2-Pin		1	2	3	4	5	6	7	8	9	13	14	17	18	19	20	21	22	23	24	25	26		
ZWIR4512AC1-Pin		1	2	3	4	5	6	7	8	9	12	13	-	-	16	17	19	20	21	22	23	24		
MCU - GPIO Port		A7	A6	A5	A4	A3	A2	A1	A0	C13	A10	A9	C14	C15	A11	A12	B3 ¹⁾	A13 ²⁾	A15 ¹⁾	A14 ²⁾	B7	B6		
UART1	RX										◆											A		
	TX											◆											A	
	RTS															◆,A								
	CTS															◆,A								
USART2	RX					◆																		
	TX						◆																	
	RTS							◆																
	CTS								◆															
	CK				◆																			
SPI1	MOSI	◆																						
	MISO		◆																					
	SCK			◆																				
	NSS				◆																			
I ² C™	SDA																					◆		
	SCL																						◆	
USB	D-															◆								
	D+																◆							
CAN	RX															◆								
	TX																◆							
Standby Wakeup									◆															
PWM	T1 - Ch1N	B																						
	T1 - Ch2											◆,B												
	T1 - Ch3										◆,B													
	T1 - Ch4															◆,B								
	T2 - Ch1								◆											C ¹⁾				
	T2 - Ch2							◆									C ¹⁾							
	T2 - Ch3						◆,C																	
	T2 - Ch4					◆,C																		
	T3 - Ch1		◆																					
	T3 - Ch2	◆																						
	T4 - Ch1																						◆	
	T4 - Ch2																					◆		
	T5 - Ch1									◆														
	T5 - Ch2								◆															
T5 - Ch3							◆																	
T5 - Ch4					◆																			
ADC	Ch0										◆													
	Ch1											◆												
	Ch2							◆																
	Ch3					◆																		
	Ch4				◆																			
	Ch5			◆																				
	Ch6		◆																					
Ch7	◆																							
DAC	DAC1				◆																			
	DAC2			◆																				

ZWIR4512AC2-Pin	1	2	3	4	5	6	7	8	9	13	14	17	18	19	20	21	22	23	24	25	26	
ZWIR4512AC1-Pin	1	2	3	4	5	6	7	8	9	12	13	-	-	16	17	19	20	21	22	23	24	
MCU - GPIO Port	A7	A6	A5	A4	A3	A2	A1	A0	C13	A10	A9	C14	C15	A11	A12	B3 ¹⁾	A13 ²⁾	A15 ¹⁾	A14 ²⁾	B7	B6	
JTAG	TMS																◆ ³⁾					
	TCK																		◆ ³⁾			
	TDI																	◆ ³⁾				
	TDO															◆ ³⁾						
SWD	SWDIO																◆,D ⁴⁾					
	SWDCLK																		◆,D ⁴⁾			

1) GPIO or peripheral functionality of this port is only available with remap function D or E active.
 2) GPIO functionality of this port is only available with remap function E active.
 3) JTAG functionality is only available when remap functions D and E are inactive.
 4) SWD functionality is only available when remap function E is inactive.

5 Package Dimensions and PCB Footprints

5.1. ZWIR4512AC1

Figure 5.1 ZWIR4512AC1 Package Drawing (top, side, and bottom view)

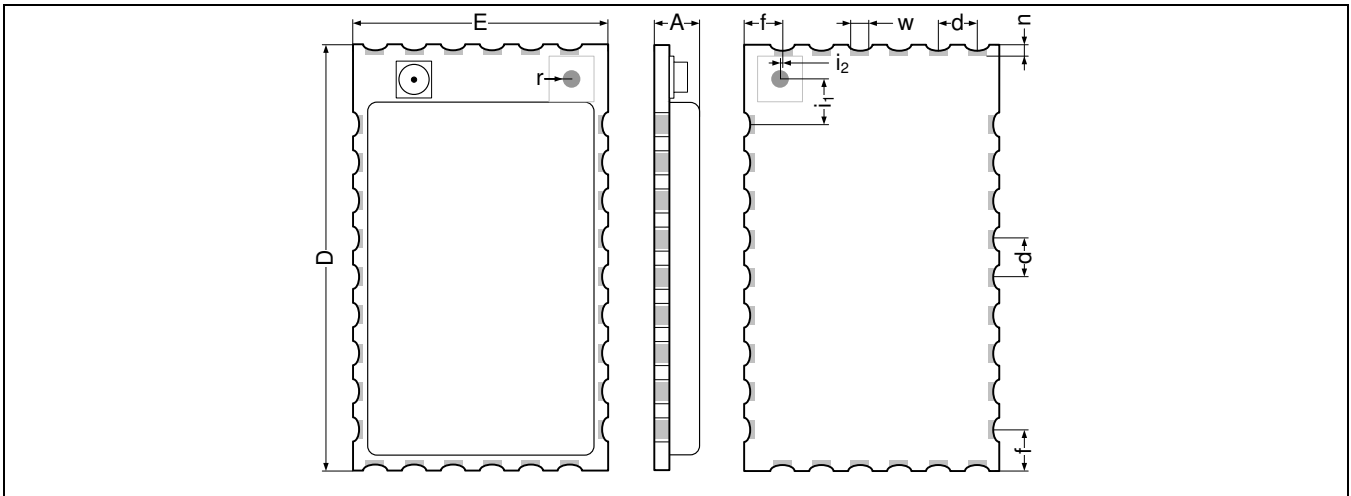
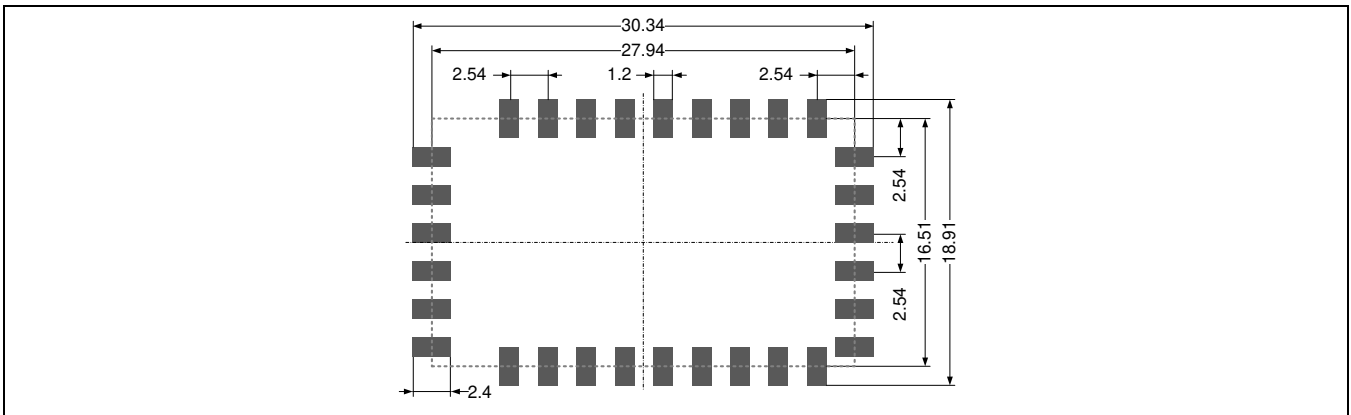

Table 5.1 ZWIR4512AC1 Physical Dimensions and Tolerances

Symbol	Millimeters			Symbol	Millimeters		
	Min	Typ	Max		Min	Typ	Max
A	3.7	3.8	3.9	n		1	
D	27.74	27.94	28.14	w	1.08	1.1	1.12
E	16.31	16.51	16.71	i ₁		2.67	
d		2.54		i ₂		0.27	
f	2.44	2.54	2.64	r		0.5	

Figure 5.2 ZWIR4512AC1 Recommended PCB Footprint (in millimeters)



5.2. ZWIR4512AC2

Figure 5.3 ZWIR4512AC2 Package Drawing (top, side and bottom view)

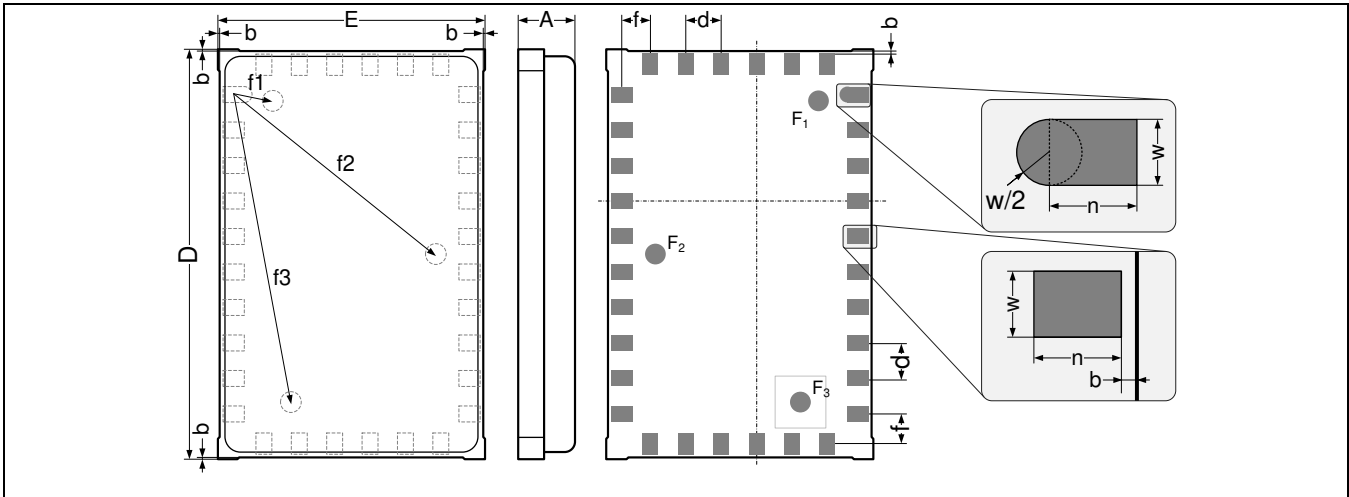
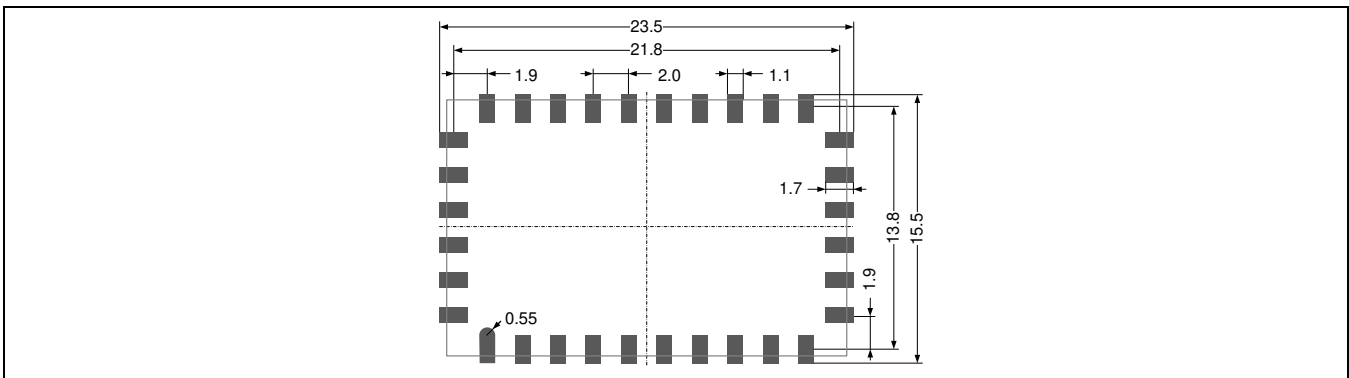

Table 5.2 ZWIR4512AC2 Physical Dimensions and Tolerances

Symbol	Millimeters			Symbol	Millimeters		
	Min	Typ	Max		Min	Typ	Max
A	3.7	3.8	3.9	b	0	0.1	0.2
D	22.9	23.1	23.3	$f1_x^{1)}$		2.0	
E	14.9	15.1	15.3	$f1_y^{1)}$		0.5	
d		2		$f2_x^{1)}$		11.5	
f		1.75		$f2_y^{1)}$		9.0	
n		1.2		$f3_x^{1)}$		3.5	
w		0.9		$f3_y^{1)}$		17.5	

1) Fiducial positions are relative to center point of pad 1 rectangle, top view.

Figure 5.4 ZWIR4512AC2 Recommended PCB Footprint (in millimeters)



6 Soldering Information

To ensure that soldered connections do not break during the reflow soldering process of the application PCB, the soldering profile described in Table 6.1 and Figure 6.1 must be maintained. This profile is aligned with the profile defined in the IPC/JEDEC standard J-STD-020D.

Table 6.1 Soldering Profile Parameters (according to J-STD-020D)

Profile Feature	Symbol	Min	Max	Unit
Time 25°C to T_P	t_H		8	min
Peak package body temperature	T_P		260	°C
Preheat / Soak				
Soak temperature	T_S	100	150	°C
Soak time	t_S	60	120	s
Ramp-up				
Ramp-up rate	T_L to T_P		3	°C/s
Time maintained above T_L	t_L		150	s
Time within 5°C of T_P	t_P		30	s
Ramp-down				
Ramp-down rate	T_P to T_L		6	°C/s

Figure 6.1 Recommended Temperature Profile for Reflow Soldering (according to J-STD-020D)

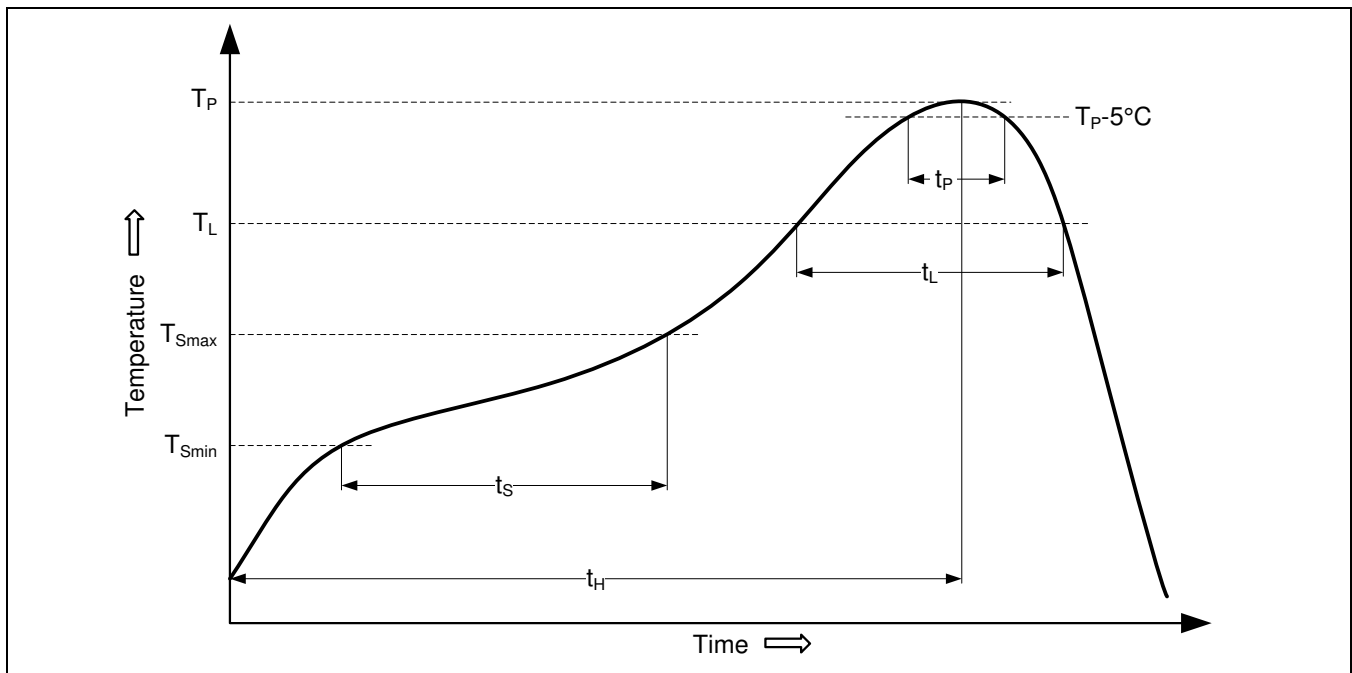

7 Customization

For larger order quantities, it is possible to deliver modules with preprogrammed customer firmware. Depending on the quantity and user requirements, hardware customization to fit customer needs might be possible. Please contact our support team for requests regarding module customization.

8 Certification

8.1. European R&TTE Directive Statements

The ZWIR4512 module has been tested and found to comply with Annex IV of the R&TTE Directive 1999/5/EC and is subject of a notified body opinion. The module has been approved for Antennas with gains of 4 dBi or less.

8.2. Federal Communication Commission Certification Statements

8.2.1. Statements

This equipment has been tested and found to comply with the limits for a **Class B Digital Device**, pursuant to Part 15 of the FCC Rules. These limits are designed to provide reasonable protection against harmful interference in a residential installation. This equipment generates, uses, and can radiate radio frequency energy and, if not installed and used in accordance with the instructions, may cause harmful interference to radio communications. However, there is no guarantee that interference will not occur in a particular installation. If this equipment does cause harmful interference to radio or television reception, which can be determined by turning the equipment off and on, the user is encouraged to try to correct the interference by one or more of the following measures:

- Reorient or relocate the receiving antenna.
- Increase the separation between the equipment and receiver.
- Connect the equipment into an outlet on a circuit different from where the receiver is connected.
- Consult the dealer or an experienced radio/TV technician for help.

This device complies with part 15 of the FCC Rules. Operation is subject to the following two conditions: (1) This device may not cause harmful interference, and (2) this device must accept any interference received, including interference that may cause undesired operation.

Modifications not expressly approved by ZMD AG could void the user's authority to operate the equipment.

The internal/external antennas used for this mobile transmitter must provide a separation distance of at least 20cm from all persons and must not be co-located or operating in conjunction with any other antenna or transmitter.

8.2.2. Requirements

The ZWIR4512 complies with Part 15 of the FCC rules and regulations. In order to retain compliance with the FCC certification requirements, the following conditions must be met:

1. Modules must be installed by original equipment manufacturers (OEM) only.
2. The module must only be operated with antennas adhering to the requirements defined in section 8.3.
3. The OEM must place a clearly visible text label on the outside of the end-product containing the text shown in Figure 8.1, below.

IMPORTANT: The compliance statement as shown in Figure 8.1 must be used without modifications for both ZWIR4512 product versions as the FCC ID covers the ZWIR4512AC1 and the ZWIR4512AC2!

Figure 8.1 *FCC Compliance Statement to be Printed on Equipment Incorporating ZWIR4512 Devices*

Contains FCC ID: COR-ZWIR4512AC1
This device complies with part 15 of the FCC Rules. Operation is subject to the following two conditions: (1) This device may not cause harmful interference, and (2) this device must accept any interference received, including interference that may cause undesired operation.

8.3. Supported Antennas

The FCC compliance testing of the ZWIR4512 has been carried out using the MEXE902RPSM antenna from PCTEL Inc. This antenna has an omnidirectional radiation pattern at an antenna gain of 2 dBi. In order to be allowed to use the module without re-certification, the product incorporating the ZWIR4512 module must either use the antenna mentioned above or must use an antenna with an omnidirectional radiation pattern and a gain being less than or equal to 2 dBi.

9 Ordering Information

Product Sales Code	Description	Package
ZWIR4512AC1xA	Unprogrammed module for user application programs	30 pin SMT, 27.9 mm x 16.5 mm
ZWIR4512AC1xI	Preprogrammed module with serial command interface	30 pin SMT, 27.9 mm x 16.5 mm
ZWIR4512AC2xA	Unprogrammed module for user application programs	32 pin LGA, 23.1 mm x 15.1 mm
ZWIR4512AC2xI	Preprogrammed module with serial command interface	32 pin LGA, 23.1 mm x 15.1 mm
ZWIR4512-Devkit	Development kit	