



Chipsmall Limited consists of a professional team with an average of over 10 year of expertise in the distribution of electronic components. Based in Hongkong, we have already established firm and mutual-benefit business relationships with customers from,Europe,America and south Asia,supplying obsolete and hard-to-find components to meet their specific needs.

With the principle of “Quality Parts,Customers Priority,Honest Operation,and Considerate Service”,our business mainly focus on the distribution of electronic components. Line cards we deal with include Microchip,ALPS,ROHM,Xilinx,Pulse,ON,Everlight and Freescale. Main products comprise IC,Modules,Potentiometer,IC Socket,Relay,Connector.Our parts cover such applications as commercial,industrial, and automotives areas.

We are looking forward to setting up business relationship with you and hope to provide you with the best service and solution. Let us make a better world for our industry!



Contact us

Tel: +86-755-8981 8866 Fax: +86-755-8427 6832

Email & Skype: info@chipsmall.com Web: www.chipsmall.com

Address: A1208, Overseas Decoration Building, #122 Zhenhua RD., Futian, Shenzhen, China



ZXCT1011

High-side low drift current monitor

Description

The ZXCT1011 is a high side current sense monitor. Using this type of device eliminates the need to disrupt the ground plane when sensing a load current.

The ZXCT1011 takes the voltage developed across a current shunt resistor and translates it into a proportional output current.

A user defined output resistor scales the output current into a ground referenced voltage.

A current reference resistor, external to the IC, results in an improved temperature coefficient compared to the ZXCT1009.

The wide input voltage range of 20V down to as low as 2.5V make it suitable for a range of applications. With a minimum operating current of just 4uA, combined with its SOT23-5 package make it suitable for portable battery equipment too.

Features

- Accurate high-side current sensing
- 2.5V to 20V supply range
- 4 μ A quiescent current
- 1% typical accuracy
- Package SOT23-5
- Temperature range -40 to 125°C

Applications

- Automotive current measurement
- Battery management
- DC motor and solenoid control
- Over current monitor
- Power management

Typical application circuit

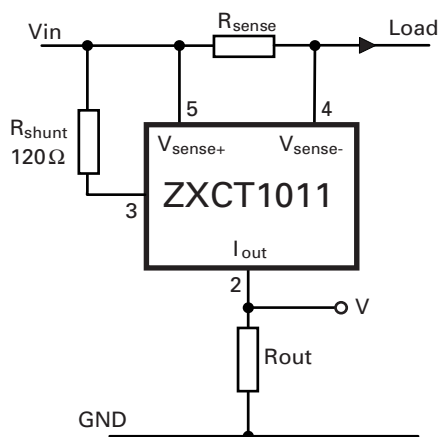

Pin connections

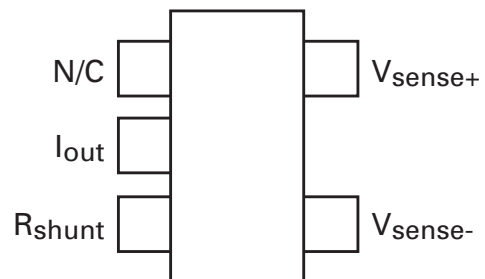

Ordering information

Order code	Pack	Part mark	Reel Size inches (mm)	Tape width	Quantity Per reel
ZXCT1011E5TA	SOT23-5	1011	7 (180)	8mm	3,000

Absolute maximum ratings

$V_{\text{sense+}}$	20 V
Voltage on any pin	0.6V and $V_{\text{sense+}} + 0.5V$
$V_{\text{sense+}}$ to $V_{\text{sense-}}$	2.5V
Operating temperature	-40 to 125°C
Storage temperature	-55 to 150°C
Maximum junction temperature	150°C
Package power dissipation	300mW at $T_A = 25^\circ\text{C}$ (De-rate to zero at 150°C)

Operation above the absolute maximum rating may cause device failure. Operation at the absolute maximum ratings, for extended periods, may reduce device reliability.

Electrical characteristics

Test conditions $T_A = 25^\circ\text{C}$, $V_{\text{in}} = 5V$, $R_{\text{shunt}} = 120\Omega$, $V_{\text{sense}} = 100\text{mV}$. Unless otherwise stated.

Symbol	Parameter	Conditions	Min	Typ.	Max	Units
V_{in}^*	Supply range	-	2.5	-	20	V
I_{out}	Output current	$V_{\text{sense}} = 0V$ $= 10\text{mV}$ $= 30\text{mV}$ $= 100\text{mV}$ $= 200\text{mV}$ $= 500\text{mV}$	1 84 273 0.97 1.95 4.85	4 116 320 1.00 2.00 5.00	15 124 330 1.03 2.05 5.15	μA μA μA mA mA mA
V_{sense}	Sense voltage [†]	-	0	-	500	mV
$I_{\text{sense-}}$	$V_{\text{sense-}}$ input current	-	-	-	100	nA
Acc	Accuracy	$R_{\text{sense}} = 0.1\Omega$ $V_{\text{sense}} = 100\text{mV}$	-3	-	3	%
g_m	Transconductance $I_{\text{out}}/V_{\text{sense}}$	$R_{\text{shunt}} = 120\Omega$	-	10	-	mA/V
T_c	Temperature coefficient [‡]	-	-	30	150	ppm/°C
BW^{**}	Bandwidth	$V_{\text{sense}} = 10\text{mV}$ $CL = 5\text{pF}$, $R_{\text{out}} = 1\text{k}\Omega$ $V_{\text{sense}} = 100\text{mV}$ $CL = 5\text{pF}$, $R_{\text{out}} = 1\text{k}\Omega$	-	400 1.5	-	kHz MHz
PSSR	Supply rejection	$V_{\text{sense}} = 200\text{mV}$, $R_{\text{out}} = 1\text{k}\Omega$	-	68	-	dB

NOTES:

* $V_{\text{sense+}}$ relative to I_{out} .

† $V_{\text{sense}} = (V_{\text{sense+}}) - (V_{\text{sense-}})$.

‡ Temperature dependent measurements are extracted from characterization and simulation results.

** Where CL is the capacitance across R_{out} .

Typical characteristics

$T_A=25^\circ\text{C}$, $R_{\text{shunt}} = 120$ unless otherwise stated.

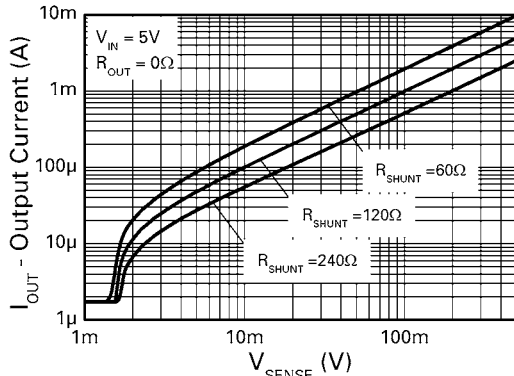

Output v Sense Voltage

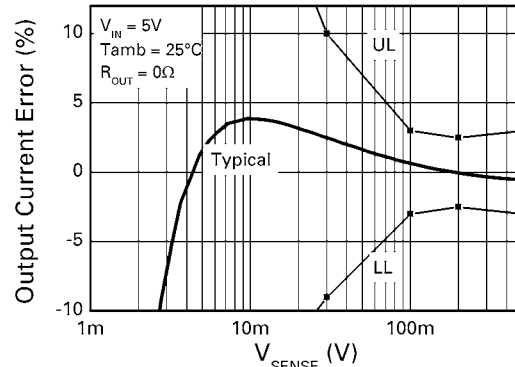

Error v Sense Voltage

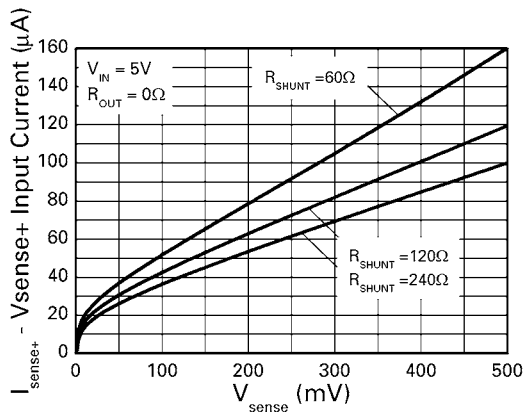

Vsense+ Current v Sense Voltage

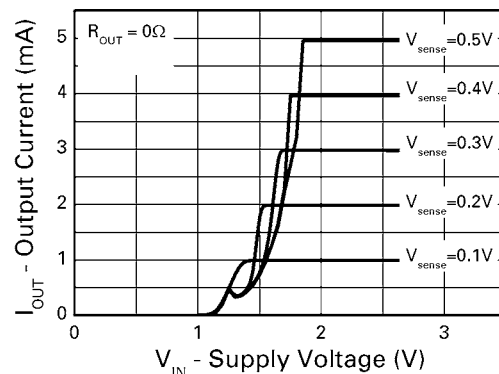

Transfer Characteristic

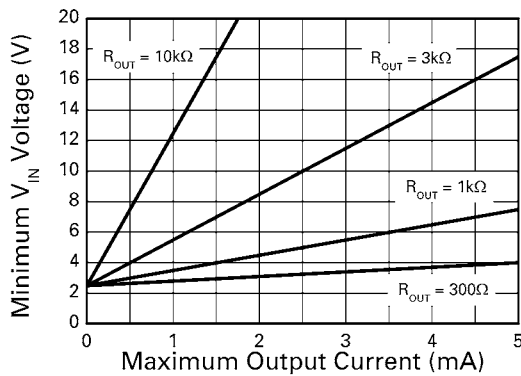

Minimum Useable Supply Voltage

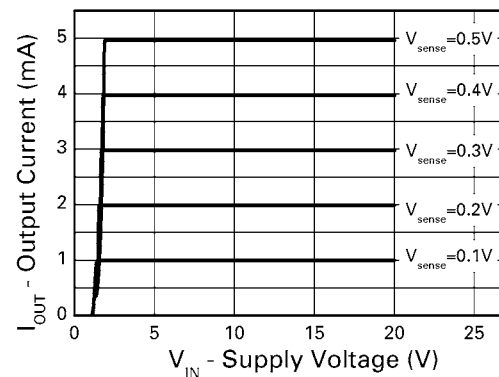

Transfer Characteristic

Typical characteristics

$T_A=25^\circ\text{C}$, $R_{\text{shunt}} = 120$ unless otherwise stated.

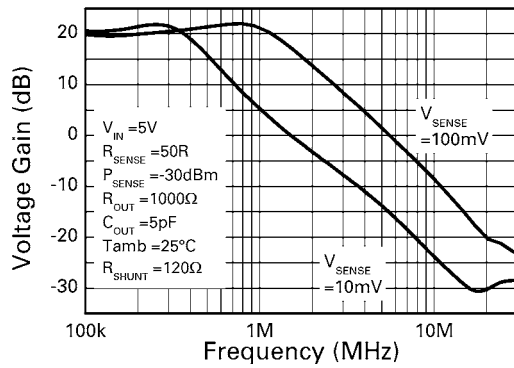

Frequency Response

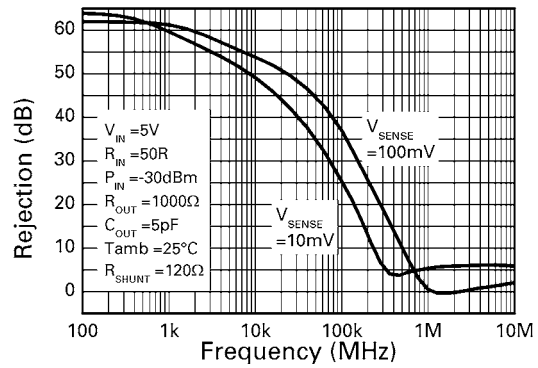

Common Mode Rejection

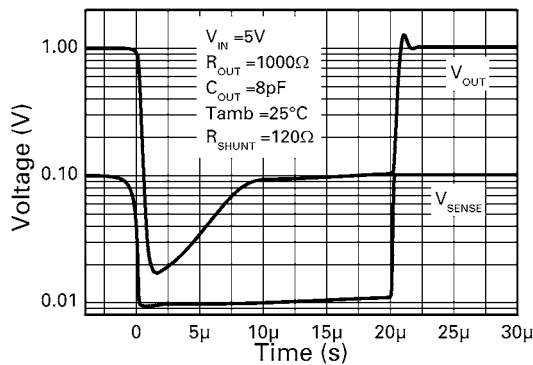

Large Signal Step Response

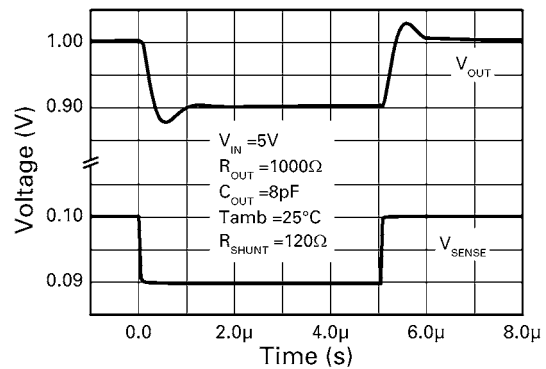

Small Signal Step Response

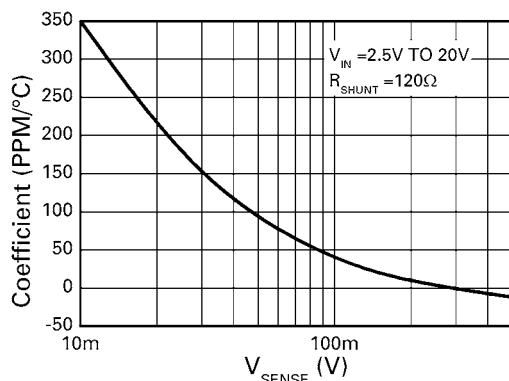

Transconductance v Temperature

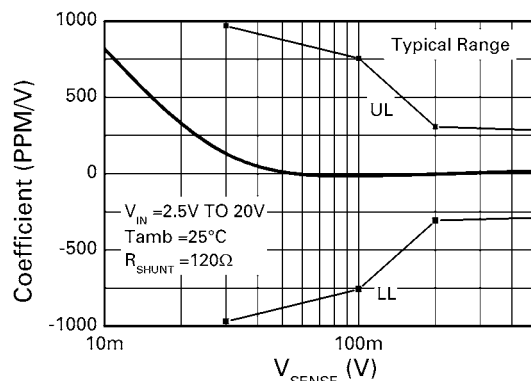

Transconductance v Voltage

Pin description

Pin no.	Pin name	Pin function
1	N/C	No connection
2	I_{out}	Output current - follows transconductance of sense voltage $g_m = 10\text{mA/V}$ for $R_{shunt}=120\Omega$
3	R_{shunt}	Trimming resistor Input. - used to trim gain value $60\Omega \leq R_{shunt} \leq 240\Omega$
4	V_{sense-}	Low side current sense input. – connect to load/battery etc. Must be lower than V_{sense+} for correct operation. Cannot be grounded without additional series resistor.
5	V_{sense+}	High side current sense input. – Connect to supply rail. Must be higher than V_{sense+} for correct operation.

Application information

Design example

The following lines describe how to scale a load current to an output voltage.

$$V_{sense} = (V_{sense+}) - (V_{sense-}) = I_{load} \times R_{sense}$$

Defining then

$$I_{out} = I_q + V_{sense} \times g_m$$

since

$$g_m = 1.2 / R_{shunt}$$

$$I_{out} = I_q + [(V_{sense} \times 1.2) / R_{shunt}]$$

$$= I_q + [(1.2 \times I_{load} \times R_{sense} / R_{shunt})]$$

Note: I_q is embedded into the specification of the ZXCT1011 and therefore appears an offset error.

$$\therefore V_{out} = (R_{out} \times I_{offset}) + [(1.2 \times R_{out} \times I_{load} \times R_{sense}) / R_{shunt}]$$

The output current of the ZXCT1011 is directly related to the size of the trimming resistor used. It is important to ensure the tolerance of R_{shunt} is considered. A 1% change in R_{shunt} will cause a 1% change in output.

Consider the following: -

ZXCT1011

A 1 ampere load current is to be measured into a battery. The output signal required to an over current controller needs to be 3.3V. What is a suitable value of R_{out} and what will the error due to the supply current be?

$$V_{in} = 5.0V - 9.0V$$

$$I_{load} = 1.0A$$

Output signal required: 3.3V

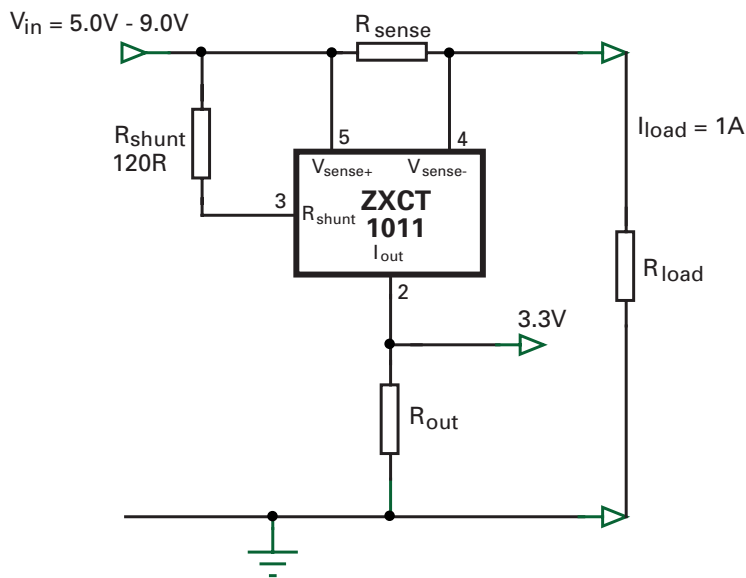

Figure 1 ZXCT1011 to measure a 1.0 A load current

To obtain the highest accuracy, choose the of R_{sense} to give 100mV:

$$R_{sense} = 0.1/1.0 = 0.1\Omega$$

The transconductance using a 120 Ω resistor will be 10mA/V.

Choose R_{out} to give $V_{out} = 3.3V$, when $V_{sense} = 100mV$

Rearranging equation 1 without the offset error gives:

$$R_{out} = (V_{out} \times R_{shunt}) / (1.2 \times I_{Load} \times R_{sense})$$

$$R_{out} = 3.3k\Omega$$

Now consider the offset error for this resistor:

$$\text{Offset due to supply current} = R_{out} \times 4 \times 10^{-6} \mu A = 13.2mV = 0.4\%$$

Application information (cont.)

Minimum operating voltage

The minimum operating voltage of the ZXCT1011 is 2.5V and is defined as the difference between $V_{\text{sense+}}$ and the I_{out} pin. It must be ensured that sufficient headroom is given for the operation of the device when considering R_{out} .

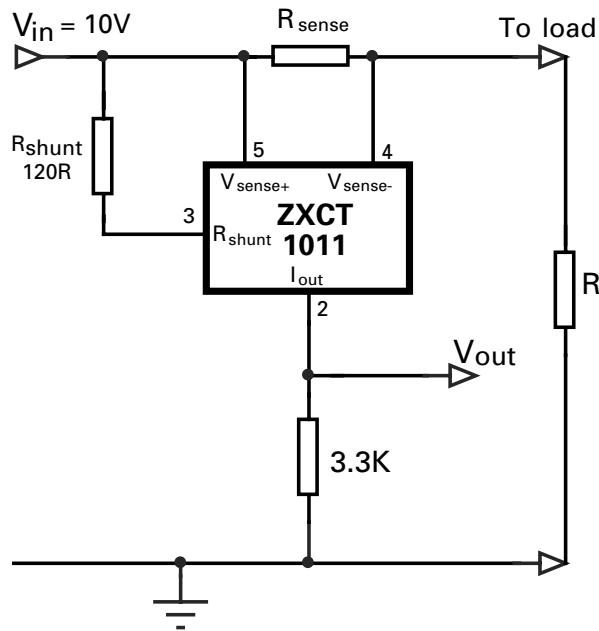

Figure 2 Considerations for supply rail

Voltage across device 2.5V

$V_{\text{in}} - V_{\text{out}} = 2.5\text{V}$

Where $V_{\text{out}} = I_{\text{out}} \times R_{\text{out}}$

At low supply voltages and high Vsense measurements, special care must be taken to ensure the correct operation.

The circuit in figure 2.0 shows a ZXCT1011 operating from 10V supply rail. The minimum operating voltage of the ZXCT1011 is 2.5V. This allows a maximum output voltage of 7.5V to be set at V_{out} . A 3k resistor on the output would draw a maximum 2.5mA from I_{out} . - See minimum usable supply voltage graph on page 4.

Packaging details - SOT23-5

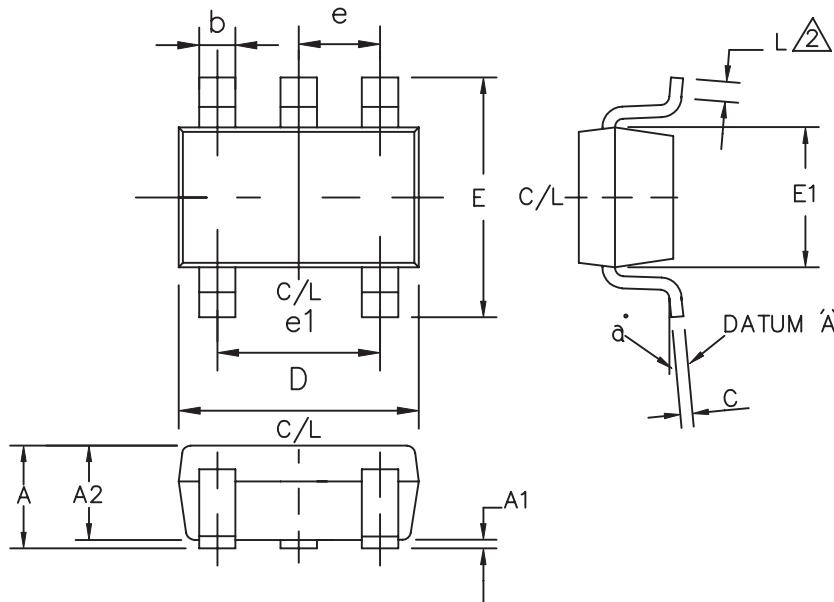

DIM	MILLIMETRES		INCHES	
	MIN	MAX	MIN	MAX
A	0.90	1.45	0.0354	0.0570
A1	0.00	0.15	0.00	0.0059
A2	0.90	1.30	0.0354	0.0511
b	0.20	0.50	0.0078	0.0196
C	0.09	0.26	0.0035	0.0102
D	2.70	3.10	0.1062	0.1220
E	2.20	3.20	0.0866	0.1181
E1	1.30	1.80	0.0511	0.0708
L	0.10	0.60	0.0039	0.0236
e	0.95	REF	0.0374	REF
e1	1.90	REF	0.0748	REF
a	0°	30°	0°	30°

NOTE

- 1 ALL DIMENSIONS ARE IN MILLIMETRES .
- 2 FOOT LENGTH MEASURED REFERENCE TO FLAT FOOT SURFACE PARALLEL TO DATUM 'A' .
- 3 PACKAGE OUTLINE EXCLUSIVE OF MOLD FLASH AND METAL BURR.
- 4 COMPLY TO EIAJ SC74A.

Europe

Zetex GmbH
Streitfeldstraße 19
D-81673 München
Germany

Telefon: (49) 89 45 49 49 0
Fax: (49) 89 45 49 49 49
europe.sales@zetex.com

Americas

Zetex Inc
700 Veterans Memorial Highway
Hauppauge, NY 11788
USA

Telephone: (1) 631 360 2222
Fax: (1) 631 360 8222
usa.sales@zetex.com

Asia Pacific

Zetex (Asia Ltd)
3701-04 Metroplaza Tower 1
Hing Fong Road, Kwai Fong
Hong Kong

Telephone: (852) 26100 611
Fax: (852) 24250 494
asia.sales@zetex.com

Corporate Headquarters

Zetex Semiconductors plc
Zetex Technology Park, Chadderton
Oldham, OL9 9LL
United Kingdom

Telephone (44) 161 622 4444
Fax: (44) 161 622 4446
hq@zetex.com

These offices are supported by agents and distributors in major countries world-wide.

This publication is issued to provide outline information only which (unless agreed by the company in writing) may not be used, applied or reproduced for any purpose or form part of any order or contact or be regarded as a representation relating to the products or services concerned. The company reserves the right to alter without notice the specification, design, price or conditions of supply of any product or service.