



Chipsmall Limited consists of a professional team with an average of over 10 year of expertise in the distribution of electronic components. Based in Hongkong, we have already established firm and mutual-benefit business relationships with customers from,Europe,America and south Asia,supplying obsolete and hard-to-find components to meet their specific needs.

With the principle of “Quality Parts,Customers Priority,Honest Operation,and Considerate Service”,our business mainly focus on the distribution of electronic components. Line cards we deal with include Microchip,ALPS,ROHM,Xilinx,Pulse,ON,Everlight and Freescale. Main products comprise IC,Modules,Potentiometer,IC Socket,Relay,Connector.Our parts cover such applications as commercial,industrial, and automotives areas.

We are looking forward to setting up business relationship with you and hope to provide you with the best service and solution. Let us make a better world for our industry!



## Contact us

Tel: +86-755-8981 8866 Fax: +86-755-8427 6832

Email & Skype: info@chipsmall.com Web: www.chipsmall.com

Address: A1208, Overseas Decoration Building, #122 Zhenhua RD., Futian, Shenzhen, China



**ZXRE4041**  
**SOT23 MICROPOWER 1.225V VOLTAGE REFERENCE**

**Description**

The ZXRE4041 is a bandgap circuit designed to achieve a precision micropower voltage reference of 1.225 volts. The device is available in the small outline SOT23 surface mount package which is ideal for applications where space saving is important.

SOT23 tolerance is available to 0.5% C grade for precision applications. Excellent performance is maintained over the 30 A to 12mA operating current range with a typical temperature coefficient of only 20ppm/°C. The device has been designed to be highly tolerant of capacitive loads so maintaining excellent stability.

This device offers a SOT23 pin for pin compatible alternative to LM4041 voltage references.

**Features**

- High performance alternative to LM4041
- Small outline SOT23
- 30µA knee current
- 20ppm/°C typical temperature coefficient
- Unconditionally stable
- 0.5%, 1%, and 2% tolerance
- Green molding compound (No Br, Sb)

**Applications**

- Battery powered equipment
- Precision power supplies
- Portable instrumentation
- Portable communication devices
- Notebook and palm top computers
- Data acquisition systems
- A/D and D/A converters
- Test equipment

**Pin Assignments**

SOT23 Package Suffix - F

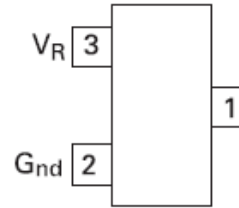

(Top view)

Pin 1 floating or connected to pin 2

**Schematic Diagram**

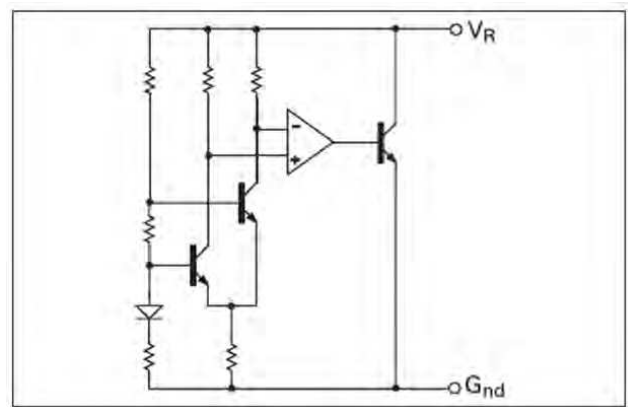

**Application Circuit**

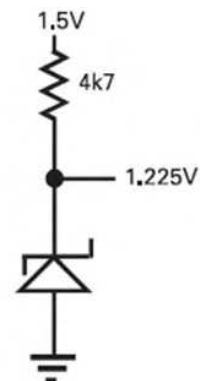

**Absolute Maximum Ratings** (Voltages to GND Unless Otherwise Stated)

Parameter	Symbol	Rating	Unit
Reverse Current	$V_Z$	30	mA
Forward Current		10	mA
Operating Temperature	$T_{OMP}$	-40 to 125	°C
Storage Temperature	$T_{STG}$	-55 to 125	°C
Power Dissipation ( $T_{AMB} = 25^{\circ}C$ )	$P_D$	330	mW

**Electrical Characteristics** (Test conditions:  $T_{amb} = 25^{\circ}C$ , unless otherwise specified.)

Symbol	Parameter	Condition	Min.	Typ.	Max.	Tol. (%)	Unit
$V_R$	Reverse breakdown voltage	$I_R = 100\mu A$	1.219 1.213	1.225 1.225	1.231 1.237	C/0.5 D/1	V
$I_{MIN}$	Minimum operating current				30		$\mu A$
$I_R$	Recommended operating current		0.03		12		mA
$T_C^{(*)}$	Average reverse breakdown voltage temperature coefficient	$I_{R(min)}$ to $I_{R(max)}$		20	100		ppm/°C
$R_S^{(†)}$	Reverse Breakdown Change with Current Voltage	$I_R = 30\mu A$ to $1\mu A$ $I_R = 1mA$ to $12mA$			1 10		mV
$Z_R$	Reverse dynamic impedance	$I_R = 1mA$ $f = 100Hz$ $I_{AC} = 0.1I_R$		0.2	0.6		$\Omega$
$E_N$	Wideband noise voltage	$I_R = 8\mu A$ to $100\mu A$ $f = 10Hz$ to $10kHz$		60			$\mu V(rms)$

Notes:

$$(*) T_C = \frac{(V_{R(MAX)} - V_{R(MIN)}) \times 1000000}{V_R \times (T_{(MAX)} - T_{(MIN)})}$$

Note:  $V_{R(MAX)} - V_{R(MIN)}$  is the maximum deviation in reference voltage measured over the full operating temperature range.

$$(†) R_S = \frac{\Delta V_R}{\Delta I_R}$$

**REVERSE CHARACTERISTICS**

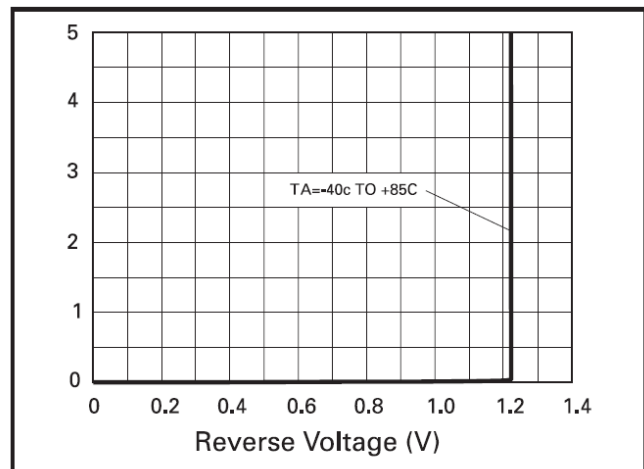



**Typical Characteristics**

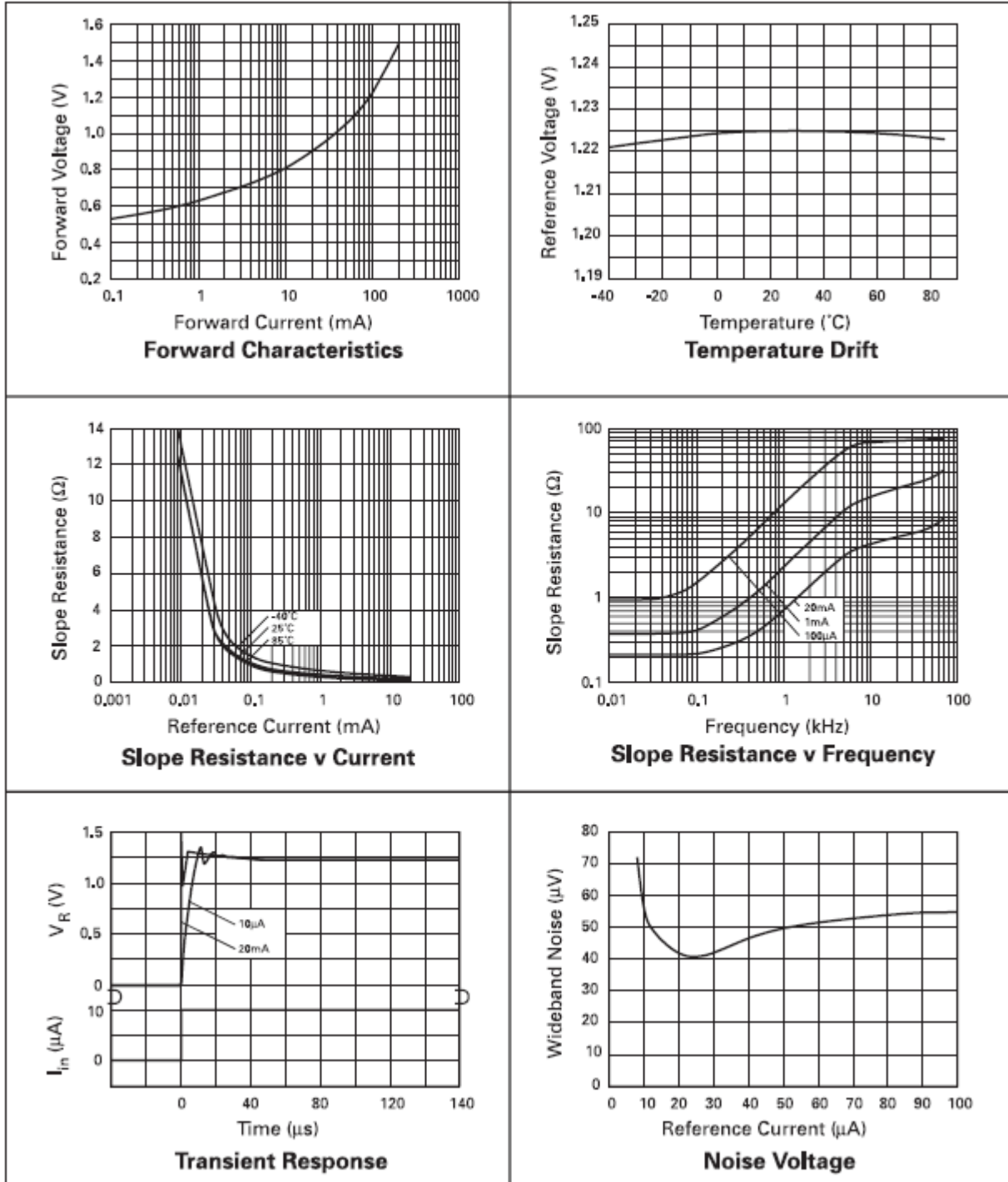

**Ordering Information\***

Order Reference	Tol (%)	Device Mark	Grade	Status (*)	Reel Size (inches)	Quantity per reel	Tape Width (mm)
ZXRE4041CF	0.5	10J	C	Released	7	3000	8
ZXRE4041DF	1	10H	D	Released	7	3000	8

Notes: \*All E-LINE variants of ZXRE4041 are obsolete and no longer available for sale. The closet alternative is the SOT23

**Package Outline SOT23**

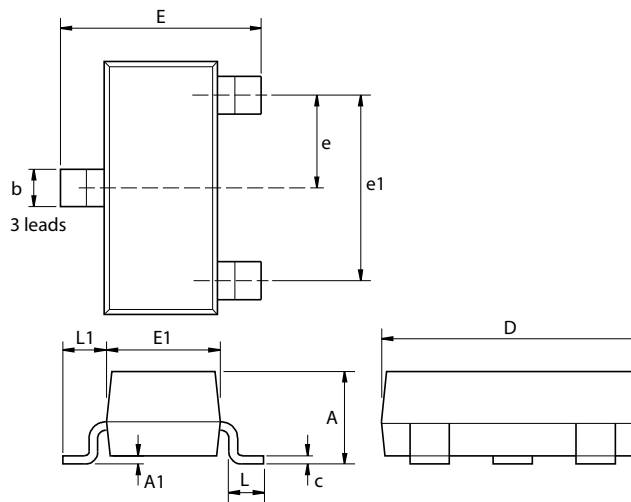

Dim.	Millimeters		Inches		Dim.	Millimeters		Inches	
	Min.	Max.	Min.	Max.		Min.	Max.	Min.	Max.
A	-	1.12	-	0.044	e1	1.90 NOM		0.075 NOM	
A1	0.01	0.10	0.0004	0.004	E	2.10	2.64	0.083	0.104
b	0.30	0.50	0.012	0.020	E1	1.20	1.40	0.047	0.055
c	0.085	0.20	0.003	0.008	L	0.25	0.60	0.0098	0.0236
D	2.80	3.04	0.110	0.120	L1	0.45	0.62	0.018	0.024
e	0.95 NOM		0.037 NOM		-	-	-	-	-

**Note:** Controlling dimensions are in millimeters. Approximate dimensions are provided in inches

#### IMPORTANT NOTICE

DIODES INCORPORATED MAKES NO WARRANTY OF ANY KIND, EXPRESS OR IMPLIED, WITH REGARDS TO THIS DOCUMENT, INCLUDING, BUT NOT LIMITED TO, THE IMPLIED WARRANTIES OF MERCHANTABILITY AND FITNESS FOR A PARTICULAR PURPOSE (AND THEIR EQUIVALENTS UNDER THE LAWS OF ANY JURISDICTION).

Diodes Incorporated and its subsidiaries reserve the right to make modifications, enhancements, improvements, corrections or other changes without further notice to this document and any product described herein. Diodes Incorporated does not assume any liability arising out of the application or use of this document or any product described herein; neither does Diodes Incorporated convey any license under its patent or trademark rights, nor the rights of others. Any Customer or user of this document or products described herein in such applications shall assume all risks of such use and will agree to hold Diodes Incorporated and all the companies whose products are represented on Diodes Incorporated website, harmless against all damages.

Diodes Incorporated does not warrant or accept any liability whatsoever in respect of any products purchased through unauthorized sales channel.

Should Customers purchase or use Diodes Incorporated products for any unintended or unauthorized application, Customers shall indemnify and hold Diodes Incorporated and its representatives harmless against all claims, damages, expenses, and attorney fees arising out of, directly or indirectly, any claim of personal injury or death associated with such unintended or unauthorized application.

Products described herein may be covered by one or more United States, international or foreign patents pending. Product names and markings noted herein may also be covered by one or more United States, international or foreign trademarks.

#### LIFE SUPPORT

Diodes Incorporated products are specifically not authorized for use as critical components in life support devices or systems without the express written approval of the Chief Executive Officer of Diodes Incorporated. As used herein:

A. Life support devices or systems are devices or systems which:

1. are intended to implant into the body, or
2. support or sustain life and whose failure to perform when properly used in accordance with instructions for use provided in the labeling can be reasonably expected to result in significant injury to the user.

B. A critical component is any component in a life support device or system whose failure to perform can be reasonably expected to cause the failure of the life support device or to affect its safety or effectiveness.

Customers represent that they have all necessary expertise in the safety and regulatory ramifications of their life support devices or systems, and acknowledge and agree that they are solely responsible for all legal, regulatory and safety-related requirements concerning their products and any use of Diodes Incorporated products in such safety-critical, life support devices or systems, notwithstanding any devices- or systems-related information or support that may be provided by Diodes Incorporated. Further, Customers must fully indemnify Diodes Incorporated and its representatives against any damages arising out of the use of Diodes Incorporated products in such safety-critical, life support devices or systems.

Copyright © 2010, Diodes Incorporated

[www.diodes.com](http://www.diodes.com)